

HEATING AND AIR CONDITIONING

TABLE OF CONTENTS

	page		page
DESCRIPTION AND OPERATION			
BLOWER MOTOR	2	DUAL FUNCTION HIGH PRESSURE SWITCH/HIGH PRESSURE CUT-OFF SWITCH	22
BLOWER MOTOR RELAY	2	LOW PRESSURE CUT-OFF SWITCH	22
BLOWER MOTOR RESISTOR	3	REFRIGERANT SYSTEM LEAKS	23
BLOWER MOTOR SWITCH	4	REFRIGERANT SYSTEM SERVICE EQUIPMENT	24
COMPRESSOR	4	VACUUM SYSTEM	24
COMPRESSOR CLUTCH	4	SERVICE PROCEDURES	
COMPRESSOR CLUTCH RELAY	5	REFRIGERANT OIL LEVEL	28
CONDENSER	5	REFRIGERANT RECOVERY	28
ELECTRONIC CYCLING CLUTCH SWITCH	5	REFRIGERANT SYSTEM CHARGE	28
EVAPORATOR COIL	6	REFRIGERANT SYSTEM EVACUATE	28
EXPANSION VALVE	6	REMOVAL AND INSTALLATION	
FILTER-DRIER	6	SERVICE WARNINGS AND PRECAUTIONS	29
HEATER AND AIR CONDITIONER	7	B-PILLAR REFRIGERANT LINE	31
HEATER AND AIR CONDITIONER CONTROL	8	BLOWER MOTOR	32
HEATER CORE	8	BLOWER MOTOR RELAY	34
HIGH PRESSURE CUT-OFF SWITCH	8	BLOWER MOTOR RESISTOR	35
HIGH PRESSURE RELIEF VALVE	8	COMPRESSOR	37
LOW PRESSURE CUT-OFF SWITCH	9	COMPRESSOR CLUTCH	38
REAR OVERHEAD AIR CONDITIONER	9	COMPRESSOR CLUTCH RELAY	41
REFRIGERANT	9	CONDENSER	41
REFRIGERANT LINES	9	DUCTS AND OUTLETS	43
REFRIGERANT LINE COUPLERS	10	ELECTRONIC CYCLING CLUTCH SWITCH	48
REFRIGERANT OIL	10	EVAPORATOR COIL	48
REFRIGERANT SYSTEM SERVICE PORTS	11	EXPANSION VALVE	51
VACUUM CHECK VALVE	11	FILTER-DRIER	52
VACUUM RESERVOIR	11	HEATER-A/C CONTROL	53
DIAGNOSIS AND TESTING			
A/C PERFORMANCE	11	HEATER-A/C HOUSING	54
BLOWER MOTOR	15	HEATER-A/C HOUSING DOOR	57
BLOWER MOTOR RELAY	15	HEATER CORE	59
BLOWER MOTOR RESISTOR	16	HIGH PRESSURE CUT-OFF SWITCH	59
BLOWER MOTOR SWITCH	17	LIQUID LINE	60
COMPRESSOR	17	LOW PRESSURE CUT-OFF SWITCH	62
COMPRESSOR CLUTCH COIL	18	MODE DOOR VACUUM ACTUATOR	62
COMPRESSOR CLUTCH RELAY	18	REAR BLOWER MOTOR SWITCH	63
ELECTRONIC CYCLING CLUTCH SWITCH (Front Unit Only)	19	REAR OVERHEAD A/C UNIT	64
EXPANSION VALVE	19	REFRIGERANT LINE COUPLER	66
HEATER-A/C CONTROL	20	SUCTION AND DISCHARGE LINE	66
HEATER PERFORMANCE	21	SUCTION LINE JUMPER	67
		TEMPERATURE CONTROL CABLE	68

UNDERBODY REFRIGERANT LINE..... 69
 VACUUM CHECK VALVE..... 70
 VACUUM RESERVOIR 70

ADJUSTMENTS

TEMPERATURE CONTROL CABLE 72

DESCRIPTION AND OPERATION

BLOWER MOTOR

FRONT

DESCRIPTION

The blower motor and blower wheel are located in the passenger side end of the heater-A/C housing, below the glove box. The blower motor controls the velocity of air flowing through the heater-A/C housing by spinning a squirrel cage-type blower wheel within the housing at the selected speed. The blower motor and blower wheel can only be serviced with the heater-A/C housing removed from the passenger compartment.

OPERATION

The blower motor will only operate when the ignition switch is in the On position, and the heater-A/C mode control switch knob is in any position, except Off. The blower motor receives a fused battery feed through the blower motor relay (Voltage Reduction Relay or VRR) whenever the ignition switch is in the On position.

The blower motor battery feed circuit is protected by a fuse in the Power Distribution Center (PDC). The blower motor relay control circuit is protected by a fuse in the junction block. Blower motor speed is controlled by regulating the ground path through the heater-A/C mode control switch, the blower motor switch, the blower motor resistor, the blower motor relay (VRR), and the high speed blower motor relay.

The blower motor and blower motor wheel cannot be repaired and, if faulty or damaged, they must be replaced. The blower motor and blower wheel are each serviced separately.

REAR

DESCRIPTION

The rear blower motor and blower wheel are mounted to a blower wheel housing located inside the rear overhead A/C unit, above the headliner. The blower motor controls the velocity of air flowing through the overhead A/C unit by spinning a wide squirrel cage-type blower wheel within the housing at the selected speed. Rear blower motor speed is controlled by regulating the ground path through the

SPECIFICATIONS

A/C APPLICATION TABLE..... 73

rear blower motor switch and the rear blower motor resistor.

OPERATION

The rear blower motor will only operate when the ignition switch is in the On position. The rear blower motor receives a fused battery feed through a fuse in the relay and fuse block whenever the ignition switch is in the On position. The relay and fuse block is attached to the back of the junction block, under the left side of the instrument panel in the passenger compartment.

The rear blower motor, blower wheel, and blower wheel housing cannot be repaired and, if faulty or damaged, they must be replaced as a complete factory-balanced unit.

BLOWER MOTOR RELAY

DESCRIPTION

The blower motor relay (also referred to as Voltage Reduction Relay or VRR) is an International Standards Organization (ISO)-type relay. The relay is an electromechanical device that switches battery current from a fuse in the Power Distribution Center (PDC) directly to the blower motor. The relay is energized when the relay coil is provided a voltage signal by the ignition switch. This arrangement reduces the amount of battery current that must flow through the ignition switch.

OPERATION

The blower motor relay control circuit is protected by a fuse located in the junction block. When the relay is de-energized, the blower motor receives no battery current. The VRR is used to reduce blower speeds in Heat mode. In non-A/C modes, the relay is de-energized and switches the current flow through an added resistance in the resistor block. When an A/C mode is selected, the relay is energized and the normally open contact is used to bypass the added resistor. The fuse is located in the small relay fuse block that is attached to the Junction Block. The relay is energized by grounding the coil low side with the HVAC switch in any A/C mode. See Blower Motor Relay in the Diagnosis and Testing section of this group for more information.

The blower motor relay is mounted with a single screw directly to the instrument panel's structural

DESCRIPTION AND OPERATION (Continued)

plastic inside the glove box opening, next to the left-side energy-absorbing bracket (Fig. 1). Refer to the PDC label for blower motor relay identification and location.

The blower motor relay (VRR) cannot be repaired and, if faulty or damaged, it must be replaced.

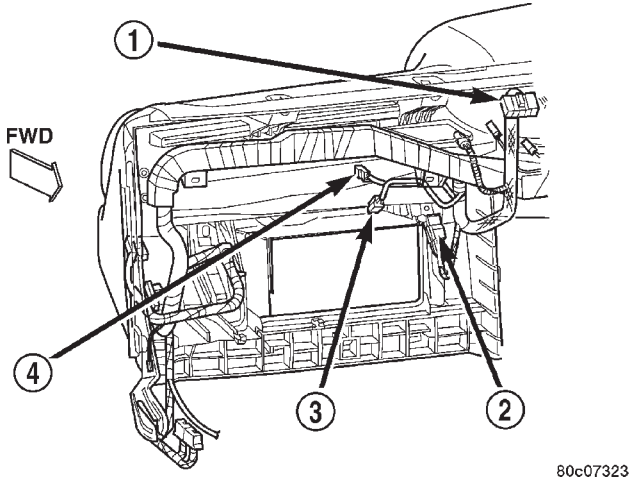

Fig. 1 Blower Motor Relay (VRR) Location

- 1 - BLOWER MOTOR RESISTOR CONNECTOR
- 2 - BLOWER MOTOR RELAY
- 3 - BLOWER MOTOR CONNECTOR
- 4 - GLOVE BOX LAMP CONNECTOR

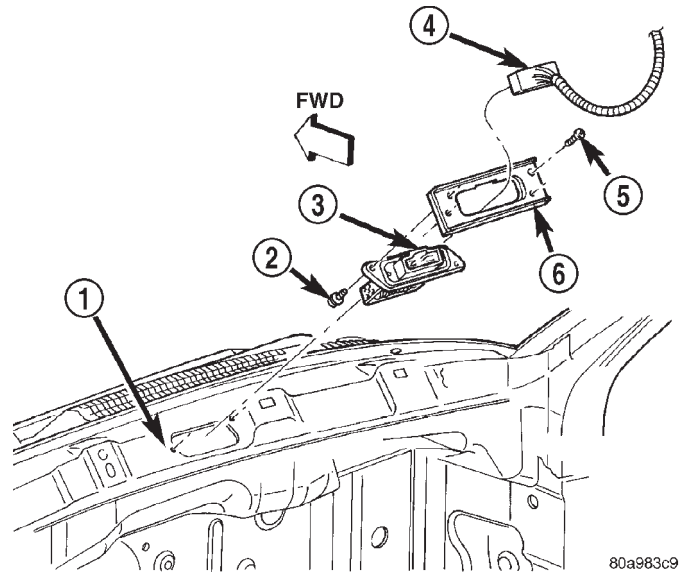

Fig. 2 Blower Motor Resistor - Factory Installation

- 1 - PLENUM PANEL
- 2 - SCREW
- 3 - RESISTOR
- 4 - CONNECTOR
- 5 - SCREW
- 6 - RESISTOR MOUNTING PLATE

BLOWER MOTOR RESISTOR

FRONT

DESCRIPTION

During vehicle assembly, the blower motor resistor is mounted to the dash plenum panel inside the passenger compartment prior to instrument panel roll-up (Fig. 2). However, a resistor mounting plate has been designed so that the resistor can be removed through an access hole in the cowl plenum panel just below the windshield. It can be accessed by removing the cowl plenum cover/grille panel. See Blower Motor Resistor in the Removal and Installation section of this group for more information.

OPERATION

The resistor has multiple resistor wires, each of which will change the resistance in the blower motor ground path to change the blower motor speed. The blower motor switch directs the ground path through the correct resistor wire to obtain the selected blower motor speed.

With the blower motor switch in the lowest speed position, the ground path for the motor is applied through all of the resistor wires. Each higher speed selected with the blower motor switch applies the blower motor ground path through fewer of the resis-

tor wires, increasing the blower motor speed. When the blower motor switch is in the highest speed position, the blower motor resistor is bypassed and the blower motor receives a direct path to ground through the high speed blower motor relay.

The blower motor resistor cannot be repaired and, if faulty or damaged, it must be replaced.

REAR

DESCRIPTION

The blower motor resistor for the optional rear overhead A/C unit is located within the unit housing. The resistor has multiple resistor wires, each of which will change the resistance in the blower motor ground path to change the blower motor speed. The blower motor switch directs the ground path through the correct resistor wire to obtain the selected blower motor speed.

OPERATION

With the blower motor switch in the lowest speed position, the ground path for the motor is applied through all of the resistor wires. Each higher speed selected with the blower motor switch applies the blower motor ground path through fewer of the resistor wires, increasing the blower motor speed. When the blower motor switch is in the highest speed position, the blower motor resistor is bypassed and the blower motor receives a direct path to ground.

DESCRIPTION AND OPERATION (Continued)

The blower motor resistor cannot be repaired and, if faulty or damaged, it must be replaced.

BLOWER MOTOR SWITCH**FRONT****DESCRIPTION**

The heater-A/C blower motor is controlled by a four position rotary-type blower motor switch, mounted in the heater-A/C control panel. The switch allows the selection of one of four blower motor speeds, but can only be turned off by selecting the Off position with the heater-A/C mode control switch knob.

OPERATION

The blower motor switch directs the blower motor ground path through the mode control switch to the blower motor resistor, or directly to ground through the high speed blower motor relay, as required to achieve the selected blower motor speed.

The blower motor switch cannot be repaired and, if faulty or damaged, the entire heater-A/C control unit must be replaced. The blower motor switch knob is serviced separately.

REAR**DESCRIPTION**

The optional rear overhead A/C unit blower motor is controlled by a four position rotary-type blower motor switch, mounted by a snap fit in a hole in the headliner over the right front seat back. The switch allows the selection of one of three blower motor speeds and an Off position. The blower motor switch directs the blower motor ground path through the blower motor resistor.

OPERATION

The blower motor switch cannot be repaired and, if faulty or damaged, the entire switch unit must be replaced. The blower motor switch has a replaceable incandescent-type illumination lamp bulb.

COMPRESSOR**DESCRIPTION**

The air conditioning system uses a Sanden SD7H15 seven cylinder, reciprocating wobble plate-type compressor on all models. This compressor has a fixed displacement of 150 cubic centimeters (9.375 cubic inches), and has both the suction and discharge ports located on the cylinder head. A label identifying the use of R-134a refrigerant is located on the compressor.

OPERATION

The compressor is driven by the engine through an electric clutch, drive pulley and belt arrangement. The compressor is lubricated by refrigerant oil that is circulated throughout the refrigerant system with the refrigerant.

The compressor draws in low-pressure refrigerant vapor from the evaporator through its suction port. It then compresses the refrigerant into a high-pressure, high-temperature refrigerant vapor, which is then pumped to the condenser through the compressor discharge port.

The compressor cannot be repaired. If faulty or damaged, the entire compressor assembly must be replaced. The compressor clutch, pulley and clutch coil are available for service.

COMPRESSOR CLUTCH**DESCRIPTION**

The compressor clutch assembly consists of a stationary electromagnetic coil, a hub bearing and pulley assembly, and a clutch plate (Fig. 3). The electromagnetic coil unit and the hub bearing and pulley assembly are each retained on the nose of the compressor front housing with snap rings. The clutch plate is mounted to the compressor shaft and secured with a nut.

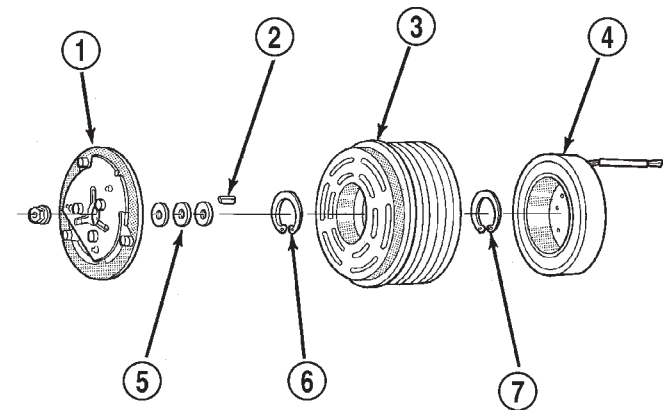

J9524-33

Fig. 3 Compressor Clutch - Typical

- 1 - CLUTCH PLATE
- 2 - SHAFT KEY
- 3 - PULLEY
- 4 - COIL
- 5 - CLUTCH SHIMS
- 6 - SNAP RING
- 7 - SNAP RING

OPERATION

These components provide the means to engage and disengage the compressor from the engine serpentine accessory drive belt. When the clutch coil is

DESCRIPTION AND OPERATION (Continued)

energized, it magnetically draws the clutch into contact with the pulley and drives the compressor shaft. When the coil is not energized, the pulley freewheels on the clutch hub bearing, which is part of the pulley. The compressor clutch and coil are the only serviced parts on the compressor.

The compressor clutch engagement is controlled by several components: the heater-A/C mode control switch, the electronic cycling clutch switch, the low pressure cut-off switch, the high pressure cut-off switch, the compressor clutch relay, and the Powertrain Control Module (PCM). The PCM may delay compressor clutch engagement for up to thirty seconds. Refer to Group 14 - Fuel System for more information on the PCM controls.

COMPRESSOR CLUTCH RELAY

DESCRIPTION

The compressor clutch relay is an International Standards Organization (ISO) micro-relay. The terminal designations and functions are the same as a conventional ISO relay. However, the micro-relay terminal orientation (footprint) is different, the current capacity is lower, and the relay case dimensions are smaller than those of the conventional ISO relay.

OPERATION

The compressor clutch relay is an electromechanical device that switches battery current to the compressor clutch coil when the Powertrain Control Module (PCM) grounds the coil side of the relay. The PCM responds to inputs from the heater-A/C mode control switch, the electronic cycling clutch switch, the low pressure cut-off switch, and the high pressure cut-off switch. See Compressor Clutch Relay in the Diagnosis and Testing section of this group for more information.

The compressor clutch relay is located in the Power Distribution Center (PDC) in the engine compartment. Refer to the PDC label for relay identification and location.

The compressor clutch relay cannot be repaired and, if faulty or damaged, it must be replaced.

CONDENSER

DESCRIPTION

The condenser is located in the air flow in front of the engine cooling radiator. The condenser is a heat exchanger that allows the high-pressure refrigerant gas being discharged by the compressor to give up its heat to the air passing over the condenser fins.

OPERATION

When the refrigerant gas gives up its heat, it condenses. When the refrigerant leaves the condenser, it has become a high-pressure liquid refrigerant. The volume of air flowing over the condenser fins is critical to the proper cooling performance of the air conditioning system. Therefore, it is important that there are no objects placed in front of the radiator grille openings in the front of the vehicle or foreign material on the condenser fins that might obstruct proper air flow. Also, any factory-installed air seals or shrouds must be properly reinstalled following radiator or condenser service.

The condenser cannot be repaired and, if faulty or damaged, it must be replaced.

ELECTRONIC CYCLING CLUTCH SWITCH

DESCRIPTION

The Electronic Cycling Clutch Switch (ECCS) is mounted to the outboard side of the thermal expansion valve in the engine compartment. A thermistor probe within a capillary tube on the switch is inserted into a well on the side of the expansion valve filled with a thermally-conductive grease. This arrangement allows the ECCS to monitor the temperature of the expanded refrigerant entering the evaporator.

OPERATION

The function of the ECCS is to prevent refrigerant temperatures from becoming so low that condensation freezes on the evaporator fins. This condition is referred to as evaporator icing. Evaporator icing reduces air conditioning system air flow and cooling performance.

The ECCS is connected in series electrically with the heater-A/C mode control switch, the low pressure cut-off switch and the high pressure cut-off switch between ground and the Powertrain Control Module (PCM). The ECCS will open when it monitors a refrigerant temperature below about 2.9° C (37.2° F), and will close again when the refrigerant temperature reaches about 4.3° C (39.7° F). The opening and closing of the ECCS signals the PCM to cycle the compressor clutch on and off through the compressor clutch relay.

The ECCS is a factory sealed and calibrated unit and cannot be adjusted or repaired. If faulty or damaged, the ECCS must be replaced.

DESCRIPTION AND OPERATION (Continued)

EVAPORATOR COIL**FRONT****DESCRIPTION**

The evaporator coil is located in the heater-A/C housing, under the instrument panel. The evaporator coil is positioned in the heater-A/C housing so that all air that enters the housing must pass over the fins of the evaporator before it is distributed through the system ducts and outlets. However, air passing over the evaporator coil fins will only be conditioned when the compressor is engaged and circulating refrigerant through the evaporator coil tubes.

OPERATION

Refrigerant enters the evaporator from the expansion valve as a low-temperature, low-pressure mixture of liquid and gas. As air flows over the fins of the evaporator, the humidity in the air condenses on the fins, and the heat from the air is absorbed by the refrigerant. Heat absorption causes the refrigerant to boil and vaporize. The refrigerant becomes a low-pressure gas when it leaves the evaporator.

The evaporator coil cannot be repaired and, if faulty or damaged, it must be replaced.

REAR**DESCRIPTION**

The rear evaporator coil is located in the rear overhead A/C unit housing, above the headliner. The evaporator coil is positioned in the overhead A/C unit housing so that all air that enters the housing must pass over the fins of the evaporator before it is distributed through the system outlets. However, air passing over the evaporator coil fins will only be conditioned when the compressor is engaged and circulating refrigerant through the evaporator coil tubes.

OPERATION

Refrigerant enters the evaporator from the rear expansion valve as a low-temperature, low-pressure mixture of liquid and gas. As air flows over the fins of the evaporator, the humidity in the air condenses on the fins, and the heat from the air is absorbed by the refrigerant. Heat absorption causes the refrigerant to boil and vaporize. The refrigerant becomes a low-pressure gas when it leaves the evaporator.

The rear evaporator coil cannot be repaired and, if faulty or damaged, the rear evaporator coil must be replaced.

EXPANSION VALVE**FRONT****DESCRIPTION**

The front "H" valve-type thermal expansion valve (TXV) is located at the dash panel between the liquid and suction lines, and the evaporator coil. High-pressure, high temperature liquid refrigerant from the liquid line passes through the expansion valve orifice, converting it into a low-pressure, low-temperature mixture of liquid and gas before it enters the evaporator coil.

OPERATION

A sensor in the expansion valve control head monitors the temperature and pressure of the refrigerant leaving the evaporator coil through the suction line, and adjusts the orifice size at the liquid line to let the proper amount of refrigerant into the evaporator coil to meet the vehicle cooling requirements. Controlling the refrigerant flow through the evaporator ensures that none of the refrigerant leaving the evaporator is still in a liquid state, which could damage the compressor.

The expansion valve is a factory calibrated unit and cannot be adjusted or repaired. If faulty or damaged, the expansion valve must be replaced.

REAR**DESCRIPTION**

Vehicles equipped with the optional rear overhead A/C unit have an H-type thermal expansion valve (TXV) located underneath the passenger side of the vehicle floor panel, next to the sill. It performs the same function as the front expansion valve, to monitor refrigerant temperature and pressure at the control head and meter the refrigerant entering the evaporator to meet the vehicle cooling requirements.

OPERATION

The rear expansion valve is a factory calibrated unit and cannot be adjusted or repaired. If faulty or damaged, the rear expansion valve unit must be replaced.

FILTER-DRIER**DESCRIPTION**

The filter-drier is mounted on the right front wheelhouse front extension in the engine compartment, in the liquid line between the condenser outlet and the evaporator inlet. Refrigerant enters the filter-drier as a high-pressure, high-temperature liquid.

DESCRIPTION AND OPERATION (Continued)

OPERATION

The filter-drier performs a filtering action to prevent foreign material in the refrigerant from contaminating the expansion valve. A desiccant bag is mounted inside the filter-drier canister to absorb any moisture which may have entered and become trapped within the refrigerant system. In addition, during periods of high demand air conditioner operation, the filter-drier acts as a reservoir to store surplus refrigerant.

The filter-drier cannot be repaired. If the filter-drier is faulty or damaged, or if the refrigerant system has been contaminated or left open to the atmosphere for an indeterminable period, it must be replaced.

HEATER AND AIR CONDITIONER

DESCRIPTION

All vehicles are equipped with a common heater-A/C housing assembly (Fig. 4). The system combines air conditioning, heating, and ventilating capabilities in a single unit housing mounted under the instrument panel.

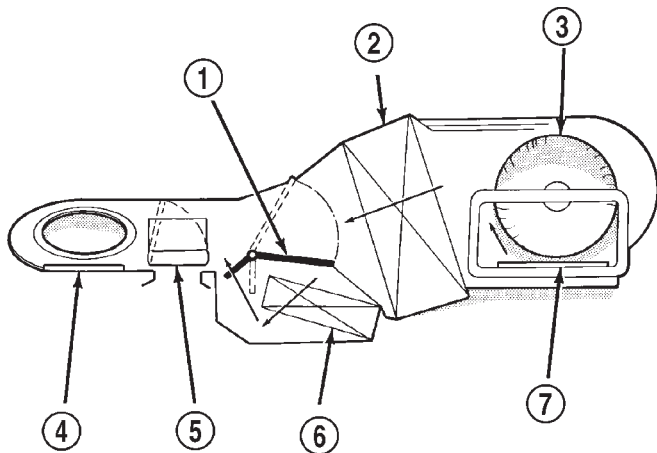

J9324-3

Fig. 4 Common Blend-Air Heater-Air Conditioner System - Typical

- 1 - TEMPERATURE BLEND/AIR DOOR
- 2 - EVAPORATOR CORE
- 3 - BLOWER
- 4 - PANEL DEFROST DOOR
- 5 - HEAT DEFROST DOOR
- 6 - HEATER CORE
- 7 - RECIRCULATING AIR DOOR

OPERATION

Outside fresh air enters the vehicle through the cowl top opening at the base of the windshield, and passes through a plenum chamber to the heater-A/C system blower housing. Air flow velocity can then be adjusted with the blower motor speed selector switch

on the heater-A/C control panel. The air intake openings must be kept free of snow, ice, leaves, and other obstructions for the heater-A/C system to receive a sufficient volume of outside air.

It is also important to keep the air intake openings clear of debris because leaf particles and other debris that is small enough to pass through the cowl plenum screen can accumulate within the heater-A/C housing. The closed, warm, damp and dark environment created within the heater-A/C housing is ideal for the growth of certain molds, mildews and other fungi. Any accumulation of decaying plant matter provides an additional food source for fungal spores, which enter the housing with the fresh air. Excess debris, as well as objectionable odors created by decaying plant matter and growing fungi can be discharged into the passenger compartment during heater-A/C system operation.

The heater and air conditioner are blend-air type systems. In a blend-air system, a blend-air door controls the amount of unconditioned air or cooled air from the evaporator that is allowed to flow through, or around, the heater core. A temperature control knob on the heater-A/C control panel determines the discharge air temperature by moving a cable, which operates the blend-air door. This allows an almost immediate manual control of the output air temperature of the system.

The mode control knob on the heater-A/C control panel is used to direct the conditioned air to the selected system outlets. The mode control switch uses engine vacuum to control the mode doors, which are operated by vacuum actuator motors.

The outside air intake can be shut off by selecting the recirculation mode (Max A/C) with the mode control knob. This will operate a vacuum actuated recirculating air door that closes off the outside fresh air intake and recirculates the air that is already inside the vehicle.

A large central duct delivers conditioned air from the front heater-A/C housing to the second and third seat floor panel foot wells. A damper door in this duct can be adjusted by the second seat passengers with a manual control located on a mini-console just behind the split bench seat center cushion, or located on the upper rear surface of the floor console on models with the optional bucket seats. The split bench seat control has two positions: On or Off. The bucket seat control has three positions: On, Off and a third position that directs air flow through a pair of adjustable barrel outlets mounted high on the rear surface of the floor console.

The air conditioner for all models is designed for the use of non-CFC, R-134a refrigerant. The air conditioning system has an evaporator to cool and dehumidify the incoming air prior to blending it with the

DESCRIPTION AND OPERATION (Continued)

heated air. This air conditioning system uses a thermal expansion valve between the condenser and the evaporator coil to meter refrigerant flow to the evaporator coil. To maintain minimum evaporator temperature and prevent evaporator freezing, an electronic cycling clutch switch on the expansion valve cycles the compressor clutch.

HEATER AND AIR CONDITIONER CONTROL

DESCRIPTION

The heater and A/C system use a combination of mechanical, electrical, and vacuum controls. These controls provide the vehicle operator with a number of setting options to help control the climate and comfort within the vehicle. Refer to the owner's manual in the vehicle glove box for more information on the features, use, and suggested operation of these controls.

OPERATION

The heater-A/C control panel is located to the right of the instrument cluster on the instrument panel. The control panel contains a rotary-type temperature control knob, a rotary-type mode control switch knob, and a rotary-type blower motor speed switch knob.

The heater-A/C control panel cannot be repaired. If faulty or damaged, the entire unit must be replaced. The illumination lamps are available for service replacement.

HEATER CORE

DESCRIPTION

The heater core is located in the heater-A/C housing, under the instrument panel. It is a heat exchanger made of rows of tubes and fins.

OPERATION

Engine coolant is circulated through heater hoses to the heater core at all times. As the coolant flows through the heater core, heat removed from the engine is transferred to the heater core fins and tubes. Air directed through the heater core picks up the heat from the heater core fins. The blend air door allows control of the heater output air temperature by controlling how much of the air flowing through the heater-A/C housing is directed through the heater core. The blower motor speed controls the volume of air flowing through the heater-A/C housing.

The heater core cannot be repaired and, if faulty or damaged, it must be replaced. Refer to Cooling System for more information on the engine cooling system, the engine coolant and the heater hoses.

HIGH PRESSURE CUT-OFF SWITCH

DESCRIPTION

The high pressure cut-off switch is located on the discharge line near the compressor. The switch is screwed onto a fitting that contains a Schrader-type valve, which allows the switch to be serviced without discharging the refrigerant system. The discharge line fitting is equipped with an O-ring to seal the switch connection.

OPERATION

The high pressure cut-off switch is connected in series electrically with the electronic cycling clutch switch, the low pressure cut-off switch, and the Heater-A/C controls between ground and the Powertrain Control Module (PCM). The switch contacts open and close causing the PCM to turn the compressor clutch on and off. This prevents compressor operation when the discharge line pressure approaches high levels.

The high pressure cut-off switch contacts will open when the discharge line pressure rises above about 3100 to 3375 kPa (450 to 490 psi). The switch contacts will close when the discharge line pressure drops to about 1860 to 2275 kPa (270 to 330 psi).

The high pressure cut-off switch is a factory-calibrated unit. The switch cannot be adjusted or repaired and, if faulty or damaged, it must be replaced.

HIGH PRESSURE RELIEF VALVE

DESCRIPTION

A high pressure relief valve is located on the compressor cylinder head, which is at the rear of the compressor. This mechanical valve is designed to vent refrigerant from the system to protect against damage to the compressor and other system components, caused by condenser air flow restriction or an overcharge of refrigerant.

OPERATION

The high pressure relief valve vents the system when a discharge pressure of 3445 to 4135 kPa (500 to 600 psi) or above is reached. The valve closes with a minimum discharge pressure of 2756 kPa (400 psi) is reached.

The high pressure relief valve vents only enough refrigerant to reduce the system pressure, and then re-seats itself. The majority of the refrigerant is conserved in the system. If the valve vents refrigerant, it does not mean the valve is faulty.

The high pressure relief valve is a factory-calibrated unit. The valve cannot be adjusted or repaired, and must not be removed or otherwise dis-

DESCRIPTION AND OPERATION (Continued)

turbed. The valve is only serviced as a part of the compressor assembly.

LOW PRESSURE CUT-OFF SWITCH**DESCRIPTION**

The low pressure cut-off switch is located on the suction line jumper tube. The switch is screwed onto a fitting that contains a Schrader-type valve, which allows the switch to be serviced without discharging the refrigerant system. The fitting is equipped with an O-ring to seal the switch connection.

OPERATION

The low pressure cut-off switch is connected in series electrically with the high pressure cut-off switch, the heater-A/C controls, the Electronic Cycling Clutch Switch (ECCS), between ground, and the Powertrain Control Module (PCM). The switch contacts open and close causing the PCM to turn the compressor clutch on and off. This regulates the refrigerant system pressure, ensuring a sufficient amount of refrigerant throughout the system.

The low pressure cut-off switch contacts will open when the suction pressure is about 48 to 90 kPa (7 to 13 psi) or lower. The switch contacts will close when the suction pressure rises to about 103 to 193 kPa (15 to 28 psi) or above. Lower ambient temperatures, below about -1° C (30° F), will also cause the switch contacts to open. This is due to the pressure/temperature relationship of the refrigerant in the system.

The low pressure cut-off switch is a factory-calibrated unit. It cannot be adjusted or repaired and, if faulty or damaged, it must be replaced.

REAR OVERHEAD AIR CONDITIONER**DESCRIPTION**

A rear overhead air conditioning unit is an available option to supplement the output of the front air conditioner, for increased rear seat passenger comfort. This unit includes a roof-mounted evaporator coil and a blower motor with a wide squirrel-cage type blower wheel. A four position (three speeds plus off) rear blower motor switch is mounted in the headliner behind the right front seat position, where it is accessible to both the driver and the second seat passengers.

OPERATION

The wide and shallow rear unit is positioned between the front and second seats to provide ample headroom for all vehicle occupants. The headliner is molded to cover the unit and includes an integral air intake grille toward the front of the unit, and an opening for a snap-in outlet bezel that includes four

adjustable outlet barrels toward the rear of the unit. A condensate tray is integral to the lower unit housing, and water is drained out of the unit through hoses located behind the trim on each of the B-pillars.

The rear overhead air conditioner will provide cooling only when an air conditioning mode is selected with the front heater and A/C controls, but the rear blower will operate independent of the front controls to circulate the interior air if desired.

REFRIGERANT**DESCRIPTION**

The refrigerant used in this air conditioning system is a HydroFluoroCarbon (HFC), type R-134a. Unlike R-12, which is a ChloroFluoroCarbon (CFC), R-134a refrigerant does not contain ozone-depleting chlorine. R-134a refrigerant is a non-toxic, non-flammable, clear, and colorless liquefied gas.

Even though R-134a does not contain chlorine, it must be reclaimed and recycled just like CFC-type refrigerants. This is because R-134a is a greenhouse gas and can contribute to global warming.

OPERATION

R-134a refrigerant is not compatible with R-12 refrigerant in an air conditioning system. Even a small amount of R-12 added to an R-134a refrigerant system will cause compressor failure, refrigerant oil sludge or poor air conditioning system performance. In addition, the PolyAlkylene Glycol (PAG) synthetic refrigerant oils used in an R-134a refrigerant system are not compatible with the mineral-based refrigerant oils used in an R-12 refrigerant system.

R-134a refrigerant system service ports, service tool couplers and refrigerant dispensing bottles have all been designed with unique fittings to ensure that an R-134a system is not accidentally contaminated with the wrong refrigerant (R-12). There are also labels posted in the engine compartment of the vehicle and on the compressor identifying to service technicians that the air conditioning system is equipped with R-134a.

REFRIGERANT LINES**DESCRIPTION**

The refrigerant lines and hoses are used to carry the refrigerant between the various air conditioning system components. A barrier hose design with a nylon tube, which is sandwiched between rubber layers, is used for the R-134a air conditioning system on this vehicle. This nylon tube helps to further contain the R-134a refrigerant, which has a smaller molecular structure than R-12 refrigerant. The ends of the

DESCRIPTION AND OPERATION (Continued)

refrigerant hoses are made from lightweight aluminum or steel, and commonly use braze-less fittings.

Any kinks or sharp bends in the refrigerant plumbing will reduce the capacity of the entire air conditioning system. Kinks and sharp bends reduce the flow of refrigerant in the system. A good rule for the flexible hose refrigerant lines is to keep the radius of all bends at least ten times the diameter of the hose. In addition, the flexible hose refrigerant lines should be routed so they are at least 80 millimeters (3 inches) from the exhaust manifold.

OPERATION

High pressures are produced in the refrigerant system when the air conditioning compressor is operating. Extreme care must be exercised to make sure that each of the refrigerant system connections is pressure-tight and leak free. It is a good practice to inspect all flexible hose refrigerant lines at least once a year to make sure they are in good condition and properly routed.

The refrigerant lines and hoses are coupled with other components of the HVAC system with peanut-block style fittings. A stat-O seal type flat steel gasket with a captured compressible O-ring, and spring lock coupler, is used to mate plumbing lines with A/C components to ensure the integrity of the refrigerant system.

The refrigerant lines and hoses cannot be repaired and, if faulty or damaged, they must be replaced.

REFRIGERANT LINE COUPLERS

DESCRIPTION

Spring-lock type refrigerant line couplers are used to connect many of the refrigerant lines and other components to the refrigerant system. These couplers require a special tool for disengaging the two coupler halves.

OPERATION

The spring-lock coupler is held together by a garter spring inside a circular cage on the male half of the fitting (Fig. 5). When the two coupler halves are connected, the flared end of the female fitting slips behind the garter spring inside the cage on the male fitting. The garter spring and cage prevent the flared end of the female fitting from pulling out of the cage.

Two O-rings on the male half of the fitting are used to seal the connection. These O-rings are compatible with R-134a refrigerant and must be replaced with O-rings made of the same material.

Secondary clips are installed over the two connected coupler halves at the factory for added blowoff protection.

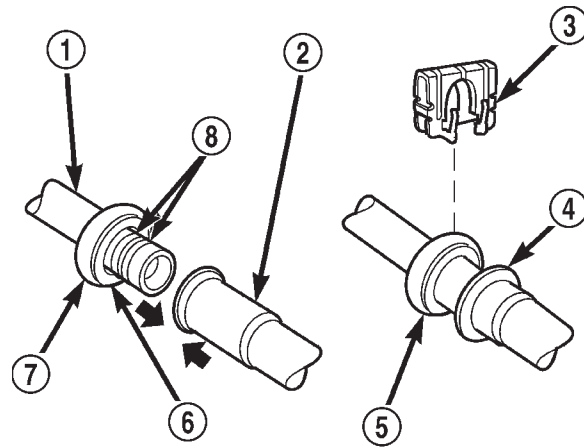

80a7e303

Fig. 5 Spring-Lock Coupler - Typical

- 1 - MALE HALF SPRING-LOCK COUPLER
- 2 - FEMALE HALF SPRING-LOCK COUPLER
- 3 - SECONDARY CLIP
- 4 - CONNECTION INDICATOR RING
- 5 - COUPLER CAGE
- 6 - GARTER SPRING
- 7 - COUPLER CAGE
- 8 - "O" RINGS

REFRIGERANT OIL

DESCRIPTION

The refrigerant oil used in R-134a refrigerant systems is a synthetic-based, PolyAlkylene Glycol (PAG), wax-free lubricant. Mineral-based R-12 refrigerant oils are not compatible with PAG oils, and should never be introduced to an R-134a refrigerant system.

There are different PAG oils available, and each contains a different additive package. The SD7H15 compressor used in this vehicle is designed to use an SP-20 PAG refrigerant oil. Use only refrigerant oil of this same type to service the refrigerant system.

OPERATION

After performing any refrigerant recovery or recycling operation, always replenish the refrigerant system with the same amount of the recommended refrigerant oil as was removed. Too little refrigerant oil can cause compressor damage, and too much can reduce air conditioning system performance.

PAG refrigerant oil is much more hygroscopic than mineral oil, and will absorb any moisture it comes into contact with, even moisture in the air. The PAG oil container should always be kept tightly capped until it is ready to be used. After use, recap the oil container immediately to prevent moisture contamination.

DESCRIPTION AND OPERATION (Continued)

REFRIGERANT SYSTEM SERVICE PORTS**DESCRIPTION**

The two refrigerant system service ports are used to charge, recover/recycle, evacuate, and test the air conditioning refrigerant system. Unique service port coupler sizes are used on the R-134a system, to ensure that the refrigerant system is not accidentally contaminated by the use of the wrong refrigerant (R-12), or refrigerant system service equipment.

OPERATION

The high pressure service port is located on the liquid line between the condenser and the evaporator, near the front of the engine compartment. The low pressure service port is located on the compressor manifold, directly over the suction port of the compressor.

Each of the service ports has a threaded plastic protective cap installed over it from the factory. After servicing the refrigerant system, always reinstall both of the service port caps.

VACUUM CHECK VALVE**DESCRIPTION**

Two vacuum check valves are installed in the accessory vacuum supply line in the engine compartment. One check valve is located near the vacuum fitting on the power brake booster. The second check valve is located at the heater and air conditioner take-out of the accessory vacuum supply line. The vacuum check valves are designed to allow vacuum to flow in only one direction through the accessory vacuum supply circuits.

OPERATION

The use of the vacuum check valves help to maintain the system vacuum needed to retain the selected heater-A/C mode settings. The check valves will prevent the engine from bleeding down system vacuum through the intake manifold during extended heavy engine load (low engine vacuum) operation.

The vacuum check valves cannot be repaired and, if faulty or damaged, they must be individually replaced.

VACUUM RESERVOIR**DESCRIPTION**

The vacuum reservoir is mounted to the underside of the cowl plenum cover/grille panel in the right cowl plenum area. The cowl plenum cover/grille panel must be removed from the vehicle to access the vacuum reservoir for service.

OPERATION

Engine vacuum is stored in the vacuum reservoir. The stored vacuum is used to operate the vacuum-controlled vehicle accessories during periods of low engine vacuum such as when the vehicle is climbing a steep grade, or under other high engine load operating conditions.

The vacuum reservoir cannot be repaired and, if faulty or damaged, it must be replaced.

DIAGNOSIS AND TESTING**A/C PERFORMANCE**

The air conditioning system is designed to provide the passenger compartment with low temperature and low humidity air. The evaporators, located in the heater-A/C housing on the dash panel below the instrument panel and in the rear overhead A/C unit housing above the headliner, are cooled to temperatures near the freezing point. As warm damp air passes through the cooled evaporators, the air transfers its heat to the refrigerant in the evaporator tubes and the moisture in the air condenses on the evaporator fins. During periods of high heat and humidity, an air conditioning system will be more effective in the recirculation mode (Max-A/C). With the system in the recirculation mode, only air from the passenger compartment passes through the evaporator. As the passenger compartment air dehumidifies, the air conditioning system performance levels improve.

Humidity has an important bearing on the temperature of the air delivered to the interior of the vehicle. It is important to understand the effect that humidity has on the performance of the air conditioning system. When humidity is high, the evaporator has to perform a double duty. It must lower the air temperature, and it must lower the temperature of the moisture in the air that condenses on the evaporator fins. Condensing the moisture in the air transfers heat energy into the evaporator fins and tubing. This reduces the amount of heat the evaporator can absorb from the air. High humidity greatly reduces the ability of the evaporator to lower the temperature of the air.

However, evaporator capacity used to reduce the amount of moisture in the air is not wasted. Wringing some of the moisture out of the air entering the vehicle adds to the comfort of the passengers. Although, an owner may expect too much from their air conditioning system on humid days. A performance test is the best way to determine whether the system is performing up to standard. This test also provides valuable clues as to the possible cause of trouble with the air conditioning system.

DIAGNOSIS AND TESTING (Continued)

Review the Service Warnings and Precautions in the General Information section near the front of this group before performing this procedure. The air temperature in the test room and in the vehicle must be a minimum of 21° C (70° F) for this test.

(1) Connect a tachometer and a manifold gauge set.

(2) Set the heater-A/C mode control switch knob in the recirculation mode (Max-A/C) position, the temperature control knob in the full cool position, and the blower motor switch knob in the highest speed position.

(3) Start the engine and hold the idle at 1,000 rpm with the compressor clutch engaged. If the compressor clutch does not engage, see the A/C Diagnosis chart in the Diagnosis and Testing section of this group.

(4) The engine should be at operating temperature. The doors and windows must be closed and the hood must be mostly closed.

CAUTION: Never insert a thermometer probe into the outlet for the optional rear overhead A/C unit. Failure to observe this caution could result in damage to the rear blower wheel and/or the thermometer.

(5) Insert a thermometer in the driver side center A/C (panel) outlet for testing of the front unit, or hold a thermometer near the center outlets in the

headliner for testing of the rear unit. Operate the engine for five minutes.

(6) With the compressor clutch engaged, record the panel outlet or left center outlet discharge air temperature, the condenser out pressure (high side), and the compressor inlet pressure (low side). The compressor clutch may cycle, depending upon the ambient temperature and humidity. If the clutch cycles, use the readings obtained before the clutch disengaged.

(7) Compare the discharge air temperature reading to the Performance Temperature and Pressure chart. If the temperature reading is high for the rear unit, see Refrigerant System Leaks in the Diagnosis and Testing section of this group, and Refrigerant System Charge in the Service Procedures section of this group. If the temperature reading is high for the front unit, clamp off both heater hoses (inlet and outlet), wait five minutes and record the temperature again. Compare the second reading to the Performance Temperature and Pressure chart. If the temperature reading is now OK, see Temperature Control Cable in the Removal and Installation section and in the Adjustments section of this group. If the temperature reading is still too high, see Refrigerant System Leaks in the Diagnosis and Testing section of this group, and Refrigerant System Charge in the Service Procedures section of this group.

Performance Temperature and Pressure					
Ambient Temperature	21°C (70°F)	27°C (80°F)	32°C (90°F)	38°C (100°F)	43°C (110°F)
Maximum Allowable Air Temperature at Left Center Panel Outlet	9°C (48°F)	9°C (48°F)	12°C (54°F)	15°C (59°F)	18°C (65°F)
Compressor Inlet Pressure (Low Side)	138 to 207 kPa (20 to 30 psi)	138 to 207 kPa (20 to 30 psi)	172 to 241 kPa (25 to 35 psi)	214 to 283 kPa (31 to 41 psi)	255 to 324 kPa (37 to 47 psi)
Condenser Out Pressure at Service Port (High Side)	689 to 1034 kPa (100 to 150 psi)	931 to 1276 kPa (135 to 185 psi)	1172 to 1517 kPa (170 to 220 psi)	1448 to 1758 kPa (210 to 255 psi)	1689 to 2034 kPa (245 to 295 psi)

(8) Compare the discharge (high side) and suction (low side) pressure readings to the Performance Temperature and Pressure chart. If the pressures are

abnormal, suction pressure is not normal, see the A/C Diagnosis chart in the Diagnosis and Testing section of this group.

DIAGNOSIS AND TESTING (Continued)

A/C Diagnosis		
CONDITION	POSSIBLE CAUSE	CORRECTION
RAPID COMPRESSOR CLUTCH CYCLING (TEN OR MORE CYCLES PER MINUTE).	<ol style="list-style-type: none"> 1. Low refrigerant system charge. 2. Faulty electronic cycling clutch switch. 3. Faulty Powertrain Control Module (PCM). 	<ol style="list-style-type: none"> 1. See Refrigerant System Leaks in the Diagnosis and Testing section of this group. Test the refrigerant system for leaks. Repair, evacuate and charge the refrigerant system, if required. 2. See Electronic Cycling Clutch Switch in the Diagnosis and Testing section of this group. Test the electronic cycling clutch switch and replace, if required. 3. Refer to the proper Diagnostic Procedures manual for testing of the PCM. Test the PCM and replace, if required.
EQUAL PRESSURES, BUT THE COMPRESSOR CLUTCH DOES NOT ENGAGE.	<ol style="list-style-type: none"> 1. No refrigerant in the refrigerant system. 2. Faulty fuse. 3. Faulty compressor clutch coil. 4. Faulty compressor clutch relay. 5. Faulty electronic cycling clutch switch. 6. Faulty low pressure cut-off switch. 7. Faulty high pressure cut-off switch. 8. Faulty Powertrain Control Module (PCM). 9. Faulty heater-A/C control. 	<ol style="list-style-type: none"> 1. See Refrigerant System Leaks in the Diagnosis and Testing section of this group. Test the refrigerant system for leaks. Repair, evacuate and charge the refrigerant system, if required. 2. Check the fuses in the Power Distribution Center and the junction block. Repair the shorted circuit or component and replace the fuses, if required. 3. See Compressor Clutch Coil in the Diagnosis and Testing section of this group. Test the compressor clutch coil and replace, if required. 4. See Compressor Clutch Relay in the Diagnosis and Testing section of this group. Test the compressor clutch relay and relay circuits. Repair the circuits or replace the relay, if required. 5. See Electronic Cycling Clutch Switch in the Diagnosis and Testing section of this group. Test the electronic cycling clutch switch and replace, if required. 6. See Low Pressure Cut-Off Switch in the Diagnosis and Testing section of this group. Test the low pressure cut-off switch and replace, if required. 7. See High Pressure Cut-Off Switch in the Diagnosis and Testing section of this group. Test the high pressure cut-off switch and replace, if required. 8. Refer to the proper Diagnostic Procedures manual for testing of the PCM. Test the PCM and replace, if required. 9. See Heater-A/C Control in the Diagnosis and Testing section of this group. Test the heater-A/C control and replace, if required.
NORMAL PRESSURES, BUT A/C PERFORMANCE TEST AIR TEMPERATURES ARE TOO HIGH.	<ol style="list-style-type: none"> 1. Excessive refrigerant oil in system. 2. Temperature control cable improperly installed or faulty. 3. Blend-air door inoperative, obstructed or sealing improperly. 	<ol style="list-style-type: none"> 1. See Refrigerant Oil Level in the Service Procedures section of this group. Recover the refrigerant from the refrigerant system and inspect the refrigerant oil content. Restore the refrigerant oil to the proper level, if required. 2. See Temperature Control Cable in the Removal and Installation and Adjustments sections of this group. Inspect the temperature control cable for proper routing, operation and adjustment. Repair as required. 3. See Heater-A/C Housing Door in the Removal and Installation section of this group. Inspect the blend-air door for proper operation and sealing and correct, if required.

DIAGNOSIS AND TESTING (Continued)

A/C Diagnosis		
CONDITION	POSSIBLE CAUSE	CORRECTION
LOW SIDE PRESSURE IS NORMAL OR SLIGHTLY LOW, AND HIGH SIDE PRESSURE IS TOO LOW.	<ol style="list-style-type: none"> 1. Low refrigerant system charge. 2. Refrigerant flow through the evaporator coil is restricted. 3. Faulty compressor. 	<ol style="list-style-type: none"> 1. See Refrigerant System Leaks in the Diagnosis and Testing section of this group. Test the refrigerant system for leaks. Repair, evacuate and charge the refrigerant system, if required. 2. See Evaporator Coil in the Removal and Installation section of this group. Replace the restricted evaporator coil, if required. 3. See Compressor in the Diagnosis and Testing section of this group. Replace the compressor, if required.
LOW SIDE PRESSURE IS NORMAL OR SLIGHTLY HIGH, AND HIGH SIDE PRESSURE IS TOO HIGH.	<ol style="list-style-type: none"> 1. Condenser air flow restricted. 2. Inoperative cooling fan. 3. Faulty expansion valve. 4. Refrigerant system overcharged. 5. Air in the refrigerant system. 6. Engine overheating. 	<ol style="list-style-type: none"> 1. Check the condenser for damaged fins, foreign objects obstructing air flow through the condenser fins, and missing or improperly installed air seals. Refer to Group 7 - Cooling System for more information on air seals. Clean, repair, or replace components as required. 2. Refer to Group 7 - Cooling System for more information. Test the cooling fan and replace, if required. 3. See Expansion Valve in the Diagnosis and Testing section of this group. Replace the faulty expansion valve, if required. 4. See Refrigerant System Charge in the Service Procedures section of this group. Recover the refrigerant from the refrigerant system. Charge the refrigerant system to the proper level, if required. 5. See Refrigerant System Leaks in the Diagnosis and Testing section of this group. Test the refrigerant system for leaks. Repair, evacuate and charge the refrigerant system, if required. 6. Refer to Group 7 - Cooling System for more information. Test the cooling system and repair, if required.
LOW SIDE PRESSURE IS TOO HIGH, AND HIGH SIDE PRESSURE IS TOO LOW.	<ol style="list-style-type: none"> 1. Accessory drive belt slipping. 2. Faulty compressor. 	<ol style="list-style-type: none"> 1. Refer to Group 7 - Cooling System for more information. Inspect the accessory drive belt condition and tension. Tighten or replace the accessory drive belt, if required. 2. See Compressor in the Diagnosis and Testing section of this group. Replace the compressor, if required.
LOW SIDE PRESSURE IS TOO LOW, AND HIGH SIDE PRESSURE IS TOO HIGH.	<ol style="list-style-type: none"> 1. Restricted refrigerant flow through the refrigerant lines. 2. Restricted refrigerant flow through the expansion valve. 3. Restricted refrigerant flow through the condenser. 4. Restricted refrigerant flow through the filter-drier. 	<ol style="list-style-type: none"> 1. See Liquid Line and Suction and Discharge Line in the Removal and Installation section of this group. Inspect the refrigerant lines for kinks, tight bends or improper routing. Correct the routing or replace the refrigerant line, if required. 2. See Expansion Valve in the Diagnosis and Testing section of this group. Replace the restricted expansion valve, if required. 3. See Condenser in the Removal and Installation section of this group. Replace the restricted condenser, if required. 4. See Filter-Drier in the Removal and Installation section of this group. Replace the restricted filter-drier, if required.

DIAGNOSIS AND TESTING (Continued)

BLOWER MOTOR

WARNING: ON VEHICLES EQUIPPED WITH AIRBAGS, REFER TO PASSIVE RESTRAINT SYSTEMS BEFORE ATTEMPTING ANY STEERING WHEEL, STEERING COLUMN, OR INSTRUMENT PANEL COMPONENT DIAGNOSIS OR SERVICE. FAILURE TO TAKE THE PROPER PRECAUTIONS COULD RESULT IN ACCIDENTAL AIRBAG DEPLOYMENT AND POSSIBLE PERSONAL INJURY.

For circuit descriptions and diagrams, refer to Air Conditioning/Heater in Group 8W - Wiring Diagrams. Possible causes of an inoperative front or rear blower motor include:

- Faulty fuse (the rear blower motor fuse is located in the relay and fuse block located on the back of the junction block)
- Faulty blower motor circuit wiring or wire harness connectors
- Faulty blower motor resistor
- Faulty blower motor relay (Voltage Reduction Relay or VRR) (front only)
- Faulty blower motor switch
- Faulty heater-A/C mode control switch (front only)
- Faulty high speed blower motor relay (front only)
- Faulty blower motor.

Possible causes of the front or rear blower motor not operating in all speeds include:

- Faulty fuse (the rear blower motor fuse is located in the relay and fuse block located on the back of the junction block)
- Faulty blower motor switch
- Faulty blower motor resistor
- Faulty blower motor relay (front only)
- Faulty blower motor circuit wiring or wire harness connectors
- Faulty high speed blower motor relay (front only).

VIBRATION

Possible causes of front or rear blower motor vibration include:

- Improper blower motor mounting
- Improper blower wheel mounting
- Blower wheel out of balance or deformed
- Blower motor faulty.

NOISE

To determine that the rear blower is the source of the noise, simply switch the blower motor from off to on. There are no other moving parts involved in the rear overhead A/C unit, which makes it simple to identify the source of the noise. To verify that the

front blower is the source of the noise, unplug the front blower motor wire harness connector and operate the heater-A/C system. If the noise goes away, possible causes include:

- Foreign material in the heater-A/C housing
- Improper blower motor mounting
- Improper blower wheel mounting
- Blower motor faulty.

BLOWER MOTOR RELAY

RELAY TEST

The blower motor relay (Voltage Reduction Relay or VRR) (Fig. 6) is mounted with a single screw directly to the instrument panel's structural plastic inside the glove box opening, next to the left-side energy-absorbing bracket (Fig. 7). Remove the blower motor relay to perform the following tests:

(1) A relay in the de-energized position should have continuity between terminals 87A and 30, and no continuity between terminals 87 and 30. If OK, go to Step 2. If not OK, replace the faulty relay.

(2) Resistance between terminals 85 and 86 (electromagnet) should be 75 ± 5 ohms. If OK, go to Step 3. If not OK, replace the faulty relay.

(3) Connect a battery to terminals 85 and 86. There should now be continuity between terminals 30 and 87, and no continuity between terminals 87A and 30. If OK, see Relay Circuit Test in the Diagnosis and Testing section of this group. If not OK, replace the faulty relay.

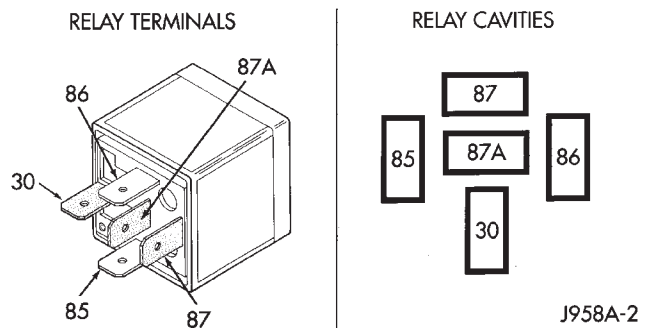

TERMINAL LEGEND	
NUMBER	IDENTIFICATION
30	COMMON FEED
85	COIL GROUND
86	COIL BATTERY
87	NORMALLY OPEN
87A	NORMALLY CLOSED

Fig. 6 Blower Motor Relay

DIAGNOSIS AND TESTING (Continued)

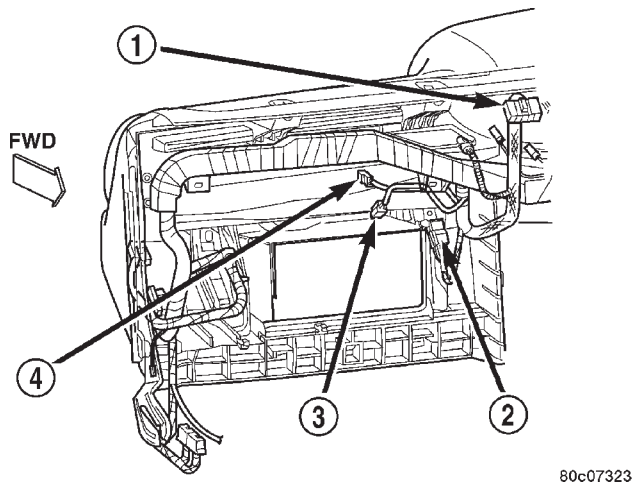

Fig. 7 Blower Motor Relay (VRR) Location

- 1 - BLOWER MOTOR RESISTOR CONNECTOR
- 2 - BLOWER MOTOR RELAY
- 3 - BLOWER MOTOR CONNECTOR
- 4 - GLOVE BOX LAMP CONNECTOR

RELAY CIRCUIT TEST

For circuit descriptions and diagrams, refer to Air Conditioning/Heater in Wiring Diagrams.

(1) The relay common feed terminal cavity (30) is connected to fused battery feed directly from a fuse in the Power Distribution Center (PDC), and should be hot at all times. Check for battery voltage at the PDC cavity for relay terminal 30. If OK, go to Step 2. If not OK, repair the open circuit to the PDC fuse as required.

(2) The relay normally closed terminal cavity (87A) is not used for this application. Go to Step 3.

(3) The relay normally open terminal cavity (87) is connected to the blower motor. When the relay is energized, terminal 87 is connected to terminal 30 and provides full battery current to the blower motor feed circuit. There should be continuity between the PDC cavity for terminal 87 and the blower motor relay output circuit cavity of the blower motor wire harness connector at all times. If OK, go to Step 4. If not OK, repair the open circuit to the blower motor as required.

(4) The coil battery terminal cavity (86) is connected to the ignition switch. When the ignition switch is placed in the On position, fused ignition switch output is directed from a fuse in the junction block to the relay electromagnetic coil to energize the relay. There should be battery voltage at the PDC cavity for relay terminal 86 with the ignition switch in the On position. If OK, go to Step 5. If not OK, repair the open circuit to the junction block fuse as required.

(5) The coil ground terminal cavity (85) is connected to ground. This terminal supplies the ground

for the relay electromagnetic coil. There should be continuity between the PDC cavity for relay terminal 85 and a good ground at all times. If not OK, repair the open circuit as required.

ADDITIONAL RELAY CIRCUIT TESTING

- The relay common feed terminal cavity 30 is connected to the low side of the blower motor. When the blower switch is Off and the ignition is On, there should be battery voltage present on this circuit. When the ignition switch is On, the voltage at that point should vary based on blower switch position.

- The normally closed contact cavity 87A is connected to the resistor block cavity 3. Check this circuit by turning the blower switch to High and cycling between Heat and A/C modes. The voltage in the Heat mode should be approximately 2 volts. The blower switch must be in High blower speed position during this check.

- The normally open contact on cavity 87 is tied to both the resistor block cavity 6 and the HVAC blower switch cavity 6. Check for continuity on this circuit.

- The coil B+ contact cavity 86 is connected to an ignition run start feed. Battery voltage should be present on this circuit when the ignition switch is in the Run position.

- The coil ground (-) cavity 85 is connected to the HVAC switch cavity 2 as well as the JTEC and A/C high pressure switch. Battery voltage should be present on this circuit when the ignition switch is in the Run position and a Heat mode is selected on the control head. When an A/C mode is selected, the voltage at this point should be less than 1 volt.

- If the blower motor does not operate, or only operates in some modes, check for a faulty connection at the VRR, or defective blower motor relay (VRR).

BLOWER MOTOR RESISTOR

Both the front blower motor resistor and the optional rear overhead A/C unit blower motor resistor can be diagnosed using the procedure that follows. For circuit descriptions and diagrams, refer to 8W-42 - Air Conditioning/Heater in Group 8W - Wiring Diagrams.

WARNING: ON VEHICLES EQUIPPED WITH AIR-BAGS, REFER TO GROUP 8M - PASSIVE RESTRAINT SYSTEMS BEFORE ATTEMPTING ANY STEERING WHEEL, STEERING COLUMN, OR INSTRUMENT PANEL COMPONENT DIAGNOSIS OR SERVICE. FAILURE TO TAKE THE PROPER PRECAUTIONS COULD RESULT IN ACCIDENTAL AIR-BAG DEPLOYMENT AND POSSIBLE PERSONAL INJURY.

(1) Disconnect and isolate the battery negative cable.

DIAGNOSIS AND TESTING (Continued)

(2) Unplug the wire harness connector from the blower motor resistor.

(3) Check for continuity between each of the blower motor switch input terminals of the resistor and the resistor output terminal. In each case there should be continuity. If OK, repair the wire harness circuits between the blower motor switch and the blower motor resistor or blower motor as required. If not OK, replace the faulty blower motor resistor.

BLOWER MOTOR SWITCH**FRONT**

For circuit descriptions and diagrams, refer to 8W-42 - Air Conditioning/Heater in Group 8W - Wiring Diagrams.

WARNING: ON VEHICLES EQUIPPED WITH AIR-BAGS, REFER TO GROUP 8M - PASSIVE RESTRAINT SYSTEMS BEFORE ATTEMPTING ANY STEERING WHEEL, STEERING COLUMN, OR INSTRUMENT PANEL COMPONENT DIAGNOSIS OR SERVICE. FAILURE TO TAKE THE PROPER PRECAUTIONS COULD RESULT IN ACCIDENTAL AIR-BAG DEPLOYMENT AND POSSIBLE PERSONAL INJURY.

(1) Check for battery voltage at the fuse in the Power Distribution Center (PDC). If OK, go to Step 2. If not OK, repair the shorted circuit or component as required and replace the faulty fuse.

(2) Turn the ignition switch to the Off position. Disconnect and isolate the battery negative cable. Remove the heater-A/C control from the instrument panel. Check for continuity between the ground circuit cavity of the heater-A/C control wire harness connector and a good ground. There should be continuity. If OK, go to Step 3. If not OK, repair the open circuit to ground as required.

(3) With the heater-A/C control wire harness connector unplugged, place the heater-A/C mode control switch knob to any position except the Off position. Check for continuity between the ground circuit terminal and each of the blower motor driver circuit terminals of the heater-A/C control as you move the blower motor switch knob to each of the four speed positions. There should be continuity at each driver circuit terminal in only one blower motor switch speed position. If OK, test and repair the blower driver circuits between the heater-A/C control connector and the blower motor resistor as required. If not OK, replace the faulty heater-A/C control unit.

REAR

For circuit descriptions and diagrams, refer to 8W-42 - Air Conditioning/Heater in Group 8W - Wiring Diagrams.

(1) Turn the ignition switch to the Off position. Disconnect and isolate the battery negative cable. Remove the rear blower motor switch from the headliner. Check for continuity between the ground circuit cavity of the rear blower motor switch wire harness connector and a good ground. There should be continuity. If OK, go to Step 2. If not OK, repair the open circuit to ground as required.

(2) With the rear blower motor switch wire harness connector unplugged, place the rear blower motor switch knob to any position except the Off position. Check for continuity between the ground circuit terminal and each of the blower motor driver circuit terminals of the rear blower motor switch as you move the blower motor switch knob to each of the three speed positions. There should be continuity at each driver circuit terminal in only one blower motor switch speed position. If OK, test and repair the rear blower driver circuits between the rear blower motor switch wire harness connector and the blower motor resistor as required. If not OK, replace the faulty rear blower motor switch.

COMPRESSOR

When investigating an air conditioning related noise, you must first know the conditions under which the noise occurs. These conditions include: weather, vehicle speed, transmission in gear or neutral, engine speed, engine temperature, and any other special conditions. Noises that develop during air conditioning operation can often be misleading. For example: What sounds like a failed front bearing or connecting rod, may be caused by loose bolts, nuts, mounting brackets, or a loose compressor clutch assembly.

Drive belts are speed sensitive. At different engine speeds and depending upon belt tension, belts can develop noises that are mistaken for a compressor noise. Improper belt tension can cause a misleading noise when the compressor clutch is engaged, which may not occur when the compressor clutch is disengaged. Check the serpentine drive belt condition and tension as described in Cooling System before beginning this procedure.

(1) Select a quiet area for testing. Duplicate the complaint conditions as much as possible. Switch the compressor on and off several times to clearly identify the compressor noise. Listen to the compressor while the clutch is engaged and disengaged. Probe the compressor with an engine stethoscope or a long screwdriver with the handle held to your ear to better localize the source of the noise.

(2) Loosen all of the compressor mounting hardware and retighten. Tighten the compressor clutch mounting nut. Be certain that the clutch coil is mounted securely to the compressor, and that the

DIAGNOSIS AND TESTING (Continued)

clutch plate and pulley are properly aligned and have the correct air gap. See Compressor and Compressor Clutch in the Removal and Installation section of this group for the procedures.

(3) To duplicate a high-ambient temperature condition (high head pressure), restrict the air flow through the condenser. Install a manifold gauge set to be certain that the discharge pressure does not exceed 2760 kPa (400 psi).

(4) Check the refrigerant system plumbing for incorrect routing, rubbing or interference, which can cause unusual noises. Also check the refrigerant lines for kinks or sharp bends that will restrict refrigerant flow, which can cause noises. See Suction and Discharge Line in the Removal and Installation section of this group for more information.

(5) If the noise is from opening and closing of the high pressure relief valve due to excessive discharge pressure, evacuate and recharge the refrigerant system. See Refrigerant System Evacuate and Refrigerant System Charge in the Service Procedures section of this group. Check the condenser, fan(s), and refrigerant charge level. The venting of refrigerant by the high pressure relief valve indicates a system malfunction, not necessarily a relief valve problem requiring replacement of the compressor.

(6) If the noise is from liquid slugging on the suction line, replace the filter-drier. See Filter-Drier in the Removal and Installation section of this group for the procedures. Check the refrigerant oil level and the refrigerant system charge. See Refrigerant Oil Level and Refrigerant System Charge in the Service Procedures section of this group.

(7) If the noise continues, replace the compressor and repeat Step 1.

COMPRESSOR CLUTCH COIL

For circuit descriptions and diagrams, refer to 8W-42 - Air Conditioning/Heater in Group 8W - Wiring Diagrams. The battery must be fully-charged before performing the following tests. Refer to Group 8A - Battery for more information.

(1) Connect an ammeter (0 to 10 ampere scale) in series with the clutch coil terminal. Use a voltmeter (0 to 20 volt scale) with clip-type leads for measuring the voltage across the battery and the compressor clutch coil.

(2) With the heater-A/C mode control switch in any A/C mode, and the blower motor switch in the lowest speed position, start the engine and run it at normal idle.

(3) The compressor clutch coil voltage should read within two volts of the battery voltage. If there is voltage at the clutch coil, but the reading is not within two volts of the battery voltage, test the clutch coil feed circuit for excessive voltage drop and

repair as required. If there is no voltage reading at the clutch coil, use a DRB scan tool and the proper Diagnostic Procedures manual for testing of the compressor clutch circuit. The following components must be checked and repaired as required before you can complete testing of the clutch coil:

- Fuses in the junction block and the Power Distribution Center (PDC)
- Heater-A/C mode control switch
- Compressor clutch relay
- Electronic clutch cycling switch
- High pressure cut-off switch
- Low pressure cut-off switch
- Powertrain Control Module (PCM).

(4) The compressor clutch coil is acceptable if the current draw measured at the clutch coil is 2.0 to 3.9 amperes with the electrical system voltage at 11.5 to 12.5 volts. This should only be checked with the work area temperature at 21° C (70° F). If system voltage is more than 12.5 volts, add electrical loads by turning on electrical accessories until the system voltage drops below 12.5 volts.

(a) If the clutch coil current reading is four amperes or more, the coil is shorted and should be replaced.

(b) If the clutch coil current reading is zero, the coil is open and should be replaced.

COMPRESSOR CLUTCH RELAY

RELAY TEST

The compressor clutch relay (Fig. 8) is located in the Power Distribution Center (PDC). Refer to the PDC label for relay identification and location. Remove the relay from the PDC to perform the following tests:

(1) A relay in the de-energized position should have continuity between terminals 87A and 30, and no continuity between terminals 87 and 30. If OK, go to Step 2. If not OK, replace the faulty relay.

(2) Resistance between terminals 85 and 86 (electromagnet) should be 75 ± 5 ohms. If OK, go to Step 3. If not OK, replace the faulty relay.

(3) Connect a battery to terminals 85 and 86. There should now be continuity between terminals 30 and 87, and no continuity between terminals 87A and 30. If OK, see Relay Circuit Test in the Diagnosis and Testing section of this group. If not OK, replace the faulty relay.

RELAY CIRCUIT TEST

For circuit descriptions and diagrams, refer to 8W-42 - Air Conditioning/Heater in Group 8W - Wiring Diagrams.

(1) The relay common feed terminal cavity (30) is connected to fused battery feed. There should be bat-

DIAGNOSIS AND TESTING (Continued)

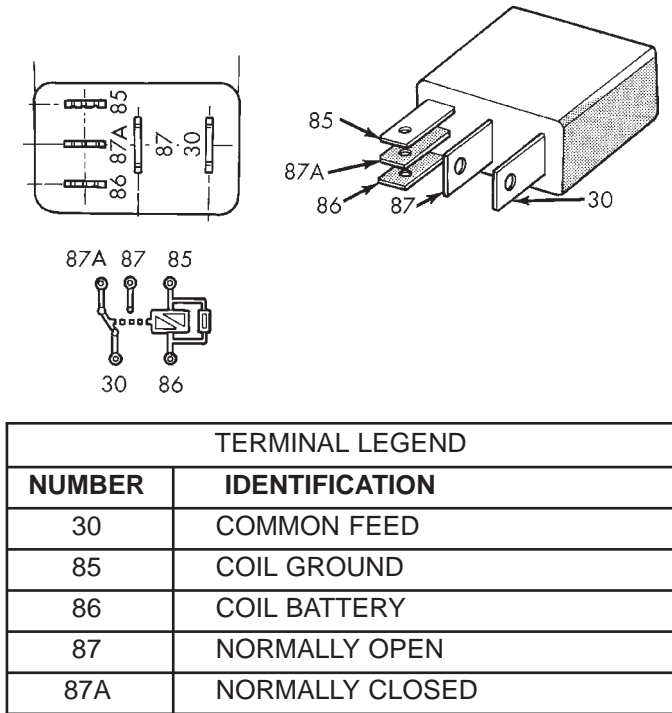

Fig. 8 Compressor Clutch Relay

tery voltage at the cavity for relay terminal 30 at all times. If OK, go to Step 2. If not OK, repair the open circuit to the fuse in the PDC as required.

(2) The relay normally closed terminal (87A) is not used in this application. Go to Step 3.

(3) The relay normally open terminal cavity (87) is connected to the compressor clutch coil. There should be continuity between this cavity and the A/C compressor clutch relay output circuit cavity of the compressor clutch coil wire harness connector. If OK, go to Step 4. If not OK, repair the open circuit as required.

(4) The relay coil battery terminal (86) is connected to the fused ignition switch output (run/start) circuit. There should be battery voltage at the cavity for relay terminal 86 with the ignition switch in the On position. If OK, go to Step 5. If not OK, repair the open circuit to the fuse in the junction block as required.

(5) The coil ground terminal cavity (85) is switched to ground through the Powertrain Control Module (PCM). There should be continuity between this cavity and the A/C compressor clutch relay control circuit cavity of the PCM wire harness connector C (gray) at all times. If not OK, repair the open circuit as required.

ELECTRONIC CYCLING CLUTCH SWITCH (Front Unit Only)

For circuit descriptions and diagrams, refer to 8W-42 - Air Conditioning/Heater in Group 8W - Wir-

ing Diagrams. Use a volt/ohmmeter to test the electronic cycling clutch switch. Verify that the refrigerant system has the correct refrigerant charge. Check that both the low and high pressure cut-off switches are functional as described in the Diagnosis and Testing section of this group before testing the electronic cycling clutch switch.

(1) Disconnect and isolate the battery negative cable. Unplug the wire harness connectors at the electronic cycling clutch switch and the high pressure cut-off switch. Check for continuity between the C90A circuit cavities in the body half of the electronic cycling clutch switch wire harness connector and the high pressure cut-off switch wire harness connector. There should be continuity. If OK, go to Step 2. If not OK, repair the open circuit as required.

(2) Unplug the wire harness connector at the low pressure cut-off switch. Check for continuity between the C2 circuit cavities in the body half of the electronic cycling clutch switch wire harness connector and the low pressure cut-off switch wire harness connector. There should be continuity. If OK, go to Step 3. If not OK, repair the open circuit as required.

(3) Plug in the wire harness connectors at the low pressure cut-off and high pressure cut-off switches. Connect the battery negative cable. Turn the ignition switch to the On position. Check for battery voltage at the fused ignition switch output (run) circuit cavity in the body half of the electronic cycling clutch switch wire harness connector. If OK, go to Step 4. If not OK, repair the open circuit to the junction block as required.

(4) Plug in the wire harness connector at the electronic cycling clutch switch. With the ambient temperature from 20 to 30° C (68 to 90° F), start the engine and set the heater-A/C mode control switch in any A/C position. If the compressor clutch fails to engage, use a DRBIII® scan tool and the proper Diagnostic Procedures manual to check the Powertrain Control Module (PCM) and its inputs and outputs. If the compressor clutch engages, the clutch should cycle on and off two to three times per minute. If the clutch fails to cycle at this rate in these ambient temperatures, replace the faulty electronic cycling clutch switch.

NOTE: If the ambient temperature is above 32° C (90° F) the compressor clutch may stay engaged and not cycle due to the high heat load. This condition is normal.

EXPANSION VALVE

These tests must be made at an ambient temperature of 21 to 29° C (70 to 85° F). Disconnect the wire connector at the low pressure cut off switch. Use a jumper wire to jumper terminals at the connector.

DIAGNOSIS AND TESTING (Continued)

FRONT (ONLY)

(1) Attach a manifold gauge set. Close the vehicle doors and windows, start the engine, and hold the engine speed at 1,000 rpm. Set the heater-A/C mode control switch knob to the recirculation mode (Max A/C) position, the temperature control knob to the full hot position, and the blower motor switch to the highest speed position.

(2) Operate the air conditioning system for at least five minutes to stabilize the system, and to provide sufficient reheat to load the evaporator. The discharge pressure (high side) at the service port should reach 966 to 1656 kPa (140 to 240 psi). If this discharge pressure cannot be obtained, check the refrigerant system charge. See Refrigerant System Charge in the Service Procedures section of this group.

WARNING: EXTREME CARE MUST BE USED WHEN HANDLING LIQUID CARBON DIOXIDE (CO²), AS SKIN INJURY CAN OCCUR. PROTECTIVE GLOVES SHOULD BE WORN.

(3) Apply liquid carbon dioxide (CO²) to the expansion valve control head (completely cover the head) for a minimum of thirty seconds. Observe the manifold gauge set. The suction pressure (low side) must drop to below 50 kPa (7.25 psi). If this reading is not obtained, the expansion valve is faulty and must be replaced.

(4) Remove the liquid carbon dioxide (CO²) from the control head. Observe the manifold gauge set. The suction pressure (low side) must increase to a minimum of 262 kPa (38 psi), and then stabilize to a pressure of 172 to 240 kPa (25 to 35 psi). If these readings are not obtained, the expansion valve is faulty and must be replaced.

(5) Set the engine idle speed at 1,000 rpm and the blower motor switch to the highest speed position. The suction pressure (low side) should be 138 to 207 kPa (20 to 30 psi). If the discharge pressure (high side) is higher than 1656 kPa (240 psi), check for a restricted discharge line. Also check the engine cooling system for overheating, air trapped in the system, or a faulty fan drive. If the discharge pressure (high side) is less than 966 kPa (140 psi), check for a faulty compressor.

FRONT AND REAR A/C

(1) Attach a manifold gauge set. Close the vehicle doors and windows, start the engine, and hold the engine speed at 1,000 rpm. Set the heater-A/C mode control switch knob to the recirculation mode (Max A/C) position, the temperature control knob to the full hot position, and both the front and rear blower motor switches to their highest speed positions.

(2) Operate the air conditioning system for at least five minutes to stabilize the system, and to provide

sufficient reheat to load the front and rear evaporators. The discharge pressure (high side) at the service port should reach 966 to 1656 kPa (140 to 240 psi). If this discharge pressure cannot be obtained, check the refrigerant system charge. See Refrigerant System Charge in the Service Procedures section of this group.

WARNING: EXTREME CARE MUST BE USED WHEN HANDLING LIQUID CARBON DIOXIDE (CO²) AS SKIN INJURY CAN OCCUR. PROTECTIVE GLOVES SHOULD BE WORN.

(3) Both the front and rear expansion valves should be checked for correct operation. Apply liquid carbon dioxide (CO²) to the front expansion valve control head (completely cover the head) for a minimum of thirty seconds. Observe the manifold gauge set. The suction pressure (low side) must drop to below 50 kPa (7.25 psi). If this reading is not obtained, the expansion valve is faulty and must be replaced.

(4) Apply liquid carbon dioxide (CO²) to the front expansion valve control head (completely cover the head) for a minimum of thirty seconds. Remove the protective cover and apply liquid carbon dioxide (CO²) to the rear expansion valve control head. Grasp the suction line (large line) off the evaporator with a bare hand and hold it for at least two minutes. Use the same procedure with the front expansion valve. Grasp the suction line jumper below the expansion valve (before the rear suction line tee) with a bare hand and hold for at least two minutes. When testing the front expansion valve, place the rear blower motor switch in the Off position.

(5) With a correctly operating expansion valve, the suction line will feel warm with the closing of the valve (cold applied). Then the line will cool sharply within two minutes as the valve opens. If this temperature change does not occur, the expansion valve is faulty and must be replaced.

HEATER-A/C CONTROL

Satisfactory heater and air conditioner performance depends upon proper operation and adjustment of all operating controls and refrigeration system components. For circuit descriptions and diagrams, refer to 8W-42 - Air Conditioning/Heater in Group 8W - Wiring Diagrams. These inspections, tests, and adjustments should be used to locate the cause of a malfunction.

Operation must be tested as described in the following sequence:

(1) Move the temperature control knob quickly to the full hot and the full cold positions. There should be a distinct sound of the blend-air door hitting its stops within the heater-A/C housing at the end of

DIAGNOSIS AND TESTING (Continued)

knob travel in each direction, with no spring-back of the knob. If not OK, inspect the condition, routing, installation and adjustment of the temperature control cable. See Temperature Control Cable in the Removal and Installation section and in the Adjustments section of this group for more information.

(2) Inspect and adjust the serpentine drive belt. Refer to Group 7 - Cooling System for the procedures.

(3) Start the engine and hold the idle speed at 1,300 rpm.

(4) On vehicles with air conditioning, turn the temperature control knob to the extreme counter-clockwise (Cool) position, and set the mode control switch knob in the Bi-Level (A/C) position. The outside (recirculation) air door should be open to outside air. If not OK, see Vacuum System in the Diagnosis and Testing section of this group.

(5) Open the vehicle windows. Test the blower motor operation in all speeds. If not OK, see Blower Motor in the Diagnosis and Testing section of this group. Leave the blower motor switch knob in the highest speed position.

(6) On vehicles with air conditioning, the compressor should be running and the air conditioning system in operation unless the ambient air temperature is below about -1° C (30° F). If not OK, see A/C Performance in the Diagnosis and Testing section of this group.

(7) Check the mode control switch operation. The heater and air conditioner systems should respond as described in the owner's manual in the vehicle glove box to each mode selected. Reduce the engine speed

to normal idle. The vacuum will be high at low idle and the vacuum actuators should respond quickly. If not OK, see Vacuum System in the Diagnosis and Testing section of this group.

(8) If the vacuum tests, and the electrical component and circuit tests reveal no problems, disassemble the heater-A/C housing to inspect for mechanical misalignment or binding of the mode doors.

HEATER PERFORMANCE

Before performing the following tests, refer to Group 7 - Cooling System for the procedures to check the engine coolant level and flow, engine coolant reserve/recovery system operation, accessory drive belt condition and tension, radiator air flow and the fan drive operation. Also be certain that the accessory vacuum supply line is connected at the engine vacuum source.

MAXIMUM HEATER OUTPUT

Engine coolant is delivered to the heater core through two heater hoses. With the engine idling at normal operating temperature, set the temperature control knob in the full hot position, the mode control switch knob in the floor position, and the blower motor switch knob in the highest speed position. Using a test thermometer, check the temperature of the air being discharged at the heater-A/C housing floor outlets. Compare the test thermometer reading to the Temperature Reference chart.

Temperature Reference				
Ambient Air Temperature	15.5° C (60° F)	21.1° C (70° F)	26.6° C (80° F)	32.2° C (90° F)
Minimum Heater System Air Outlet Temperature	52.2° C (126° F)	56.1° C (133° F)	59.4° C (139° F)	62.2° C (144° F)

If the floor outlet air temperature is too low, refer to Group 7 - Cooling System to check the engine coolant temperature specifications. Both of the heater hoses should be hot to the touch. The coolant return heater hose should be slightly cooler than the coolant supply heater hose. If the return hose is much cooler than the supply hose, locate and repair the engine coolant flow obstruction in the cooling system. Refer to Group 7 - Cooling System for the procedures.

An alternate method of checking heater performance is to use a DRB scan tool to monitor the engine coolant temperature. The floor outlet air temperature reading should be no more than 4.5° C (40° F) lower than the engine coolant temperature reading.

OBSTRUCTED COOLANT FLOW

- Faulty water pump.
- Faulty thermostat.
- Pinched or kinked heater hoses.
- Improper heater hose routing.
- Plugged heater hoses or supply and return ports at the cooling system connections.
- A plugged heater core.

If proper coolant flow through the cooling system is verified, and heater outlet air temperature is still low, a mechanical problem may exist.

MECHANICAL PROBLEMS

Possible locations or causes of insufficient heat:

- An obstructed cowl air intake.
- Obstructed heater system outlets.

DIAGNOSIS AND TESTING (Continued)

- A faulty, obstructed or improperly installed blend-air door.
- The temperature control cable is not connected, or is not routed or adjusted properly.
- A faulty blower system.
- A faulty heater-A/C control.

TEMPERATURE CONTROL

If the heater outlet air temperature cannot be adjusted with the temperature control knob on the

heater-A/C control panel, the following could require service:

- A faulty heater-A/C control.
- The temperature control cable is not connected, or is not routed or adjusted properly.
- A faulty, obstructed or improperly installed blend-air door.
- An obstructed cowl air intake.
- The engine cooling system.

Heater Diagnosis		
CONDITION	POSSIBLE CAUSE	CORRECTION
INSUFFICIENT HEATER OUTPUT.	<ol style="list-style-type: none"> 1. Incorrect engine coolant level. 2. Air trapped in engine cooling system. 3. Incorrect engine coolant temperature. 4. Temperature control cable improperly installed or not adjusted. 5. Blend-air door not operating properly. 6. Insufficient air flow through heater housing. 7. Improper blower motor operation. 	<ol style="list-style-type: none"> 1. Check the engine coolant level. Refer to Group 7 - Cooling System for the procedures. 2. Check the operation of the coolant reserve/recovery system. Refer to Group 7 - Cooling System for the procedures. 3. Check the performance and operation of the engine cooling system including: thermostat, water pump, fan drive, accessory drive belt, coolant flow (plugged radiator or heater core, plugged or kinked coolant hoses), air flow (missing or improperly installed radiator air seals or fan shroud). Refer to Group 7 - Cooling System for the procedures. 4. See Temperature Control Cable in the Removal and Installation and in the Adjustments sections of this group. 5. Check for a damaged, obstructed or improperly installed blend-air door or seals. See Heater-A/C Housing Door in the Removal and Installation section of this group. 6. Remove foreign material or obstructions from cowl air intake. 7. See Blower Motor in the Diagnosis and Testing section of this group.

DUAL FUNCTION HIGH PRESSURE SWITCH/HIGH PRESSURE CUT-OFF SWITCH

Before performing diagnosis of the dual function high pressure switch, or the high pressure cut-off switch, verify that the refrigerant system has the correct refrigerant charge. See Refrigerant System Charge in the Service Procedures section of this group for more information.

For circuit descriptions and diagrams, refer to 8W-42 - Air Conditioning/Heater in Group 8W - Wiring Diagrams.

- (1) Disconnect and isolate the battery negative cable.
- (2) Unplug the high pressure switch wire harness connector from the switch on the refrigerant system fitting.
- (3) On the dual function high pressure switch, check for continuity between terminals C and D. On

the two terminal switch, check for continuity between both terminals of the high pressure cut-off switch. There should be continuity. If OK, test and repair the A/C switch sense circuit as required. If not OK, replace the faulty switch.

LOW PRESSURE CUT-OFF SWITCH

Before performing diagnosis of the low pressure cut-off switch, remember that lower ambient temperatures, below about -1° C (30° F), during cold weather will open the switch contacts and prevent compressor operation due to the pressure/temperature relationship of the refrigerant.

Also verify that the refrigerant system has the correct refrigerant charge. See Refrigerant System Charge in the Service Procedures section of this group for more information.

For circuit descriptions and diagrams, refer to Air Conditioning/Heater in Wiring Diagrams.

DIAGNOSIS AND TESTING (Continued)

- (1) Disconnect and isolate the battery negative cable.
- (2) Unplug the low pressure cut-off switch wire harness connector from the switch on the suction line jumper fitting.
- (3) Install a jumper wire between the two cavities of the low pressure cut-off switch wire harness connector.
- (4) Connect a manifold gauge set to the refrigerant system service ports. See Refrigerant System Service Equipment and Refrigerant System Service Ports in the Description and Operation section of this group for more information.
- (5) Connect the battery negative cable.
- (6) Place the heater-A/C mode control switch knob in any A/C position and start the engine.
- (7) Check for continuity between the two terminals of the low pressure cut-off switch. There should be continuity with a suction pressure (low side) reading of 48 to 193 kPa (15 to 28 psi) or above, and no continuity with a suction pressure reading of 90 kPa (13 psi) or below. If OK, test and repair the A/C switch sense circuit as required. If not OK, replace the faulty switch.

REFRIGERANT SYSTEM LEAKS

WARNING: REVIEW THE WARNINGS AND CAUTIONS IN THE GENERAL INFORMATION SECTION NEAR THE FRONT OF THIS GROUP BEFORE LEAK TESTING THE SYSTEM.

If the air conditioning system does not cool properly, the A/C system performance should be tested. See A/C Performance in the Diagnosis and Testing section of this group for the procedures. If the A/C system refrigerant fill is found to be low or if the system is empty; a leak at a refrigerant line, connector fitting, component, or component seal is likely.

An electronic leak detector designed for R-134a refrigerant, or a fluorescent R-134a leak detection dye and a black light are recommended for locating and confirming refrigerant system leaks. Refer to the operating instructions supplied by the equipment manufacturer for the proper care and use of this equipment.

An oily residue on or near refrigerant system lines, connector fittings, components, or component seals can indicate the general location of a possible refrigerant leak. However, the exact leak location should be confirmed with an electronic leak detector prior to component repair or replacement.

To detect a leak in the refrigerant system with an electronic leak detector, perform one of the following procedures:

SYSTEM EMPTY

- (1) Evacuate the refrigerant system. See Refrigerant System Evacuate in the Service Procedures section of this group.
- (2) Connect and dispense 0.283 kilograms (0.625 pounds or 10 ounces) of R-134a refrigerant into the evacuated refrigerant system. See Refrigerant System Charge in the Service Procedures section of this group.
- (3) Position the vehicle in a wind-free work area. This will aid in detecting small leaks.
- (4) With the engine not running, use an electronic R-134a leak detector and search for leaks. Because R-134a refrigerant is heavier than air, the leak detector probe should be moved slowly along the bottom side of all refrigerant lines, connector fittings and components.

CAUTION: Never insert a leak detector probe into the outlet for the optional rear overhead A/C unit. Failure to observe this caution could result in damage to the rear blower wheel and/or the leak detector.

- (5) To inspect the evaporator coil for leaks, insert the electronic leak detector probe into the center instrument panel outlet and the floor duct outlet, or near the outside of the rear overhead A/C unit outlet bezel. Set the front or rear blower motor switch to the lowest speed position, and the mode control switch to the recirculation mode (Max-A/C).

SYSTEM LOW

- (1) Position the vehicle in a wind-free work area. This will aid in detecting small leaks.
- (2) Bring the refrigerant system up to operating temperature and pressure. This is done by allowing the engine to run with the air conditioning system turned on for five minutes.
- (3) With the engine not running, use an electronic R-134a leak detector and search for leaks. Because R-134a refrigerant is heavier than air, the leak detector probe should be moved slowly along the bottom side of all refrigerant lines, connector fittings and components.

CAUTION: Never insert a leak detector probe into the outlet for the optional rear overhead A/C unit. Failure to observe this caution could result in damage to the rear blower wheel and/or the leak detector.

- (4) To inspect the evaporator coil for leaks, insert the electronic leak detector probe into the center instrument panel outlet and the floor duct outlet, or near the outside of the rear overhead A/C unit outlet bezel. Set the front or rear blower motor switch to

DIAGNOSIS AND TESTING (Continued)

the lowest speed position, and the mode control switch to the recirculation mode (Max-A/C).

REFRIGERANT SYSTEM SERVICE EQUIPMENT

WARNING: EYE PROTECTION MUST BE WORN WHEN SERVICING AN AIR CONDITIONING REFRIGERANT SYSTEM. TURN OFF (ROTATE CLOCKWISE) ALL VALVES ON THE EQUIPMENT BEING USED, BEFORE CONNECTING TO OR DISCONNECTING FROM THE REFRIGERANT SYSTEM. FAILURE TO OBSERVE THESE WARNINGS MAY RESULT IN PERSONAL INJURY.

When servicing the air conditioning system, a R-134a refrigerant recovery/recycling/charging station that meets SAE Standard J2210 must be used. Contact an automotive service equipment supplier for refrigerant recovery/recycling/charging equipment. Refer to the operating instructions supplied by the equipment manufacturer for the proper care and use of this equipment.

A manifold gauge set may be needed with some recovery/recycling/charging equipment (Fig. 9). The service hoses on the gauge set being used should have manual (turn wheel), or automatic back-flow valves at the service port connector ends. This will prevent refrigerant from being released into the atmosphere.

MANIFOLD GAUGE SET CONNECTIONS

CAUTION: Do not use an R-12 manifold gauge set on an R-134a system. The refrigerants are not compatible and system damage will result.

LOW PRESSURE GAUGE HOSE

The low pressure hose (Blue with Black stripe) attaches to the suction service port. This port is located on the compressor manifold, directly over the suction port of the compressor.

HIGH PRESSURE GAUGE HOSE

The high pressure hose (Red with Black stripe) attaches to the discharge service port. This port is located on the liquid line between the condenser and the evaporator, near the front of the engine compartment.

RECOVERY/RECYCLING/EVACUATION/CHARGING HOSE

The center manifold hose (Yellow, or White, with Black stripe) is used to recover, evacuate, and charge the refrigerant system. When the low or high pressure valves on the manifold gauge set are opened, the refrigerant in the system will escape through this hose.

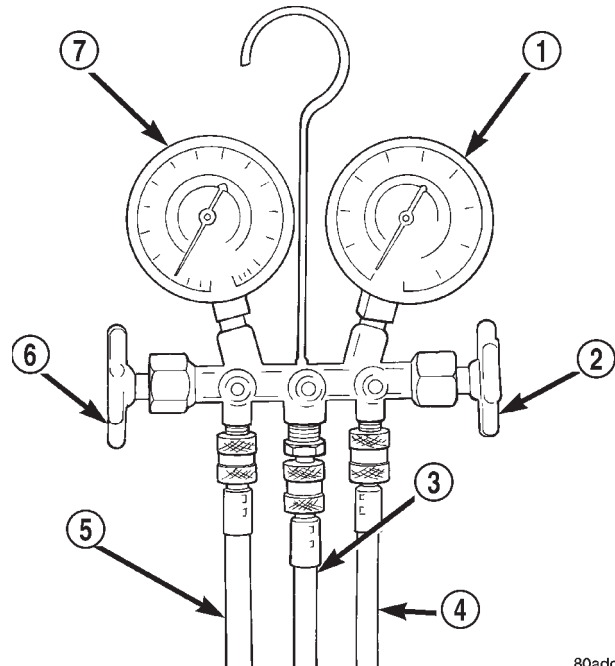

80add30c

Fig. 9 Manifold Gauge Set - Typical

- 1 - HIGH PRESSURE GAUGE
- 2 - VALVE
- 3 - VACUUM/REFRIGERANT HOSE (YELLOW W/BLACK STRIPE)
- 4 - HIGH PRESSURE HOSE (RED W/BLACK STRIPE)
- 5 - LOW PRESSURE HOSE (BLUE W/BLACK STRIPE)
- 6 - VALVE
- 7 - LOW PRESSURE GAUGE

VACUUM SYSTEM

Vacuum control is used to operate the mode doors in the heater-A/C housing. Testing of the heater-A/C mode control switch operation will determine if the vacuum, electrical, and mechanical controls are functioning. However, it is possible that a vacuum control system that operates perfectly at engine idle (high engine vacuum) may not function properly at high engine speeds or loads (low engine vacuum). This can be caused by leaks in the vacuum system, or by a faulty or improperly installed vacuum check valve.

A vacuum system test will help to identify the source of poor vacuum system performance or vacuum system leaks. Before starting this test, stop the engine and make certain that the problem is not a disconnected vacuum supply tube at the engine vacuum source or at the vacuum reservoir.

Use an adjustable vacuum test set (Special Tool C-3707-B) and a suitable vacuum pump to test the heater-A/C vacuum control system. With a finger placed over the end of the vacuum test hose probe (Fig. 10), adjust the bleed valve on the test set gauge to obtain a vacuum of exactly 27 kPa (8 in. Hg.). Release and block the end of the probe several times to verify that the vacuum reading returns to the

DIAGNOSIS AND TESTING (Continued)

exact 27 kPa (8 in. Hg.) setting. Otherwise, a false reading will be obtained during testing.

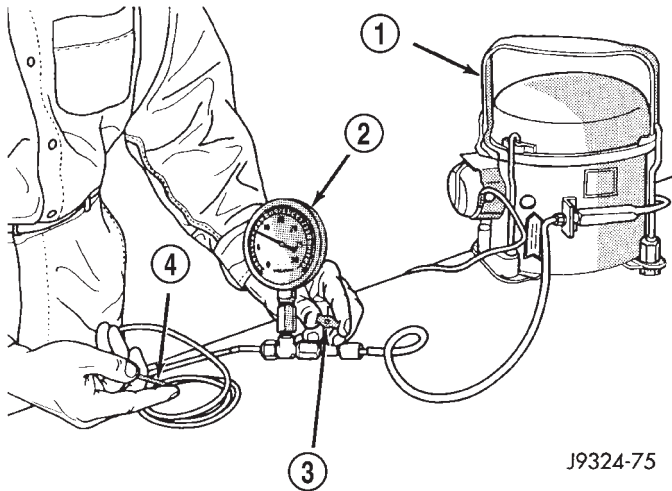

J9324-75

Fig. 10 Adjust Vacuum Test Bleed Valve

- 1 - VACUUM PUMP TOOL C-4289
- 2 - VACUUM TEST SET C-3707
- 3 - BLEED VALVE
- 4 - PROBE

VACUUM CHECK VALVE

(1) Remove the vacuum check valve that is to be tested. The valves are located in the vacuum supply tube (black) at the power brake booster on the left side of the engine compartment, and in the heater and air conditioner vacuum take-out of the vacuum supply tube in the engine compartment. The vacuum check valve must be removed in order to perform the following tests. See Vacuum Check Valve in the Removal and Installation section of this group for the procedures.

(2) Connect the test set vacuum supply hose to the heater-A/C control side of the valve. When connected to this side of the check valve, no vacuum should pass and the test set gauge should return to the 27 kPa (8 in. Hg.) setting. If OK, go to step Step 3. If not OK, replace the faulty valve.

(3) Connect the test set vacuum supply hose to the engine vacuum side of the valve. When connected to this side of the check valve, vacuum should flow through the valve without restriction. If not OK, replace the faulty valve.

HEATER-A/C CONTROLS

(1) Connect the test set vacuum probe to the heater-A/C vacuum supply (black) tube in the engine compartment. Position the test set gauge so that it can be viewed from the passenger compartment.

(2) Place the heater-A/C mode control switch knob in each mode position, one position at a time, and pause after each selection. The test set gauge should

return to the 27 kPa (8 in. Hg.) setting shortly after each selection is made. If not OK, a component or vacuum line in the vacuum circuit of the selected mode has a leak. See Locating Vacuum Leaks in the Diagnosis and Testing section of this group.

CAUTION: Do not use lubricant on the switch ports or in the holes in the plug, as lubricant will ruin the vacuum valve in the switch. A drop of clean water in the connector plug holes will help the connector slide onto the switch ports.

LOCATING VACUUM LEAKS

WARNING: ON VEHICLES EQUIPPED WITH AIR-BAGS, REFER TO GROUP 8M - PASSIVE RESTRAINT SYSTEMS BEFORE ATTEMPTING ANY STEERING WHEEL, STEERING COLUMN, OR INSTRUMENT PANEL COMPONENT DIAGNOSIS OR SERVICE. FAILURE TO TAKE THE PROPER PRECAUTIONS COULD RESULT IN ACCIDENTAL AIR-BAG DEPLOYMENT AND POSSIBLE PERSONAL INJURY.

(1) Disconnect the vacuum harness connector from the back of the heater-A/C mode control switch on the instrument panel.

(2) Connect the test set vacuum hose probe to each port in the vacuum harness connector, one port at a time, and pause after each connection (Fig. 11). The test set gauge should return to the 27 kPa (8 in. Hg.) setting shortly after each connection is made. If OK, replace the faulty heater-A/C control. If not OK, go to Step 3.

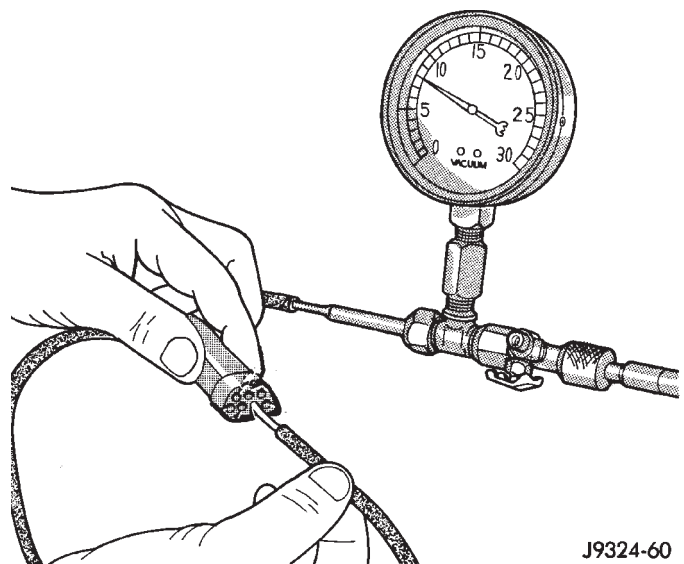

J9324-60

Fig. 11 Vacuum Circuit Test

DIAGNOSIS AND TESTING (Continued)

(3) Determine the vacuum line color of the vacuum circuit that is leaking. To determine the vacuum line colors, see the Vacuum Circuits chart (Fig. 12).

(4) Disconnect and plug the vacuum line from the component (fitting, actuator, valve, switch, or reservoir) on the other end of the leaking circuit. Instrument panel disassembly or removal may be necessary to gain access to some components. See the Removal and Installation section of this group for more information.

(5) Connect the test set hose or probe to the open end of the leaking circuit. The test set gauge should return to the 27 kPa (8 in. Hg.) setting shortly after

each connection is made. If OK, replace the faulty disconnected component. If not OK, go to Step 6.

(6) To locate a leak in a vacuum line, leave one end of the line plugged and connect the test set hose or probe to the other end of the line. Run your fingers slowly along the line while watching the test set gauge. The vacuum reading will fluctuate when your fingers contact the source of the leak. To repair the vacuum line, cut out the leaking section of the line. Then, insert the loose ends of the line into a suitable length of 3 millimeter (0.125 inch) inside diameter rubber hose.

DIAGNOSIS AND TESTING (Continued)

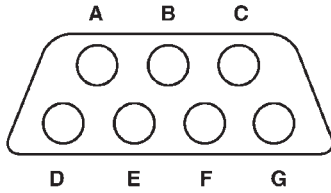

VACUUM CIRCUIT LEGEND		
I.D.	FUNCTION	COLOR
A	Recirculation Actuator (Door Closed)	Light Green
B	Floor-Defrost Actuator (Mid Position)	Yellow
C	Panel-Defrost Actuator (Full Position)	Brown
D	Floor-Defrost Actuator (Full Position)	Blue
E	Vacuum Supply (Reservoir)	Black
F	Panel-Defrost Actuator (Mid Position)	Red
G	Recirculation Actuator (Door Open)	Dark Green

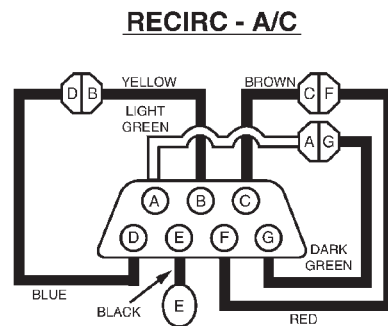
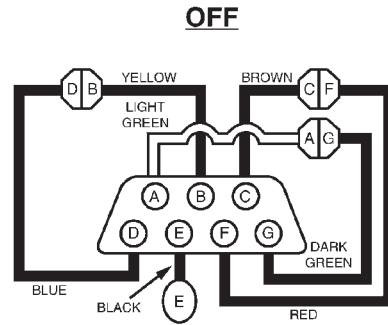

PANEL - A/C

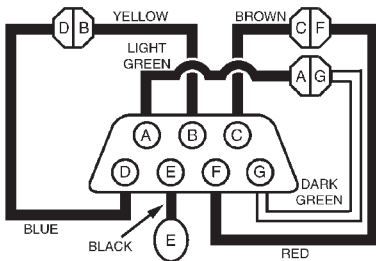

BI-LEVEL - A/C

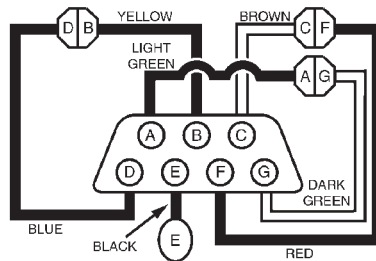

PANEL

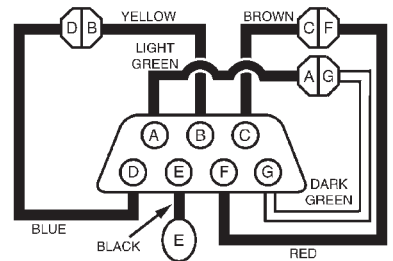

HEAT

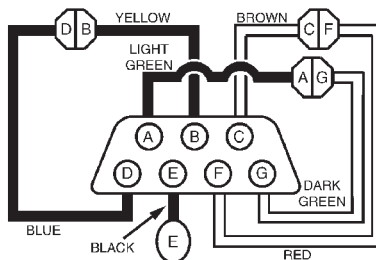

MIX

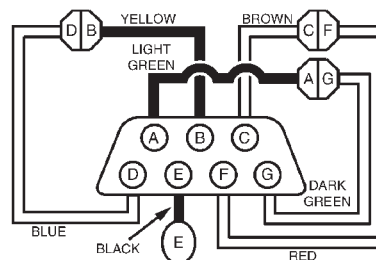

DEFROST

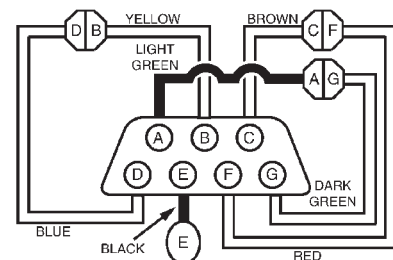

Fig. 12 Vacuum Circuits

SERVICE PROCEDURES

REFRIGERANT OIL LEVEL

When an air conditioning system is assembled at the factory, all components except the compressor are refrigerant oil free. After the refrigerant system has been charged and operated, the refrigerant oil in the compressor is dispersed throughout the refrigerant system. The evaporator, filter-drier, condenser, and compressor will each retain a significant amount of the needed refrigerant oil.

It is important to have the correct amount of oil in the refrigerant system. This ensures proper lubrication of the compressor. Too little oil will result in damage to the compressor. Too much oil will reduce the cooling capacity of the air conditioning system.

It will not be necessary to check the oil level in the compressor or to add oil, unless there has been an oil loss. An oil loss may occur due to a rupture or leak from a refrigerant line, a connector fitting, a component, or a component seal. If a leak occurs, add 30 milliliters (1 fluid ounce) of refrigerant oil to the refrigerant system after the repair has been made. Refrigerant oil loss will be evident at the leak point by the presence of a wet, shiny surface around the leak.

Refrigerant oil must be added when a filter-drier, evaporator coil, or condenser are replaced. See the Refrigerant Oil Capacities chart. When a compressor is replaced, the refrigerant oil must be drained from the old compressor and measured. Drain all of the refrigerant oil from the new compressor, then fill the new compressor with the same amount of refrigerant oil that was drained out of the old compressor.

Refrigerant Oil Capacities		
Component	ml	fl oz
A/C System 4.7 L (Front Only)	165	5.5
A/C System 4.7 L (Front & Rear)	240	8
A/C System 5.9L (Front Only)	180	6.1
A/C System 5.9L (Front & Rear)	240	8
Filter-Drier	30	1
Condenser	30	1
Evaporator (Front)	60	2
Evaporator (Rear)	30	1
Compressor	drain and measure the oil from the old compressor - see text.	

REFRIGERANT RECOVERY

WARNING: REVIEW THE WARNINGS AND CAUTIONS IN THE GENERAL INFORMATION SECTION NEAR THE FRONT OF THIS GROUP BEFORE RECOVERING REFRIGERANT.

A R-134a refrigerant recovery/recycling/charging station that meets SAE Standard J2210 must be used to recover the refrigerant from an R-134a refrigerant system. Refer to the operating instructions supplied by the equipment manufacturer for the proper care and use of this equipment.

REFRIGERANT SYSTEM CHARGE

WARNING: REVIEW THE WARNINGS AND CAUTIONS IN THE GENERAL INFORMATION SECTION NEAR THE FRONT OF THIS GROUP BEFORE CHARGING THE REFRIGERANT SYSTEM.

After the refrigerant system has been tested for leaks and evacuated, a refrigerant charge can be injected into the system. See Refrigerant Charge Capacity in the Service Procedures section of this group for the proper amount of the refrigerant charge.

A R-134a refrigerant recovery/recycling/charging station that meets SAE Standard J2210 must be used to charge the refrigerant system with R-134a refrigerant. Refer to the operating instructions supplied by the equipment manufacturer for the proper care and use of this equipment.

REFRIGERANT CHARGE CAPACITY

The R-134a refrigerant system charge capacity for this vehicle is: Single Unit: 0.793 kilograms (28 ounces), Dual Unit: 0.907 kilograms (32 ounces).

REFRIGERANT SYSTEM EVACUATE

WARNING: REVIEW THE WARNINGS AND CAUTIONS IN THE GENERAL INFORMATION SECTION NEAR THE FRONT OF THIS GROUP BEFORE EVACUATING THE SYSTEM.

If the refrigerant system has been open to the atmosphere, it must be evacuated before the system can be charged. If moisture and air enters the system and becomes mixed with the refrigerant, the compressor head pressure will rise above acceptable operating levels. This will reduce the performance of the air conditioner and damage the compressor. Evacuating the refrigerant system will remove the air and boil the moisture out of the system at near room temperature. To evacuate the refrigerant system, use the following procedure:

SERVICE PROCEDURES (Continued)

(1) Connect a R-134a refrigerant recovery/recycling/charging station that meets SAE Standard J2210 and a manifold gauge set to the refrigerant system of the vehicle.

(2) Open the low and high side valves and start the charging station vacuum pump. When the suction gauge reads 88 kPa (26 in. Hg.) vacuum or greater, close all of the valves and turn off the vacuum pump.

(a) If the refrigerant system fails to reach the specified vacuum, the system has a leak that must be corrected. See Refrigerant System Leaks in the Diagnosis and Testing section of this group for the procedures.

(b) If the refrigerant system maintains the specified vacuum for five minutes, restart the vacuum pump, open the suction and discharge valves and evacuate the system for an additional ten minutes.

(3) Close all of the valves, and turn off the charging station vacuum pump.

(4) The refrigerant system is now ready to be charged with R-134a refrigerant. See Refrigerant System Charge in the Service Procedures section of this group.

REMOVAL AND INSTALLATION

SERVICE WARNINGS AND PRECAUTIONS

WARNING:

- **THE AIR CONDITIONING SYSTEM CONTAINS REFRIGERANT UNDER HIGH PRESSURE. SEVERE PERSONAL INJURY MAY RESULT FROM IMPROPER SERVICE PROCEDURES. REPAIRS SHOULD ONLY BE PERFORMED BY QUALIFIED SERVICE PERSONNEL.**

- **AVOID BREATHING THE REFRIGERANT AND REFRIGERANT OIL VAPOR OR MIST. EXPOSURE MAY IRRITATE THE EYES, NOSE, AND/OR THROAT. WEAR EYE PROTECTION WHEN SERVICING THE AIR CONDITIONING REFRIGERANT SYSTEM. SERIOUS EYE INJURY CAN RESULT FROM DIRECT CONTACT WITH THE REFRIGERANT. IF EYE CONTACT OCCURS, SEEK MEDICAL ATTENTION IMMEDIATELY.**

- **DO NOT EXPOSE THE REFRIGERANT TO OPEN FLAME. POISONOUS GAS IS CREATED WHEN REFRIGERANT IS BURNED. AN ELECTRONIC LEAK DETECTOR IS RECOMMENDED.**

- **IF ACCIDENTAL SYSTEM DISCHARGE OCCURS, VENTILATE THE WORK AREA BEFORE RESUMING SERVICE. LARGE AMOUNTS OF REFRIGERANT RELEASED IN A CLOSED WORK AREA WILL DISPLACE THE OXYGEN AND CAUSE SUFFOCATION.**

- **THE EVAPORATION RATE OF R-134a REFRIGERANT AT AVERAGE TEMPERATURE AND ALTITUDE IS EXTREMELY HIGH. AS A RESULT, ANYTHING THAT COMES IN CONTACT WITH THE REFRIGERANT WILL FREEZE. ALWAYS PROTECT THE SKIN OR DELICATE OBJECTS FROM DIRECT CONTACT WITH THE REFRIGERANT.**

- **THE R-134a SERVICE EQUIPMENT OR THE VEHICLE REFRIGERANT SYSTEM SHOULD NOT BE PRESSURE TESTED OR LEAK TESTED WITH COMPRESSED AIR. SOME MIXTURES OF AIR AND R-134a HAVE BEEN SHOWN TO BE COMBUSTIBLE AT ELEVATED PRESSURES. THESE MIXTURES ARE POTENTIALLY DANGEROUS, AND MAY RESULT IN FIRE OR EXPLOSION CAUSING INJURY OR PROPERTY DAMAGE.**

REMOVAL AND INSTALLATION (Continued)

CAUTION:

- Liquid refrigerant is corrosive to metal surfaces. Follow the operating instructions supplied with the service equipment being used.
- Never add R-12 to a refrigerant system designed to use R-134a. Damage to the system will result.
- R-12 refrigerant oil must not be mixed with R-134a refrigerant oil. They are not compatible.
- Do not use R-12 equipment or parts on the R-134a system. Damage to the system will result.
- Do not overcharge the refrigerant system. This will cause excessive compressor head pressure and can cause noise and system failure.
- Recover the refrigerant before opening any fitting or connection. Open the fittings with caution, even after the system has been discharged. Never open or loosen a connection before recovering the refrigerant.
- Do not remove the secondary retention clip from any spring-lock coupler connection while the refrigerant system is under pressure. Recover the refrigerant before removing the secondary retention clip. Open the fittings with caution, even after the system has been discharged. Never open or loosen a connection before recovering the refrigerant.
- The refrigerant system must always be evacuated before charging.
- Do not open the refrigerant system or uncap a replacement component until you are ready to service the system. This will prevent contamination in the system.
- Before disconnecting a component, clean the outside of the fittings thoroughly to prevent contamination from entering the refrigerant system.
- Immediately after disconnecting a component from the refrigerant system, seal the open fittings with a cap or plug.
- Before connecting an open refrigerant fitting, always install a new seal or gasket. Coat the fitting and seal with clean refrigerant oil before connecting.
- Do not remove the sealing caps from a replacement component until it is to be installed.
- When installing a refrigerant line, avoid sharp bends that may restrict refrigerant flow. Position the refrigerant lines away from exhaust system components or any sharp edges, which may damage the line.
- Tighten refrigerant fittings only to the specified torque. The aluminum fittings used in the refrigerant system will not tolerate overtightening.
- Refrigerant oil will absorb moisture from the atmosphere if left uncapped. Do not open a container of refrigerant oil until you are ready to use it. Replace the cap on the oil container immediately

after using. Store refrigerant oil only in a clean, airtight, and moisture-free container.

- Keep service tools and the work area clean. Contamination of the refrigerant system through careless work habits must be avoided.

COOLING SYSTEM REQUIREMENTS

To maintain the performance level of the heating-air conditioning system, the engine cooling system must be properly maintained. The use of a bug screen is not recommended. Any obstructions in front of the radiator or condenser will reduce the performance of the air conditioning and engine cooling systems.

The engine cooling system includes the heater core and the heater hoses. Refer to Group 7 - Cooling System for more information before the opening of, or attempting any service to the engine cooling system.

REFRIGERANT HOSES/LINES/TUBES PRECAUTIONS

Kinks or sharp bends in the refrigerant plumbing will reduce the capacity of the entire system. High pressures are produced in the system when it is operating. Extreme care must be exercised to make sure that all refrigerant system connections are pressure tight.

A good rule for the flexible hose refrigerant lines is to keep the radius of all bends at least ten times the diameter of the hose. Sharp bends will reduce the flow of refrigerant. The flexible hose lines should be routed so they are at least 80 millimeters (3 inches) from the exhaust manifold. It is a good practice to inspect all flexible refrigerant system hose lines at least once a year to make sure they are in good condition and properly routed.

There are two types of refrigerant fittings:

- All fittings with O-rings need to be coated with refrigerant oil before installation. Use only O-rings that are the correct size and approved for use with R-134a refrigerant. Failure to do so may result in a leak.

- Unified plumbing connections with gaskets cannot be serviced with O-rings. The gaskets are not reusable and new gaskets do not require lubrication before installing.

Using the proper tools when making a refrigerant plumbing connection is very important. Improper tools or improper use of the tools can damage the refrigerant fittings.

The refrigerant must be recovered completely from the system before opening any fitting or connection. Open the fittings with caution, even after the refrigerant has been recovered. If any pressure is noticed

REMOVAL AND INSTALLATION (Continued)

as a fitting is loosened, tighten the fitting and recover the refrigerant from the system again.

Do not discharge refrigerant into the atmosphere. Use an R-134a refrigerant recovery/recycling device that meets SAE Standard J2210.

The refrigerant system will remain chemically stable as long as pure, moisture-free R-134a refrigerant and refrigerant oil is used. Dirt, moisture, or air can upset this chemical stability. Operational troubles or serious damage can occur if foreign material is present in the refrigerant system.

When it is necessary to open the refrigerant system, have everything needed to service the system ready. The refrigerant system should not be left open to the atmosphere any longer than necessary. Cap or plug all lines and fittings as soon as they are opened to prevent the entrance of dirt and moisture. All lines and components in parts stock should be capped or sealed until they are to be installed.

All tools, including the refrigerant recycling equipment, the manifold gauge set, and test hoses should be kept clean and dry. All tools and equipment must be designed for R-134a refrigerant.

B-PILLAR REFRIGERANT LINE

The B-pillar refrigerant lines are used only on models with the optional rear overhead A/C unit. Both the B-pillar suction line and the B-pillar liquid line are available for separate service replacement. Each line may be removed independently from the vehicle for service.

Any kinks or sharp bends in the refrigerant plumbing will reduce the capacity of the entire air conditioning system. Kinks and sharp bends reduce the flow of refrigerant in the system. High pressures are produced in the refrigerant system when the air conditioning compressor is operating. Extreme care must be exercised to make sure that each of the refrigerant system connections is pressure-tight and leak free.

WARNING: REVIEW THE WARNINGS AND CAUTIONS IN THE GENERAL INFORMATION SECTION NEAR THE FRONT OF THIS GROUP BEFORE PERFORMING THE FOLLOWING OPERATION.

REMOVAL

- (1) Disconnect and isolate the battery negative cable.
- (2) Recover the refrigerant from the refrigerant system. See Refrigerant Recovery in the Service Procedures section of this group.
- (3) Raise and support the vehicle.
- (4) From under the vehicle, disconnect the underbody liquid line refrigerant line coupler at the B-pillar liquid line and the underbody suction line

refrigerant line coupler at the B-pillar suction line. See Refrigerant Line Coupler in the Removal and Installation section of this group for the procedures. Install plugs in, or tape over all of the opened refrigerant line fittings.

- (5) Lower the vehicle.
- (6) Remove the headliner from the passenger compartment of the vehicle. Refer to Group 23 - Body for the procedures. The B-pillar upper and lower trim must be removed.
- (7) From the passenger compartment, remove the fasteners that secure the block fittings at the top of the B-pillar refrigerant lines to the rear overhead A/C unit (nut from stud - liquid line) (nut and bolt - suction line), and disengage the fittings (Fig. 13). Install plugs in, or tape over all of the opened refrigerant line fittings.

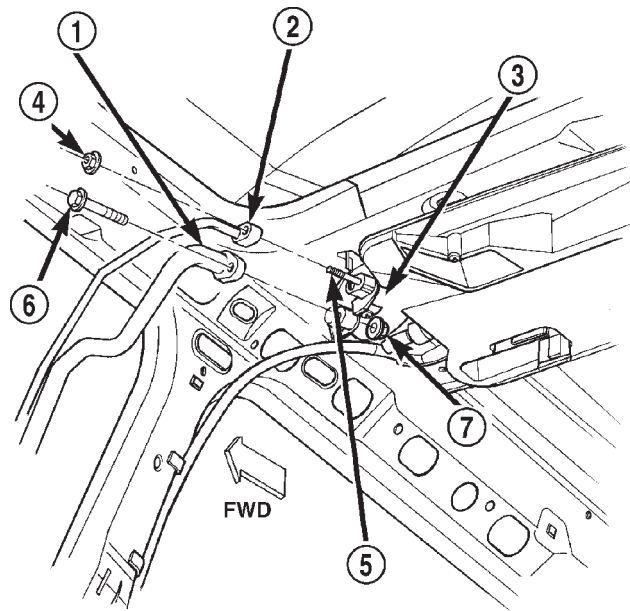

Fig. 13 Rear Overhead A/C Unit Refrigerant Line Remove/Install

80b3c5eb

- 1 - B-PILLAR SUCTION LINE
- 2 - B-PILLAR LIQUID LINE
- 3 - OVERHEAD AIR CONDITIONING UNIT
- 4 - NUT
- 5 - STUD
- 6 - BOLT
- 7 - NUT

- (8) Remove the two screws that secure the B-pillar refrigerant line clamps to the B-pillar (Fig. 14).
- (9) Remove the two screws that secure the B-pillar refrigerant line clamp and seal unit to the floor panel at the base of the B-pillar.
- (10) Tilt the top of the B-pillar refrigerant line unit towards the front of the vehicle far enough so that the lower end of the unit can be lifted out through the hole in the floor panel.

REMOVAL AND INSTALLATION (Continued)

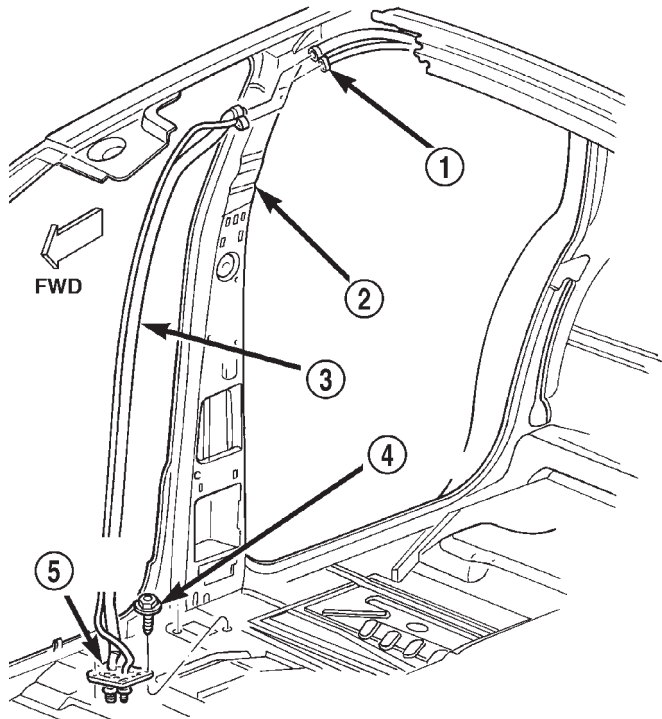

80b9a4c5

Fig. 14 B-Pillar Refrigerant Lines Remove/Install

- 1 - OVERHEAD AIR CONDITIONING UNIT
- 2 - B-PILLAR
- 3 - B-PILLAR REFRIGERANT LINE
- 4 - SCREW
- 5 - CLAMP AND SEAL

(11) Remove the B-pillar refrigerant line unit from the passenger compartment.

NOTE: If either the liquid line or the suction line is removed from the B-pillar refrigerant line clamp and seal, the clamp and seal will be damaged. Replace the clamp and seal with a new unit.

INSTALLATION

(1) Position the B-pillar refrigerant line unit in the passenger compartment with the lower end of the lines inserted through the hole in the floor panel at the base of the B-pillar, and the top end of the lines oriented towards the front of the vehicle.

(2) Tilt the top of the B-pillar refrigerant line unit up into position near the rear overhead A/C unit.

(3) Remove the tape or plugs from block fittings at the top of the B-pillar refrigerant line unit, and from the fittings on the rear overhead A/C unit. Install the B-pillar refrigerant line block fittings over the one stud on the rear overhead A/C unit. Install the bolt holding the suction line, and secure the connections with the mounting nuts. Tighten the mounting nuts to 11.3 N·m (100 in. lbs.).

(4) Position the B-pillar refrigerant line clamp and seal over the hole in the floor panel and secure it with two screws. Tighten the mounting screws to 2.2 N·m (20 in. lbs.).

(5) Position the B-pillar refrigerant line over the mounting holes in the inner B-pillar and secure with a screw. Tighten the mounting screw to 2.2 N·m (20 in. lbs.).

(6) Reinstall the headliner in the passenger compartment. Refer to Group 23 - Body for the procedures. Reinstall the lower B-pillar trim panel, upper trim panel, and seat belt bolt adjuster.

(7) Raise and support the vehicle.

(8) From under the vehicle, remove the tape or plugs from the refrigerant line fittings at the underbody and B-pillar liquid lines, and from the underbody and B-pillar suction lines. Connect the underbody refrigerant lines to the B-pillar refrigerant lines. See Refrigerant Line Coupler in the Removal and Installation section of this group for the procedures.

(9) Connect the battery negative cable.

(10) Evacuate the refrigerant system. See Refrigerant System Evacuate in the Service Procedures section of this group.

(11) Charge the refrigerant system. See Refrigerant System Charge in the Service Procedures section of this group.

BLOWER MOTOR

WARNING: ON VEHICLES EQUIPPED WITH AIRBAGS, REFER TO GROUP 8M - PASSIVE RESTRAINT SYSTEMS BEFORE ATTEMPTING ANY STEERING WHEEL, STEERING COLUMN, OR INSTRUMENT PANEL COMPONENT DIAGNOSIS OR SERVICE. FAILURE TO TAKE THE PROPER PRECAUTIONS COULD RESULT IN ACCIDENTAL AIRBAG DEPLOYMENT AND POSSIBLE PERSONAL INJURY.

FRONT**REMOVAL**

(1) Remove and disassemble the heater-A/C housing. See Heater-A/C Housing in the Removal and Installation section of this group for the procedures.

(2) Remove the three screws that secure the blower motor, air spoiler, and blower wheel assembly to the heater-A/C housing (Fig. 15).

(3) Pull the blower motor and wheel assembly out of the passenger compartment side of the heater-A/C housing while feeding the blower motor wire harness, grommet and connector through the hole on the dash panel side of the housing.

REMOVAL AND INSTALLATION (Continued)

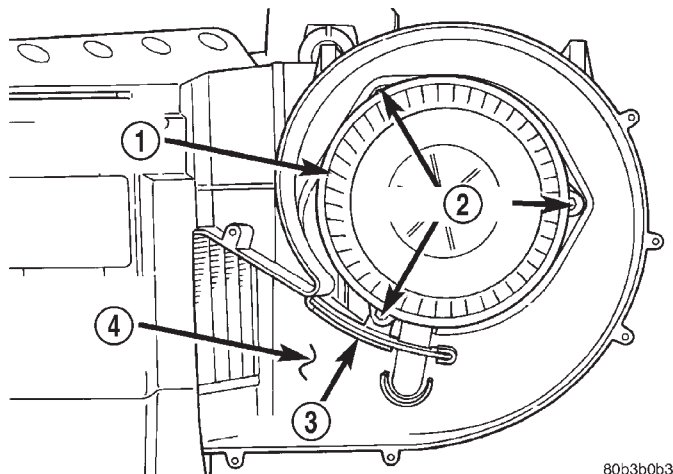

Fig. 15 Blower Motor Remove/Install

80c3b0b3

- 1 - BLOWER WHEEL
- 2 - SCREWS
- 3 - AIR SPOILER
- 4 - BLOWER MOTOR HOUSING

(4) Remove the blower wheel retainer clip and remove the wheel from the blower motor shaft (Fig. 16).

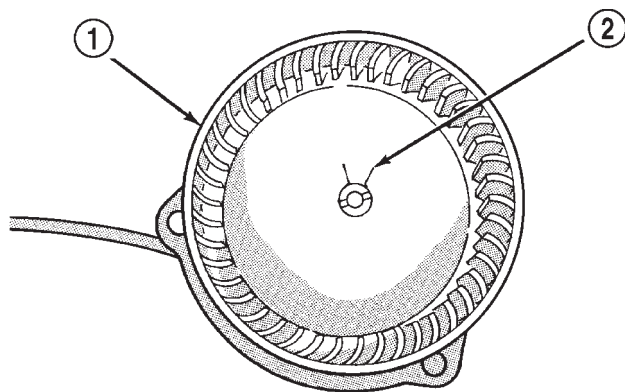

Fig. 16 Blower Motor Wheel Remove/Install

J9324-92

- 1 - BLOWER MOTOR WHEEL
- 2 - RETAINER CLIP

INSTALLATION

(1) Press the blower wheel hub onto the blower motor shaft. Be sure the flat on the blower motor shaft is indexed to the flat on the inside of the blower wheel hub.

(2) Install the retainer clip over the blower wheel hub. The ears of the retainer clip must be indexed over the flats on the blower motor shaft and blower wheel hub.

(3) Place the blower motor, air spoiler, and wheel assembly inside the heater-A/C housing and feed the blower motor wire harness connector through the grommet hole in the dash panel side of the housing.

(4) Pull the blower motor wiring through the hole from the dash panel side of the heater-A/C housing until the grommet is seated, while positioning the blower motor and blower wheel assembly inside the housing.

(5) Install the three screws that secure the blower motor, air spoiler, and wheel assembly to the heater-A/C housing. Tighten the screws to 2.2 N-m (20 in. lbs.).

(6) Assemble and install the heater-A/C housing. See Heater-A/C Housing in the Removal and Installation section of this group for the procedures.

REAR

The rear blower motor is used only on models with the optional rear overhead A/C unit. Because the rear blower motor and wheel are factory balanced units, the rear blower motor, wheel, housing and mounting hardware are serviced only as a complete unit.

REMOVAL

(1) Disconnect and isolate the battery negative cable.

(2) Remove the headliner from the passenger compartment of the vehicle. Refer to Group 23 - Body for the procedures.

(3) Disconnect the B-pillar drain hoses from the wye fittings on each side of the rear overhead A/C unit (Fig. 17).

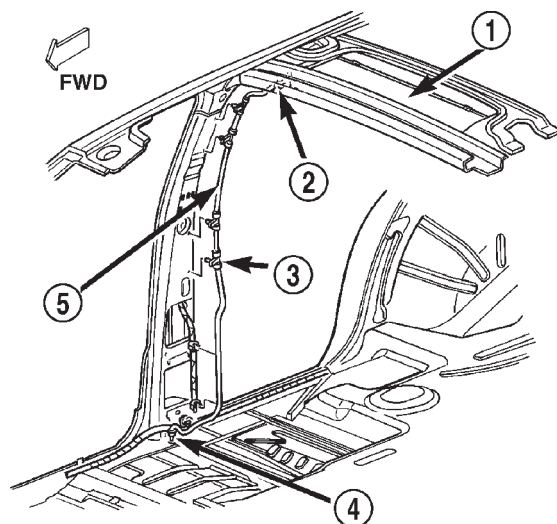

Fig. 17 Rear Overhead A/C Drain Hose Remove/Install

80b2b519

- 1 - REAR OVERHEAD A/C UNIT
- 2 - WYE FITTING
- 3 - CLIP
- 4 - GROMMET
- 5 - DRAIN HOSE

REMOVAL AND INSTALLATION (Continued)

(4) Remove the nine screws that secure the lower housing cover to the rear overhead A/C unit.

(5) Release the lower housing cover snap retainer near the center of the outlet side (rear) of the rear overhead A/C unit (Fig. 18).

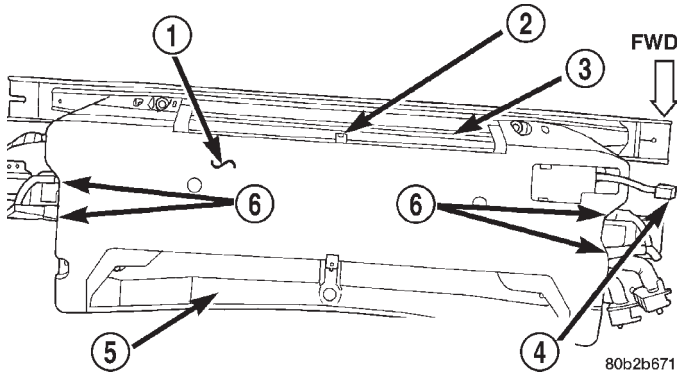

Fig. 18 Rear Overhead A/C Unit Lower Housing Cover Remove/Install

- 1 - REAR OVERHEAD A/C UNIT LOWER HOUSING COVER
- 2 - SNAP RETAINER
- 3 - OUTLET SIDE
- 4 - BLOWER MOTOR SWITCH WIRE HARNESS CONNECTOR
- 5 - INLET SIDE
- 6 - DRAIN HOSES

(6) Feed the rear blower motor switch wire harness and connector through the hole in the right end of the rear overhead A/C unit lower housing cover while removing the cover from the unit.

(7) Disengage the rear blower motor wire harness connector retainer from the mounting hole in the left rear corner of the rear overhead A/C unit upper housing cover.

(8) Unplug the rear blower motor wire harness connector (Fig. 19).

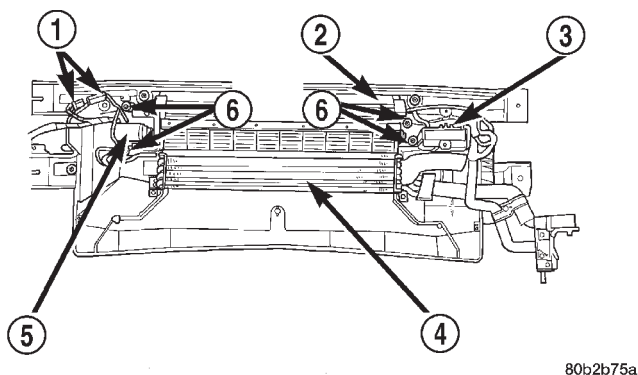

Fig. 19 Rear Blower Motor and Wheel Remove/Install

- 1 - WIRE HARNESS CONNECTORS
- 2 - BLOWER WHEEL AND HOUSING
- 3 - RESISTOR
- 4 - EVAPORATOR COIL
- 5 - BLOWER MOTOR
- 6 - SCREWS

(9) Remove the four screws that secure the rear blower motor, wheel and housing unit to the rear overhead A/C unit upper housing cover.

(10) Lower the rear blower motor, wheel and housing unit far enough to access and disengage the rear overhead A/C unit wire harness from each end of the blower housing.

(11) Remove the rear blower motor, wheel and housing unit from the rear overhead A/C unit.

INSTALLATION

(1) Position the rear blower motor, wheel and housing unit to the rear overhead A/C unit, and start the four mounting screws to hold it in position.

(2) Engage the rear overhead A/C unit wire harness in the routing holes on each end of the blower housing.

(3) Finish installing the four rear blower motor, wheel and housing unit mounting screws. Tighten the mounting screws to 3 N·m (27 in. lbs.).

(4) Plug in the rear blower motor wire harness connector.

(5) Engage the rear blower motor wire harness connector retainer in the mounting hole in the left rear corner of the rear overhead A/C unit upper housing cover.

(6) Feed the rear blower motor switch wire harness and connector through the hole in the right end of the rear overhead A/C unit lower housing cover while positioning the cover to the unit.

(7) Be certain that the lower housing cover snap retainer near the center of the outlet side (rear) of the rear overhead A/C unit is engaged.

(8) Install the nine screws that secure the lower housing cover to the rear overhead A/C unit. Tighten the mounting screws to 2.2 N·m (20 in. lbs.).

(9) Connect the B-pillar drain hoses to the wye fittings on each side of the rear overhead A/C unit.

(10) Reinstall the headliner to the passenger compartment of the vehicle. Refer to Group 23 - Body for the procedures.

(11) Connect the battery negative cable.

BLOWER MOTOR RELAY

REMOVAL

The blower motor relay (Voltage Reduction Relay or VRR) is mounted with a single screw directly to the instrument panel's structural plastic inside the glove box opening, next to the left-side energy-absorbing bracket (Fig. 20).

(1) Disconnect and isolate the battery negative cable.

(2) Roll down the glove box as described in the Glove Box section of Instrument Panel Systems.

REMOVAL AND INSTALLATION (Continued)

(3) Using a short or 90 degree screwdriver, remove the screw that secures the blower motor relay (VRR) to the steel clip in the instrument panel plastic flange.

(4) Maneuver the VRR into the glove box opening far enough for access, and disengage the wiring harness from the relay.

(5) Remove the relay through the glove box opening.

INSTALLATION

(1) Position the relay into the instrument panel inside the glove box opening.

(2) Align the VRR with the connector and engage the wiring harness to the relay.

(3) Align the relay with the steel clip in the instrument panel, and insert and tighten the single screw to 2.2 N·m (20 in. lbs.).

(4) Roll up the glove box as described in the Glove Box Installation section of Instrument Panel Systems.

(5) Reconnect the battery negative cable.

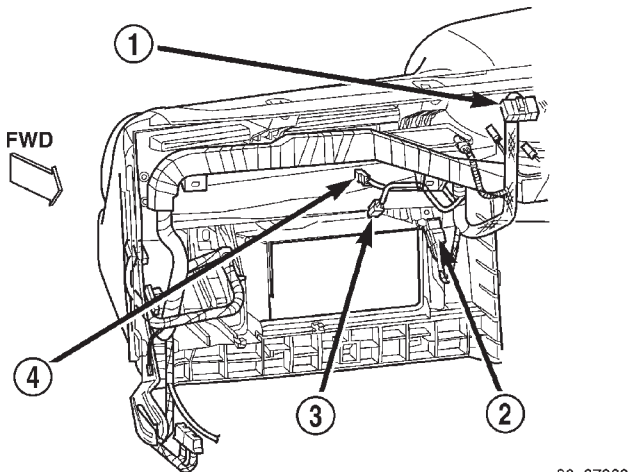

Fig. 20 Blower Motor Relay (VRR) Location

- 1 - BLOWER MOTOR RESISTOR CONNECTOR
- 2 - BLOWER MOTOR RELAY
- 3 - BLOWER MOTOR CONNECTOR
- 4 - GLOVE BOX LAMP CONNECTOR

BLOWER MOTOR RESISTOR

FRONT

REMOVAL

(1) Disconnect and isolate the battery negative cable.

(2) Remove the cowl plenum cover/grille panel from the cowl top. See Vacuum Reservoir in the Removal and Installation section of this group for the procedures.

(3) Reach through the cowl plenum access hole (Fig. 21) to remove the two hex screws that secure

the front blower motor resistor to the cowl plenum panel.

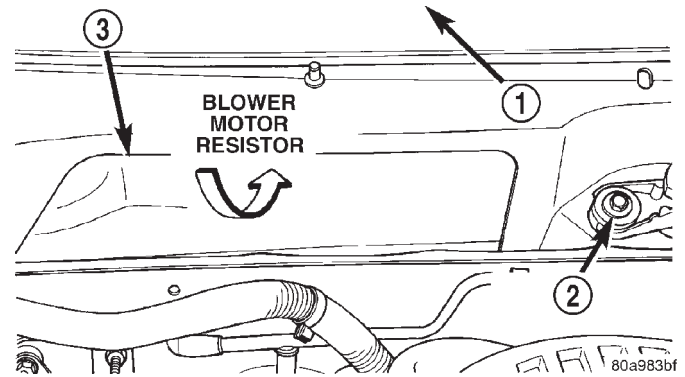

Fig. 21 Blower Motor Resistor Remove/Install

- 1 - WINDSHIELD
- 2 - RIGHT WIPER PIVOT
- 3 - COWL PLENUM ACCESS HOLE

(4) Pull the front blower motor resistor and its wire harness out of the plenum panel and through the cowl plenum access hole far enough to access the wire harness connector.

(5) Unplug the front blower motor resistor from the wire harness connector.

(6) Remove the front blower motor resistor from the cowl plenum.

INSTALLATION

(1) Plug the front blower motor resistor into the wire harness connector.

(2) Install the front blower motor resistor to the cowl plenum panel by feeding the resistor and wire harness back through the cowl plenum access hole.

(3) Install and tighten the two screws that secure the front blower motor resistor to the cowl plenum panel. Tighten the mounting screws to 2.2 N·m (20 in. lbs.).

(4) Reinstall the cowl plenum cover/grille panel to the cowl top. See Vacuum Reservoir in the Removal and Installation section of this group for the procedures.

(5) Connect the battery negative cable.

REAR

The rear blower motor resistor is used only on models with the optional rear overhead A/C unit.

REMOVAL

(1) Disconnect and isolate the battery negative cable.

(2) Remove the headliner from the passenger compartment of the vehicle. Refer to Group 23 - Body for the procedures.

REMOVAL AND INSTALLATION (Continued)

(3) Disconnect the B-pillar drain hoses from the wye fittings on each side of the rear overhead A/C unit (Fig. 22).

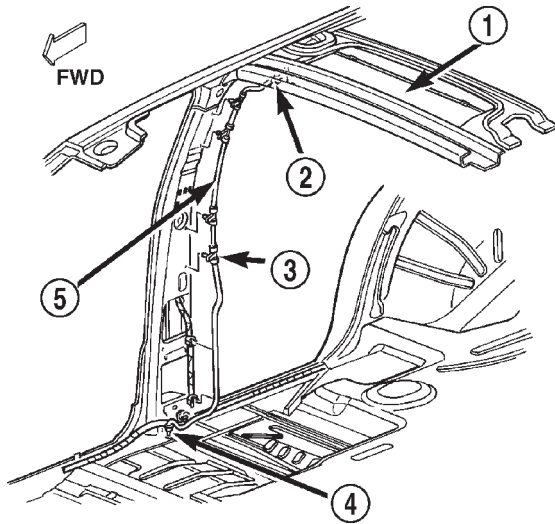

80b2b519

Fig. 22 Rear Overhead A/C Drain Hose Remove/Install

- 1 - REAR OVERHEAD A/C UNIT
- 2 - WYE FITTING
- 3 - CLIP
- 4 - GROMMET
- 5 - DRAIN HOSE

(4) Remove the nine screws that secure the lower housing cover to the rear overhead A/C unit.

(5) Release the lower housing cover snap retainer near the center of the outlet side (rear) of the rear overhead A/C unit (Fig. 23).

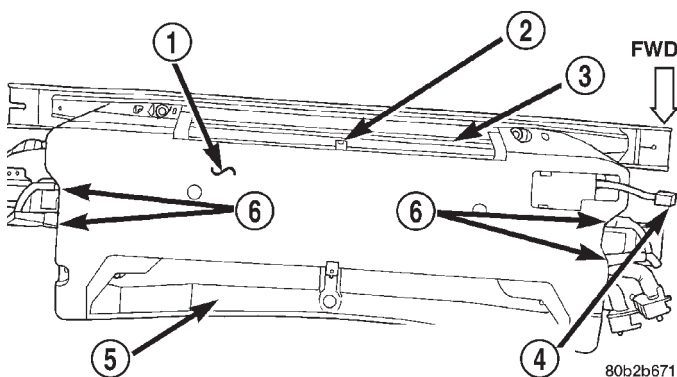

80b2b671

Fig. 23 Rear Overhead A/C Unit Lower Housing Cover Remove/Install

- 1 - REAR OVERHEAD A/C UNIT LOWER HOUSING COVER
- 2 - SNAP RETAINER
- 3 - OUTLET SIDE
- 4 - BLOWER MOTOR SWITCH WIRE HARNESS CONNECTOR
- 5 - INLET SIDE
- 6 - DRAIN HOSES

(6) Feed the rear blower motor switch wire harness and connector through the hole in the right end of the rear overhead A/C unit lower housing cover while removing the cover from the unit.

(7) Disengage the rear blower motor resistor wire harness connector retainer from the mounting hole in the right rear corner of the rear overhead A/C unit upper housing cover (Fig. 24).

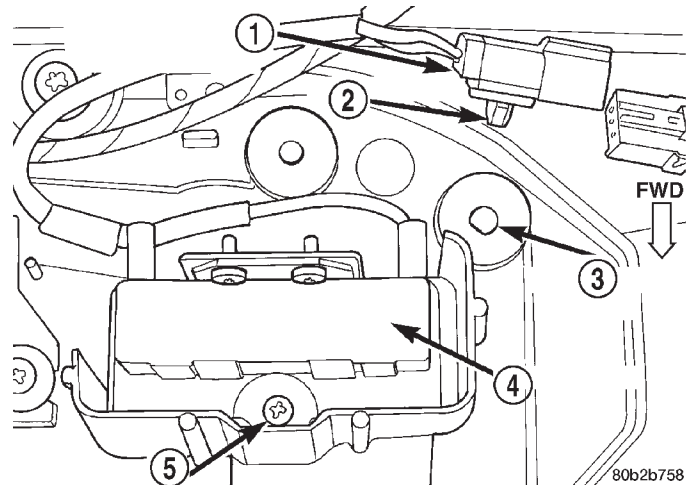

80b2b758

Fig. 24 Rear Blower Motor Resistor Remove/Install

- 1 - WIRE HARNESS CONNECTOR
- 2 - RETAINER
- 3 - MOUNTING HOLE
- 4 - RESISTOR
- 5 - SCREW

(8) Unplug the rear blower motor resistor wire harness connector.

(9) Remove the screw that secures the rear blower motor resistor bracket to the rear overhead A/C unit upper housing cover.

(10) Remove the rear blower motor resistor and bracket as a unit from the rear overhead A/C unit.

INSTALLATION

(1) Position the rear blower motor resistor and bracket in the right rear corner of the rear overhead A/C unit upper housing cover and secure it with the mounting screw. Tighten the mounting screw to 2.2 N·m (20 in. lbs.).

(2) Plug in the rear blower motor resistor wire harness connector.

(3) Engage the rear blower motor resistor wire harness connector retainer to the mounting hole in the right rear corner of the rear overhead A/C unit upper housing cover.

(4) Feed the rear blower motor switch wire harness and connector through the hole in the right end of the rear overhead A/C unit lower housing cover while positioning the cover to the unit.

REMOVAL AND INSTALLATION (Continued)

- (5) Be certain that the lower housing cover snap retainer near the center of the outlet side (rear) of the rear overhead A/C unit is engaged.
- (6) Install the nine screws that secure the lower housing cover to the rear overhead A/C unit. Tighten the mounting screws to 2.2 N·m (20 in. lbs.).
- (7) Connect the B-pillar drain hoses to the wye fittings on each side of the rear overhead A/C unit.
- (8) Reinstall the headliner to the passenger compartment of the vehicle. Refer to Group 23 - Body for the procedures.
- (9) Connect the battery negative cable.

COMPRESSOR

The compressor may be removed and repositioned without disconnecting the refrigerant lines or discharging the refrigerant system. Discharging is not necessary if servicing the compressor clutch or clutch coil, the engine, the cylinder head, or the generator.

WARNING: REVIEW THE WARNINGS AND CAUTIONS IN THE GENERAL INFORMATION SECTION NEAR THE FRONT OF THIS GROUP BEFORE PERFORMING THE FOLLOWING OPERATION.

REMOVAL

- (1) Recover the refrigerant from the refrigerant system. See Refrigerant Recovery in the Service Procedures section of this group.
- (2) Disconnect and isolate the battery negative cable.
- (3) Remove the serpentine drive belt. Refer to Group 7 - Cooling System for the procedures.
- (4) Unplug the compressor clutch coil wire harness connector.
- (5) Remove the suction and discharge refrigerant line manifold from the compressor. See Suction and Discharge Line in the Removal and Installation section of this group for the procedures. Install plugs in, or tape over all of the opened refrigerant fittings.
- (6) Remove the four screws that secure the compressor to the mounting bracket (Fig. 25).
- (7) Remove the compressor from the mounting bracket.

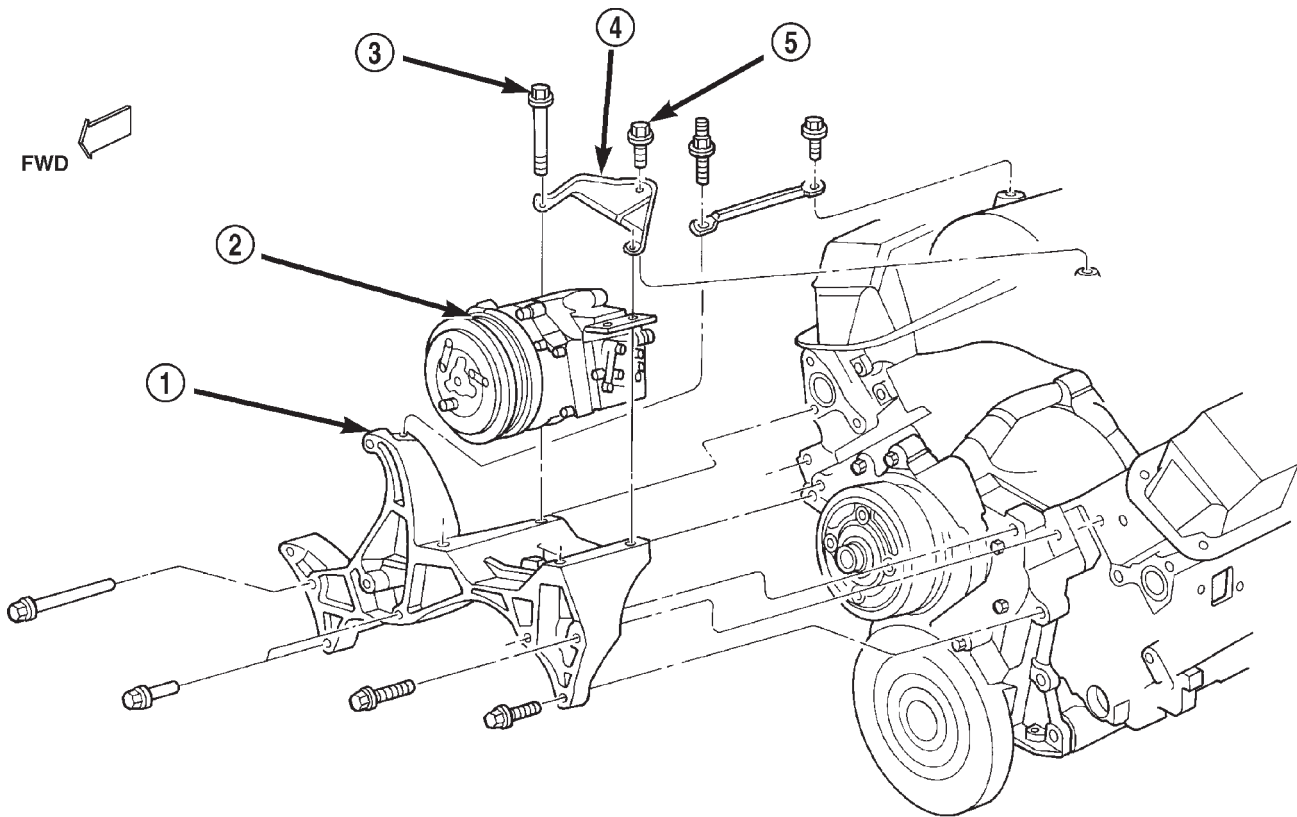

Fig. 25 Compressor Remove/Install - Typical

80a89405

- 1 - BRACKET
- 2 - COMPRESSOR
- 3 - SCREW & WASHER

- 4 - BRACE
- 5 - BOLT

REMOVAL AND INSTALLATION (Continued)

INSTALLATION

NOTE: If a replacement compressor is being installed, be certain to check the refrigerant oil level. See Refrigerant Oil Level in the Service Procedures section of this group. Use only refrigerant oil of the type recommended for the compressor in the vehicle.

(1) Install the compressor to the mounting bracket. Tighten the four mounting screws to 27 N·m (20 ft. lbs.).

(2) Remove the tape or plugs from all of the opened refrigerant line fittings. Install the suction and discharge line manifold to the compressor. See Suction and Discharge Line in the Removal and Installation section of this group for the procedures.

(3) Install the serpentine drive belt. Refer to Group 7 - Cooling System for the procedures.

(4) Plug in the compressor clutch coil wire harness connector.

(5) Connect the battery negative cable.

(6) Evacuate the refrigerant system. See Refrigerant System Evacuate in the Service Procedures section of this group.

(7) Charge the refrigerant system. See Refrigerant System Charge in the Service Procedures section of this group.

COMPRESSOR CLUTCH

The refrigerant system can remain fully-charged during compressor clutch, pulley, or coil replacement. The compressor clutch can be serviced in the vehicle.

REMOVAL

(1) Disconnect and isolate the battery negative cable.

(2) Remove the serpentine drive belt. Refer to Group 7 - Cooling System for the procedures.

(3) Unplug the compressor clutch coil wire harness connector.

(4) Insert the two pins of the spanner wrench (Special Tool 6462 in Kit 6460) into the holes of the clutch plate. Hold the clutch plate stationary and remove the hex nut (Fig. 26).

(5) Remove the clutch plate and the clutch shims.

(6) Remove the external front housing snap ring with snap ring pliers (Fig. 27).

(7) Install the lip of the rotor puller (Special Tool C-6141-1 in Kit 6460) into the snap ring groove exposed in Step 6, and install the shaft protector (Special Tool C-6141-2 in Kit 6460) (Fig. 28).

(8) Install the puller through-bolts (Special Tool C-6461) through the puller flange and into the jaws of the rotor puller and tighten (Fig. 29). Turn the

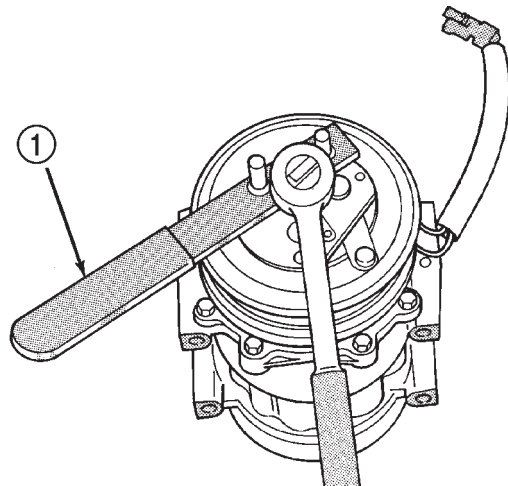

J9124-27

Fig. 26 Clutch Nut Remove

1 - FRONT PLATE SPANNER

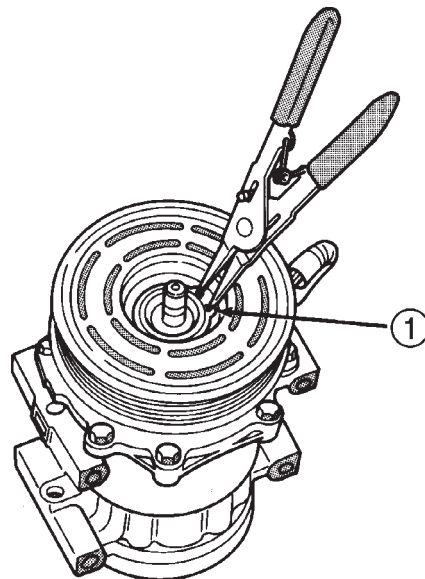

J8924-20

Fig. 27 External Snap Ring Remove

1 - EXTERNAL SNAP RING

puller center bolt clockwise until the rotor pulley is free.

(9) Remove the screw and retainer from the clutch coil lead wire harness on the compressor front housing (Fig. 30).

(10) Remove the snap ring from the compressor hub and remove the clutch field coil (Fig. 31). Slide the clutch field coil off of the compressor hub.

REMOVAL AND INSTALLATION (Continued)

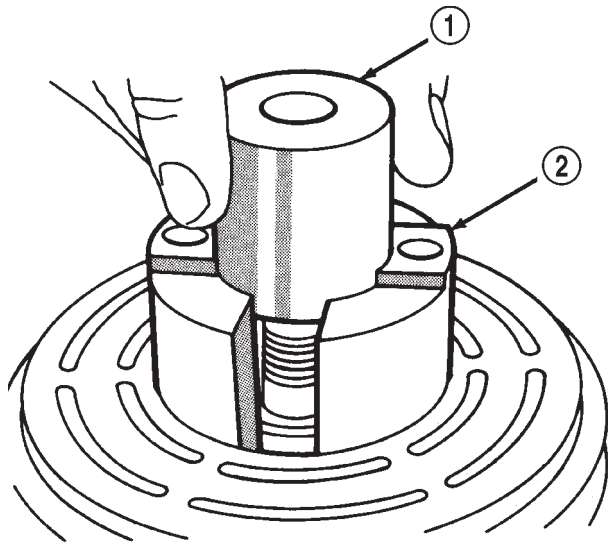

J8924-21

Fig. 28 Shaft Protector and Puller

- 1 - PULLER SHAFT PROTECTOR
- 2 - JAWS

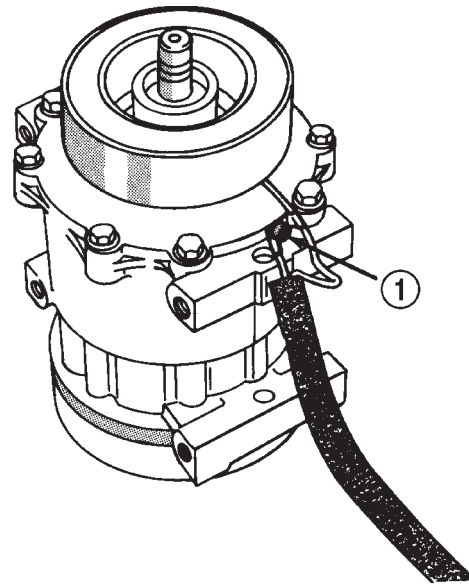

J8924-23

Fig. 30 Clutch Coil Lead Wire Harness

- 1 - CLIP

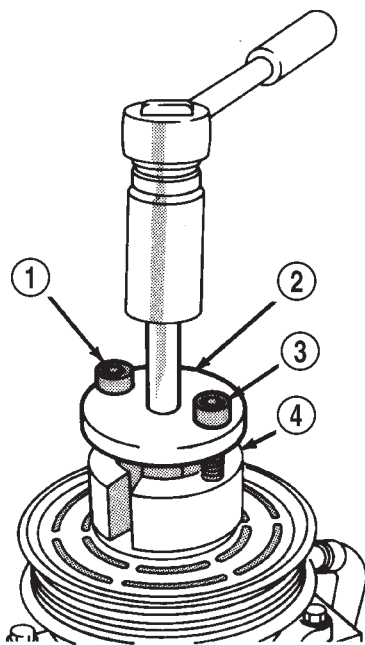

J8924-22

Fig. 29 Install Puller Plate

- 1 - BOLT
- 2 - PULLER PLATE AND BOLT
- 3 - BOLT
- 4 - JAWS

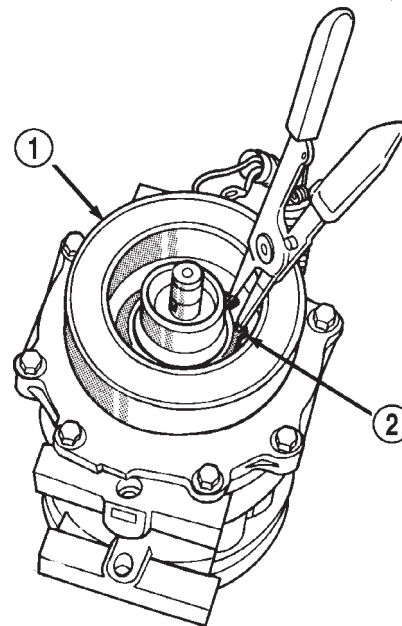

J8924-24

Fig. 31 Clutch Field Coil Snap Ring Remove

- 1 - FIELD COIL
- 2 - SNAP RING

INSPECTION

Examine the friction surfaces of the clutch pulley and the front plate for wear. The pulley and front

plate should be replaced if there is excessive wear or scoring.

If the friction surfaces are oily, inspect the shaft and nose area of the compressor for oil. Remove the felt from the front cover. If the felt is saturated with oil, the shaft seal is leaking and the compressor must be replaced.

REMOVAL AND INSTALLATION (Continued)

Check the clutch pulley bearing for roughness or excessive leakage of grease. Replace the bearing, if required.

INSTALLATION

- (1) Install the clutch field coil and snap ring.
- (2) Install the clutch coil lead wire harness retaining clip on the compressor front housing and tighten the retaining screw.
- (3) Align the rotor assembly squarely on the front compressor housing hub.
- (4) Thread the handle (Special Tool 6464 in Kit 6460) into the driver (Special Tool 6143 in Kit 6460) (Fig. 32).



J8924-25

Fig. 32 Rotor Installer Set

(5) Place the driver tool assembly into the bearing cavity on the rotor. Make certain the outer edge of the tool rests firmly on the rotor bearing inner race (Fig. 33).

(6) Tap the end of the driver while guiding the rotor to prevent binding. Tap until the rotor bottoms against the compressor front housing hub. Listen for a distinct change of sound during the tapping process, to indicate the bottoming of the rotor.

(7) Install the external front rotor snap ring with snap ring pliers. The bevel side of the snap ring must be facing outward. Press the snap ring to make sure it is properly seated in the groove.

CAUTION: If the snap ring is not fully seated in the groove it will vibrate out, resulting in a clutch failure and severe damage to the front housing of the compressor.

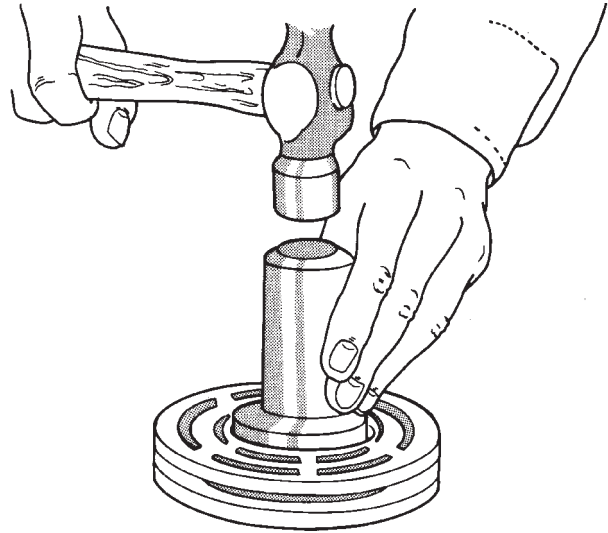

J8924-26

Fig. 33 Rotor Install

(8) Install the original clutch shims on the compressor shaft.

(9) Install the clutch plate. Use the shaft protector (Special Tool 6141-2 in Kit 6460) to install the clutch plate on the compressor shaft (Fig. 34). Tap the clutch plate over the compressor shaft until it has bottomed against the clutch shims. Listen for a distinct change of sound during the tapping process, to indicate the bottoming of the clutch plate.

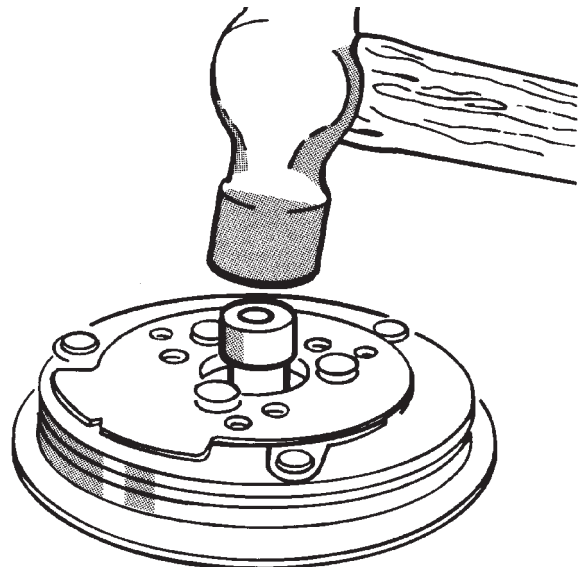

J8924-27

Fig. 34 Clutch Plate Install

(10) Replace the compressor shaft hex nut. Tighten the nut to 14.4 N·m (10.5 ft. lbs.).

(11) Check the clutch air gap with a feeler gauge (Fig. 35). If the air gap does not meet the specifica-

REMOVAL AND INSTALLATION (Continued)

tion, add or subtract shims as required. The air gap specification is 0.41 to 0.79 millimeter (0.016 to 0.031 inch). If the air gap is not consistent around the circumference of the clutch, lightly pry up at the minimum variations. Lightly tap down at the points of maximum variation.

NOTE: The air gap is determined by the spacer shims. When installing an original, or a new clutch assembly, try the original shims first. When installing a new clutch onto a compressor that previously did not have a clutch, use 1.0, 0.50, and 0.13 millimeter (0.040, 0.020, and 0.005 inch) shims from the clutch hardware package that is provided with the new clutch.

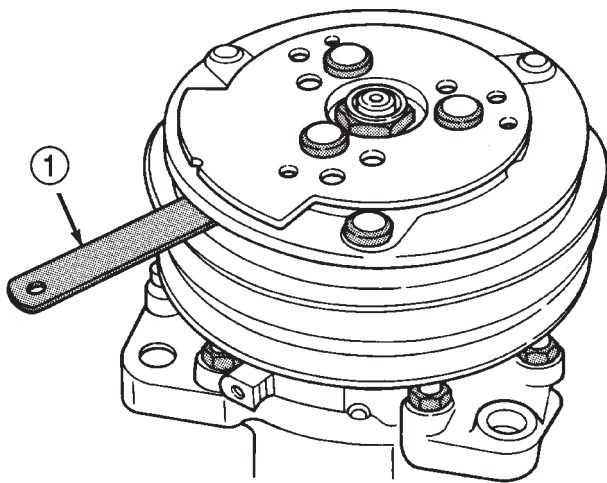

J8924-28

Fig. 35 Check Clutch Air Gap

1 - FEELER GAUGE

(12) Reverse the remaining removal procedures to complete the installation.

CLUTCH BREAK-IN

After a new compressor clutch has been installed, cycle the compressor clutch approximately twenty times (five seconds on, then five seconds off). During this procedure, set the heater-A/C control to the recirculation mode (Max-A/C), the blower motor switch to the highest speed position, and the engine speed at 1500 to 2000 rpm. This procedure (burnishing) will seat the opposing friction surfaces and provide a higher compressor clutch torque capability.

COMPRESSOR CLUTCH RELAY

- (1) Disconnect and isolate the battery negative cable.
- (2) Remove the cover from the Power Distribution Center (PDC) (Fig. 36).

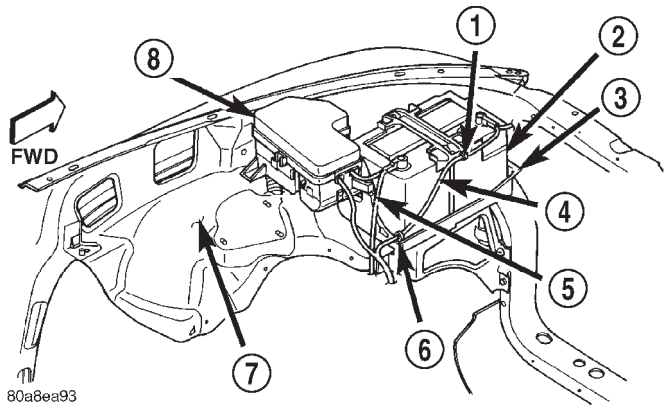

80a8ea93

Fig. 36 Power Distribution Center

- 1 - CLIP
- 2 - BATTERY
- 3 - TRAY
- 4 - NEGATIVE CABLE
- 5 - POSITIVE CABLE
- 6 - CLIP
- 7 - FENDER INNER SHIELD
- 8 - POWER DISTRIBUTION CENTER

- (3) Refer to the label on the PDC for compressor clutch relay identification and location.
- (4) Unplug the compressor clutch relay from the PDC.
- (5) Install the compressor clutch relay by aligning the relay terminals with the cavities in the PDC and pushing the relay firmly into place.
- (6) Install the PDC cover.
- (7) Connect the battery negative cable.
- (8) Test the relay operation.

CONDENSER

WARNING: REVIEW THE WARNINGS AND CAUTIONS IN THE GENERAL INFORMATION SECTION NEAR THE FRONT OF THIS GROUP BEFORE PERFORMING THE FOLLOWING OPERATION.

CAUTION: Before removing the condenser, note the location of each of the radiator and condenser air seals. These seals are used to direct air through the condenser and radiator. The air seals must be reinstalled in their proper locations in order for the air conditioning and engine cooling systems to perform as designed.

REMOVAL

- (1) Disconnect and isolate the battery negative cable.
- (2) Recover the refrigerant from the refrigerant system. See Refrigerant Recovery in the Service Procedures section of this group.

REMOVAL AND INSTALLATION (Continued)

(3) Disconnect the refrigerant line fitting that secures the discharge line to the condenser inlet (Fig. 37). Install plugs in, or tape over all of the opened refrigerant line fittings.

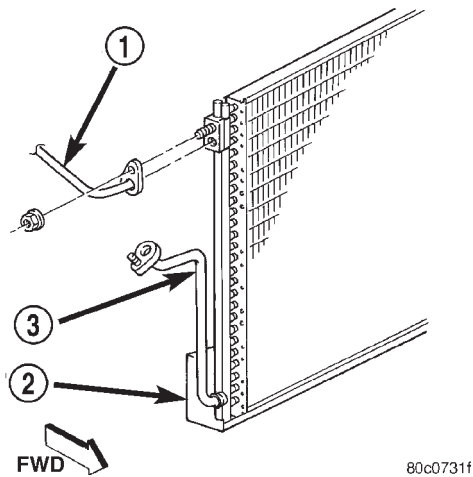

Fig. 37 Condenser Line Fittings

- 1 - DISCHARGE LINE
- 2 - CONDENSOR
- 3 - TO LIQUID LINE

(4) Disconnect the refrigerant line fitting that secures the liquid line to the condenser outlet. Install plugs in, or tape over all of the opened refrigerant line fittings.

(5) Remove the two screws that secure the radiator and fan shroud module to the inside of the upper radiator crossmember.

(6) On models equipped with a V-8 engine, remove the radiator from the engine compartment. Refer to Cooling Systems for the procedures.

(7) Remove the two screws that secure the condenser to the outside of the upper radiator crossmember (Fig. 38).

(8) Tilt the top of the radiator and fan shroud module towards the engine, using care not to damage the radiator fins on the engine cooling fan.

(9) With the radiator and fan shroud module tilted, carefully lift the condenser upwards until the lower condenser mounts are clear of the isolators in the lower crossmember.

(10) Remove the condenser from the vehicle.

INSTALLATION

(1) With the radiator and fan shroud module tilted towards the engine, carefully position the lower condenser mounts in the lower crossmember isolators.

(2) Reinstall the two screws that secure the condenser to the outside of the upper radiator crossmember and tighten to 10.7 N·m (95 in. lbs.).

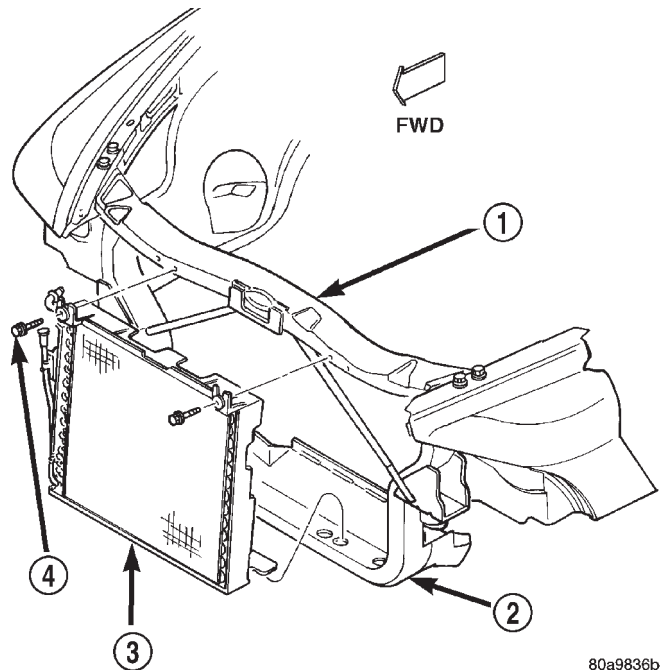

Fig. 38 Condenser Remove/Install - Typical

- 1 - UPPER CROSSMEMBER
- 2 - LOWER CROSSMEMBER
- 3 - CONDENSER
- 4 - SCREW

(3) On models equipped with a V-8 engine, reinstall the radiator to the engine compartment. Refer to Cooling Systems for the procedures.

(4) Reinstall the two screws that secure the radiator and fan shroud module to the inside of the upper radiator crossmember.

(5) Remove the plugs or tape from the refrigerant line fittings on the liquid line and the condenser outlet. Connect the liquid line to the condenser outlet. Tighten the fitting to 25.99 ± 3.39 N·m (230 ± 30 in. lbs.).

(6) Remove the plugs or tape from the refrigerant line fittings on the discharge line and the condenser inlet. Connect the discharge line to the condenser inlet. Tighten the fitting to 25.99 ± 3.39 N·m (230 ± 30 in. lbs.).

(7) Check that all of the condenser and radiator air seals are in their proper locations.

(8) Connect the battery negative cable.

(9) Evacuate the refrigerant system. See Refrigerant System Evacuate in the Service Procedures section of this group.

(10) Charge the refrigerant system. See Refrigerant System Charge in the Service Procedures section of this group.

REMOVAL AND INSTALLATION (Continued)

NOTE: If the condenser is replaced, add 30 milliliters (1 fluid ounce) of refrigerant oil to the refrigerant system. Use only refrigerant oil of the type recommended for the compressor in the vehicle.

DUCTS AND OUTLETS

WARNING: ON VEHICLES EQUIPPED WITH AIR-BAGS, REFER TO GROUP 8M - PASSIVE RESTRAINT SYSTEMS BEFORE ATTEMPTING ANY STEERING WHEEL, STEERING COLUMN, OR INSTRUMENT PANEL COMPONENT DIAGNOSIS OR SERVICE. FAILURE TO TAKE THE PROPER PRECAUTIONS COULD RESULT IN ACCIDENTAL AIR-BAG DEPLOYMENT AND POSSIBLE PERSONAL INJURY.

PANEL AND DEFROSTER DUCTS

The panel and defroster ducts are integral to the instrument panel assembly. The defroster outlets are integral to the instrument panel top cover. Refer to Instrument Panel Assembly in the Removal and Installation section of Group 8E - Instrument Panel Systems for the service procedures.

OUTLET BARRELS

In addition to the panel outlet barrels in the instrument panel, models equipped with the bucket seat option have two outlet barrels for the rear seat passengers located near the top of upper rear panel of the center floor console. The service procedures for all of these outlet barrels is the same. Models with the optional rear overhead A/C unit also have four outlet barrels located in the outlet bezel on the headliner, but these outlet barrels are only serviced as a unit with the rear overhead A/C outlet bezel.

(1) Using a trim stick or another suitable wide-bladed flat tool, gently pry at the sides of the outlet barrels to release the snap-fit pivots on the barrel from the pivot pins in the outlet housing of the instrument panel top cover, the instrument cluster bezel or the center floor console (Fig. 39).

(2) To install the outlet barrel, position the barrel in the outlet housing and press inwards firmly and evenly until the barrel snaps into place.

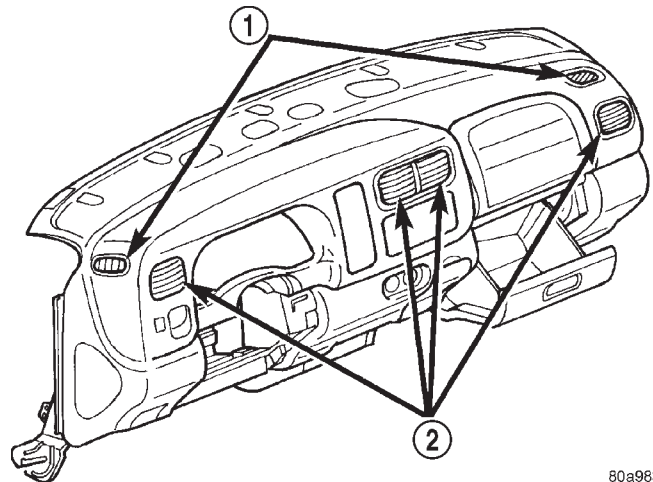

80a98381

Fig. 39 Outlet Barrels

- 1 - DEMISTER OUTLETS
- 2 - PANEL OUTLETS

FRONT SEAT FLOOR DUCT

(1) Remove the three screws that secure the floor duct to the bottom of the heater-A/C housing (Fig. 40).

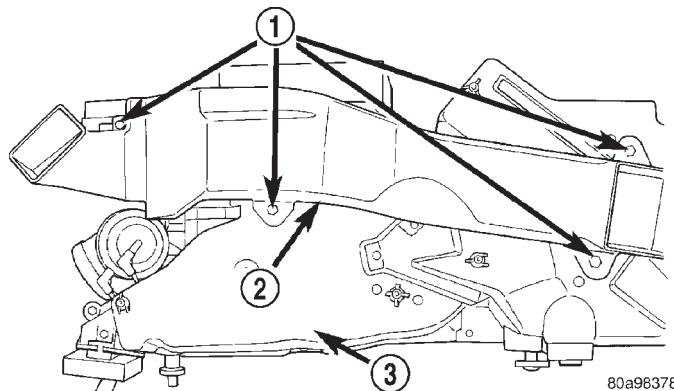

80a98378

Fig. 40 Front Seat Floor Duct Remove/Install (Typical)

- 1 - SCREWS
- 2 - FLOOR DUCT
- 3 - HEATER-A/C HOUSING

(2) Remove the floor duct from the heater-A/C housing.

(3) Reverse the removal procedures to install. Tighten the mounting screws to 2.2 N·m (20 in. lbs.).

REMOVAL AND INSTALLATION (Continued)

REAR SEAT FLOOR DUCT CONTROL

SPLIT BENCH SEAT

(1) Remove the three retainers that secure the HVAC rear bezel to the brackets near the back of the front seat center section (Fig. 41).

(2) Pull the bezel away from the back of the front seat far enough to access and disengage the control cable retainer and cable end from the control.

(3) Reverse the removal procedures to install.

BUCKET SEAT

The rear floor duct control and linkage are only serviced as a unit with the console duct assembly.

(1) Remove the four screws that secure the console bin and remove the bin from the floor console (Fig. 42).

(2) Reach through the top of the console to disengage the control rod end from the floor duct damper door pivot.

(3) Remove the floor console from the vehicle and disassemble as required to remove the console duct and control assembly from the console as a unit. Refer to Group 23 - Body for the procedures.

(4) Reverse the removal procedures to install.

REAR SEAT FLOOR DUCT

The rear seat floor duct damper door is only serviced as part of the rear seat floor duct on bench seat models, or the center seat floor duct on bucket seat models.

(1) Remove the carpeting from the floor panel transmission tunnel. Refer to Group 23 - Body for the procedures.

(2) Remove the retainers that secure the ducts to the floor panel transmission tunnel (Fig. 43) or (Fig. 44).

(3) Remove the duct(s) from the floor panel as required.

(4) Reverse the removal procedures to install.

DEMISTER DUCT ADAPTER

(1) Roll the instrument panel assembly down, but do not remove it from the vehicle. Refer to Instrument Panel Assembly in the Removal and Installation section of Group 8E - Instrument Panel Systems for the procedures.

(2) Disconnect the flexible demister duct hose from the demister duct adapter on the top of the heater-A/C housing.

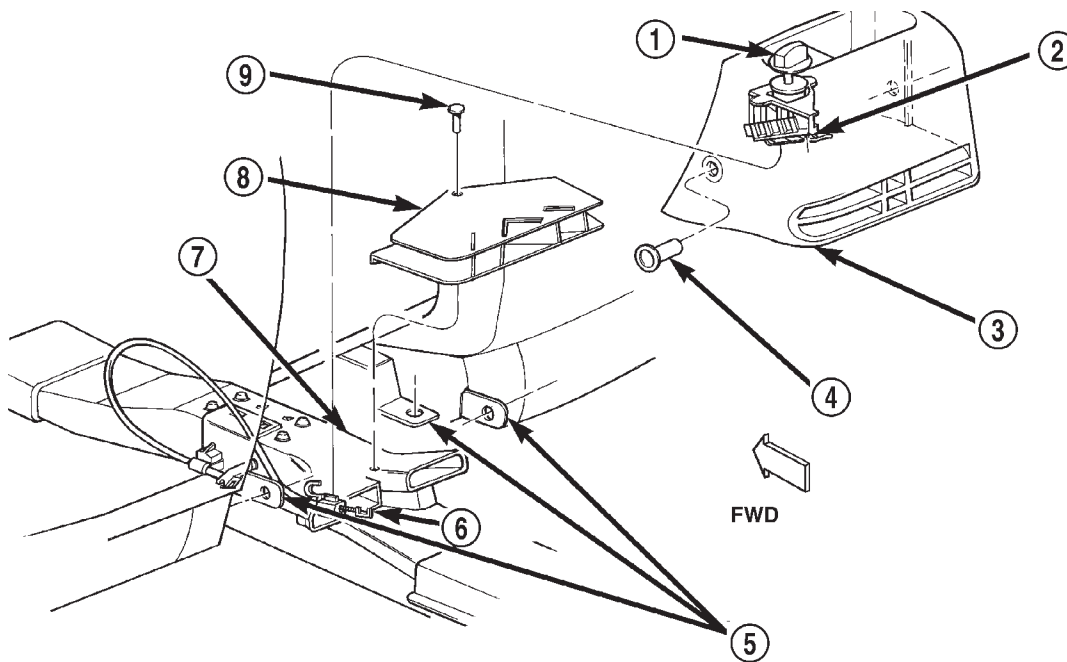

Fig. 41 Rear Seat Floor Duct Control - Split Bench Seat

- 1 - KNOB
- 2 - CONTROL
- 3 - BEZEL
- 4 - RETAINER
- 5 - FRONT SEAT BRACKETS

- 6 - CABLE
- 7 - DUCT
- 8 - DIFFUSER
- 9 - RETAINER

REMOVAL AND INSTALLATION (Continued)

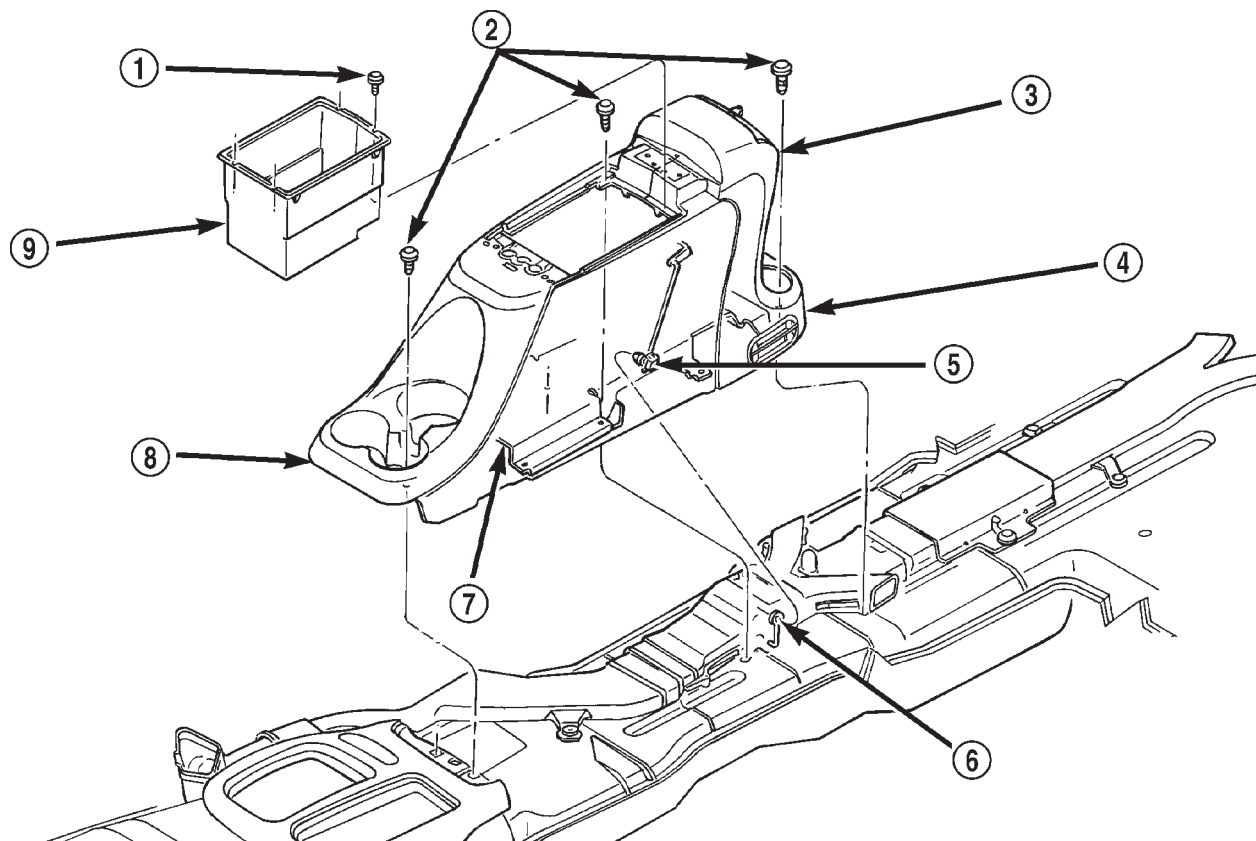

Fig. 42 Rear Seat Floor Duct Control - Bucket Seat

80b11cfe

- | | |
|----------------------|-----------------------|
| 1 - SCREW | 6 - DAMPER DOOR PIVOT |
| 2 - SCREW | 7 - BASE PLATE |
| 3 - UPPER REAR PANEL | 8 - FLOOR CONSOLE |
| 4 - LOWER REAR PANEL | 9 - BIN |
| 5 - CONTROL ROD END | |

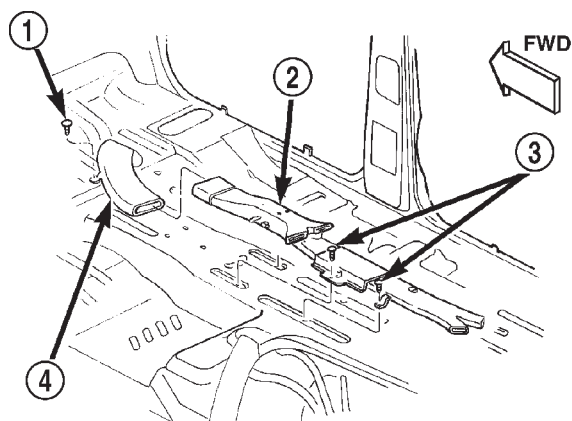

Fig. 43 Rear Seat Floor Ducts Remove/Install - Split Bench Seat

80b2b5fe

- | |
|--------------------------|
| 1 - RETAINER |
| 2 - REAR SEAT FLOOR DUCT |
| 3 - RETAINER |
| 4 - FRONT TUNNEL DUCT |

(3) Remove the two screws that secure the demister duct adapter to the top of the heater-A/C housing (Fig. 45).

(4) Remove the demister duct adapter from the heater-A/C housing.

(5) Reverse the removal procedures to install. Tighten the mounting screws to 2.2 N·m (20 in. lbs.).

DEMISTER HOSE

(1) Remove the heater-A/C control from the instrument panel. See Heater-A/C Control in the Removal and Installation section of this group for the procedures.

(2) Reach through the heater-A/C control opening in the instrument panel to access and remove the screw that secures the flexible demister duct hose to the demister duct tee.

(3) Roll the instrument panel assembly down, but do not remove it from the vehicle. Refer to Instrument Panel Assembly in the Removal and Installation section of Group 8E - Instrument Panel Systems for the procedures.

REMOVAL AND INSTALLATION (Continued)

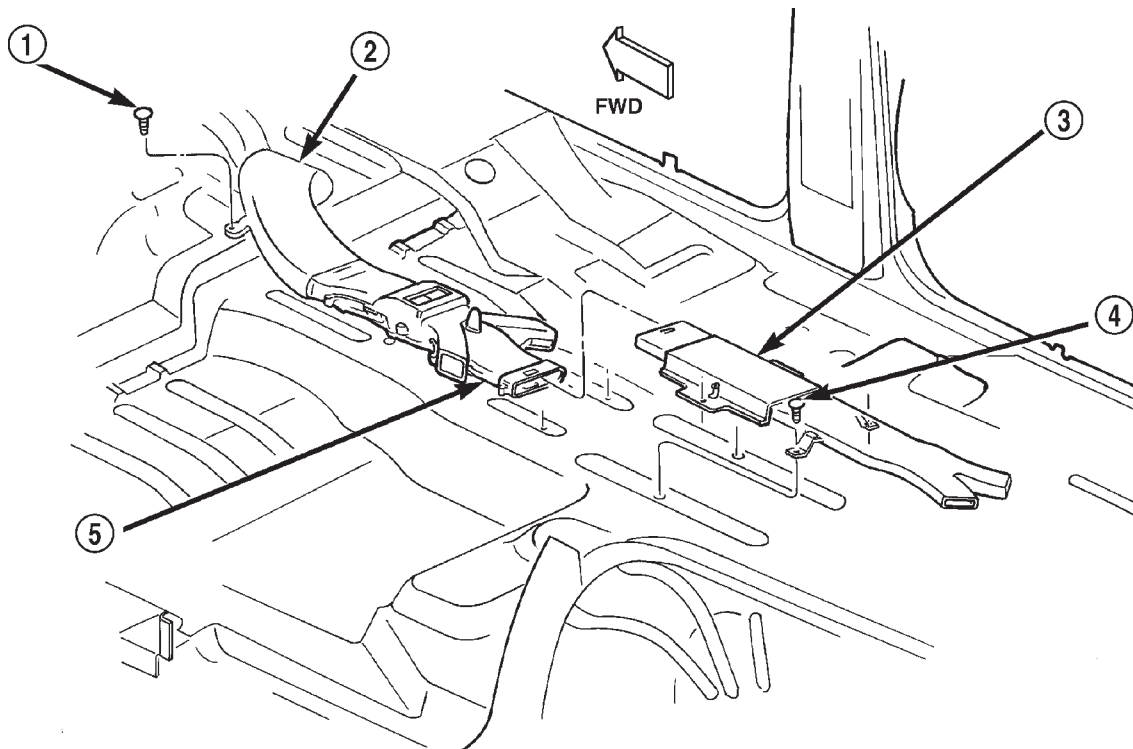

80b2b5ff

Fig. 44 Rear Seat Floor Ducts Remove/Install - Bucket Seat

1 - RETAINER

2 - FRONT TUNNEL DUCT

3 - REAR SEAT FLOOR DUCT

4 - RETAINER

5 - CENTER SEAT FLOOR DUCT

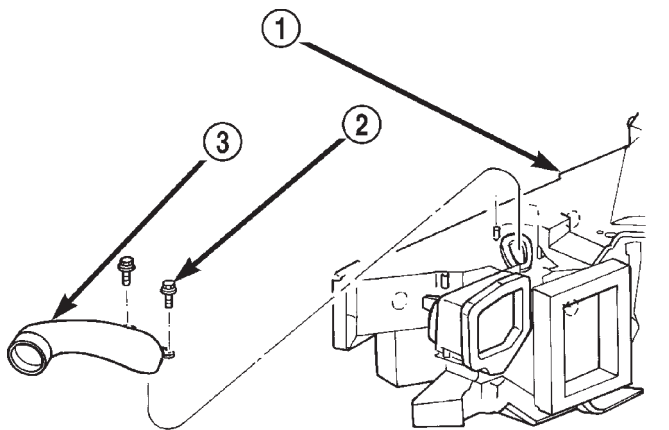

80a98370

Fig. 45 Demister Duct Adapter Remove/Install

1 - HEATER-A/C HOUSING

2 - SCREW

3 - ADAPTER

(4) Disconnect the flexible demister duct hose from the demister duct adapter on the top of the heater-A/C housing.

(5) Remove the demister duct hose from the demister duct tee near the underside of the instrument panel top cover.

(6) Reverse the removal procedures to install. Tighten the hose mounting screw to 2.2 N·m (20 in. lbs.).

DEMISTER DUCTS AND OUTLETS

(1) Remove the instrument panel top cover from the instrument panel. Refer to Instrument Panel Top Cover in the Removal and Installation section of Group 8E - Instrument Panel Systems for the procedures.

(2) Remove the screws (two - left side, three - right side) that secure the demister ducts to the instrument panel top cover (Fig. 46).

(3) Using a trim stick or another suitable wide flat-bladed tool, gently pry between the end of the demister duct and the demister outlet flange to release the duct from the outlet.

(4) Remove the demister ducts and the tee from the instrument panel top cover.

(5) Squeeze the demister outlet flange from the underside of the instrument panel top cover and push it out through the top.

REMOVAL AND INSTALLATION (Continued)

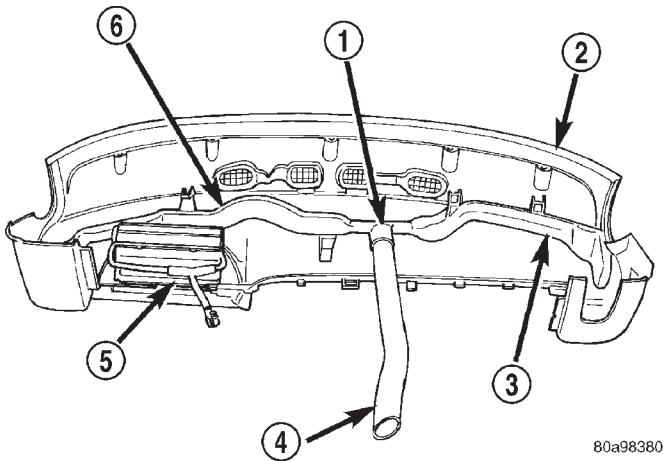

Fig. 46 Demister Ducts Remove/Install

- 1 - DEMISTER DUCT TEE
- 2 - INSTRUMENT PANEL TOP COVER
- 3 - LEFT DEMISTER DUCT
- 4 - DEMISTER HOSE
- 5 - PASSENGER SIDE AIRBAG MODULE
- 6 - RIGHT DEMISTER DUCT

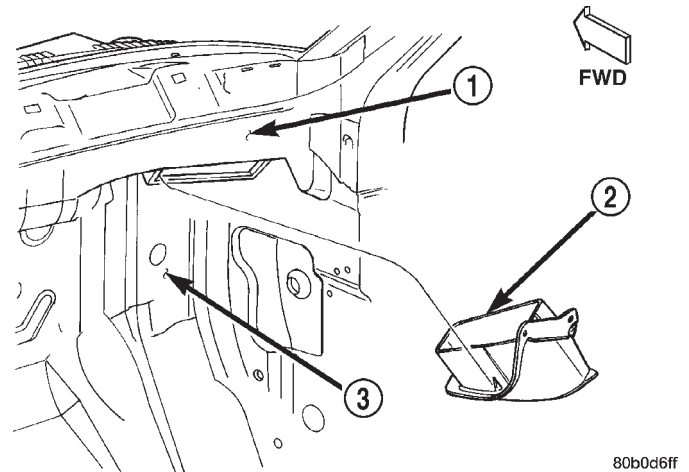

Fig. 47 Heater-A/C Housing Plenum Adapter Remove/Install

- 1 - PLENUM PANEL
- 2 - PLENUM ADAPTER
- 3 - DASH PANEL

REAR OVERHEAD A/C OUTLET BEZEL

The rear overhead A/C outlet bezel is used only on models with the optional rear overhead A/C unit. The outlet barrels located in the bezel are only serviced as a unit with the rear overhead A/C outlet bezel.

(1) Using a trim stick or another suitable wide flat-bladed tool, gently pry between both ends of the rear overhead A/C outlet bezel and the headliner to release the two snap clip retainers that secure the bezel to the rear overhead A/C unit housing (Fig. 48).

(6) Using a trim stick or another suitable wide flat-bladed tool, gently pry between the end of the demister duct and the demister outlet flange to release the duct from the outlet.

(7) Remove the demister ducts and the tee from the instrument panel top cover.

(8) Squeeze the demister outlet flange from the underside of the instrument panel top cover and push it out through the top.

(9) Reverse the removal procedures to install. Tighten the mounting screws to 2.2 N·m (20 in. lbs.).

HEATER-A/C HOUSING PLENUM ADAPTER

(1) Remove the heater-A/C housing from the vehicle. See Heater-A/C Housing in the Removal and Installation section of this group for the procedures.

(2) Slide the heater-A/C housing plenum adapter (Fig. 47) all the way to one side of the plenum opening.

(3) Pull downwards sharply and firmly on the opposite side of the plenum adapter to disengage the snap feature from the plenum opening.

(4) Remove the plenum adapter from the plenum panel.

(5) When reinstalling the heater-A/C housing plenum adapter to the plenum panel opening, be certain that the snap features on each side of the adapter are fully engaged with the sides of the plenum panel opening. This must be a water tight connection to prevent leaks.

(6) Reverse the remaining removal procedures to complete the installation.

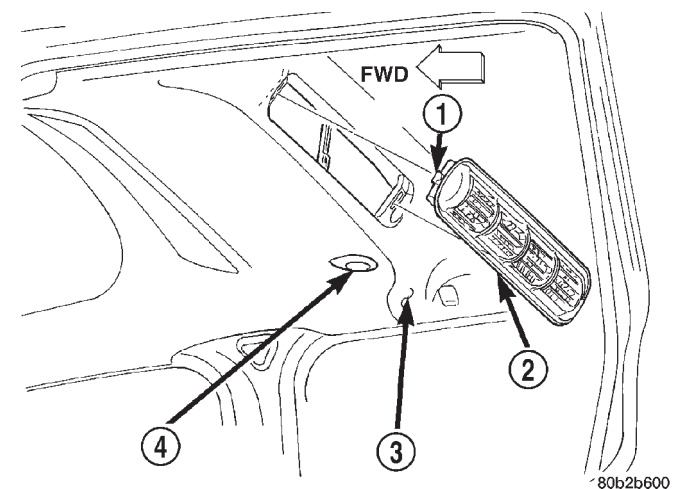

Fig. 48 Rear Overhead A/C Outlet Bezel Remove/Install

- 1 - RETAINER
- 2 - OUTLET BEZEL
- 3 - HEADLINER
- 4 - REAR BLOWER MOTOR SWITCH

REMOVAL AND INSTALLATION (Continued)

- (2) Remove the rear overhead A/C outlet bezel from the headliner mounting hole.
- (3) Reverse the removal procedures to install.

ELECTRONIC CYCLING CLUTCH SWITCH

REMOVAL

- (1) Disconnect and isolate the battery negative cable.
- (2) Unplug the wire harness connector from the electronic cycling clutch switch near the expansion valve (Fig. 49).

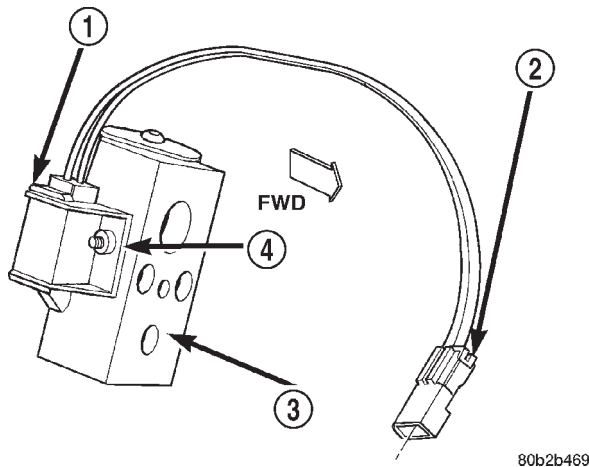

Fig. 49 Electronic Cycling Clutch Switch Remove/Install

- 1 - ELECTRONIC CYCLING CLUTCH SWITCH
- 2 - WIRE HARNESS CONNECTOR
- 3 - EXPANSION VALVE
- 4 - FASTENER

(3) Remove and discard the fastener that secures the electronic cycling clutch switch to the outboard side of the expansion valve.

(4) Pull the electronic cycling clutch switch away from the side of the expansion valve far enough for the thermistor probe capillary tube to clear the well in the expansion valve. The washer bottle may have to be removed.

NOTE: The capillary tube well in the expansion valve is filled with a special thermally-conductive grease. This grease should be removed from the old parts and reused on the new parts whenever the electronic cycling clutch switch or the expansion valve are replaced.

INSTALLATION

(1) Insert the thermistor probe capillary tube of the electronic cycling clutch switch into the well on the outboard side of the expansion valve.

(2) Install the electronic cycling clutch switch to the expansion valve and secure it with a new fastener.

(3) Plug the wire harness connector into the electronic cycling clutch switch.

(4) Connect the battery negative cable.

EVAPORATOR COIL

WARNING: REVIEW THE WARNINGS AND CAUTIONS IN THE GENERAL INFORMATION SECTION NEAR THE FRONT OF THIS GROUP BEFORE PERFORMING THE FOLLOWING OPERATION.

WARNING: ON VEHICLES EQUIPPED WITH AIR-BAGS, REFER TO GROUP 8M - PASSIVE RESTRAINT SYSTEMS BEFORE ATTEMPTING ANY STEERING WHEEL, STEERING COLUMN, OR INSTRUMENT PANEL COMPONENT DIAGNOSIS OR SERVICE. FAILURE TO TAKE THE PROPER PRECAUTIONS COULD RESULT IN ACCIDENTAL AIR-BAG DEPLOYMENT AND POSSIBLE PERSONAL INJURY.

FRONT

REMOVAL

(1) Remove the heater-A/C housing from the vehicle, and remove the housing cover. See Heater-A/C Housing in the Removal and Installation section of this group for the procedures.

(2) Lift the front evaporator coil out of the heater-A/C housing (Fig. 50).

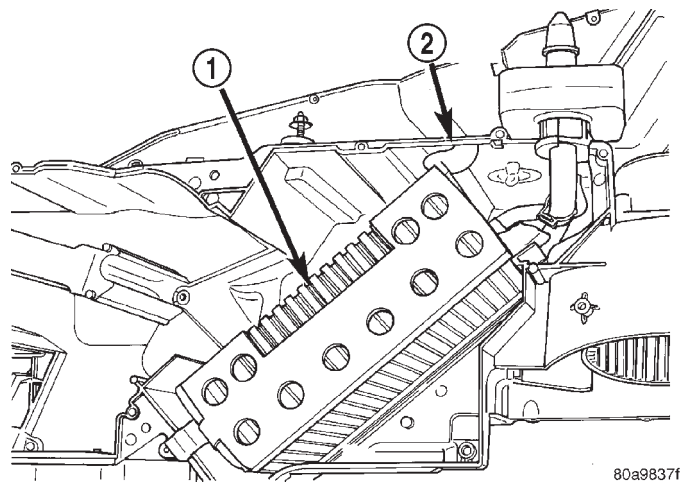

Fig. 50 Evaporator Coil Remove/Install

- 1 - EVAPORATOR COIL
- 2 - HEATER-A/C HOUSING

REMOVAL AND INSTALLATION (Continued)

INSTALLATION

(1) Insert the front evaporator coil into the bottom of the heater-A/C housing.

(2) Reassemble and reinstall the heater-A/C housing in the vehicle. See Heater-A/C Housing in the Removal and Installation section of this group for the procedures.

NOTE: If the front evaporator coil is replaced, add 60 milliliters (2 fluid ounces) of refrigerant oil to the refrigerant system. Use only refrigerant oil of the type recommended for the compressor in the vehicle.

REAR

The rear evaporator coil is used only on models with the optional rear overhead A/C unit.

REMOVAL

(1) Disconnect and isolate the battery negative cable.

(2) Recover the refrigerant from the refrigerant system. See Refrigerant Recovery in the Service Procedures section of this group.

(3) Remove the headliner from the passenger compartment of the vehicle. Refer to Group 23 - Body for the procedures.

(4) From the passenger compartment, remove the nuts that secure the block fittings at the top of the B-pillar refrigerant lines to the studs on the rear overhead A/C unit, and disengage the fittings (Fig. 51). Install plugs in, or tape over all of the opened refrigerant line fittings.

(5) Disconnect the B-pillar drain hoses from the wye fittings on each side of the rear overhead A/C unit (Fig. 52).

(6) Remove the nine screws that secure the lower housing cover to the rear overhead A/C unit.

(7) Release the lower housing cover snap retainer near the center of the outlet side (rear) of the rear overhead A/C unit (Fig. 53).

(8) Feed the rear blower motor switch wire harness and connector through the hole in the right end of the rear overhead A/C unit lower housing cover while removing the cover from the unit.

(9) Remove the screw that secures the rear overhead A/C refrigerant tube and block fitting retaining strap to the right side of the upper housing cover (Fig. 54).

(10) Remove the two screws that secure the rear evaporator coil to the rear overhead A/C unit upper housing cover (Fig. 55).

(11) Remove the rear evaporator coil from the rear overhead A/C unit.

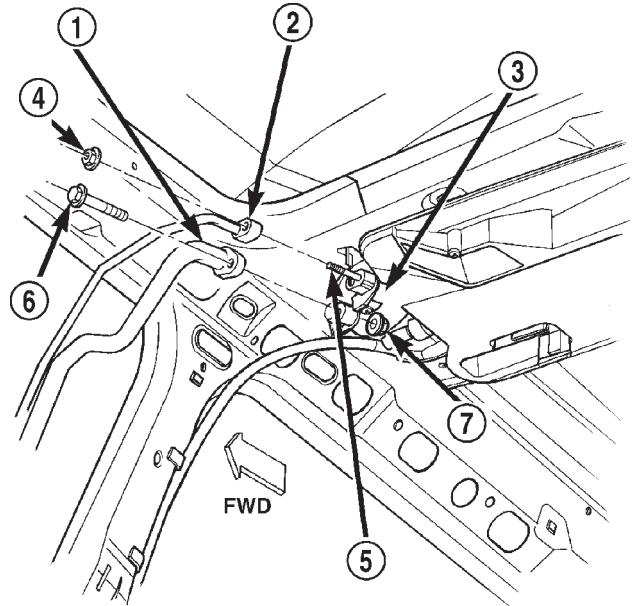

80b3c5eb

Fig. 51 Rear Overhead A/C Unit Refrigerant Line Remove/Install

- 1 - B-PILLAR SUCTION LINE
- 2 - B-PILLAR LIQUID LINE
- 3 - OVERHEAD AIR CONDITIONING UNIT
- 4 - NUT
- 5 - STUD
- 6 - BOLT
- 7 - NUT

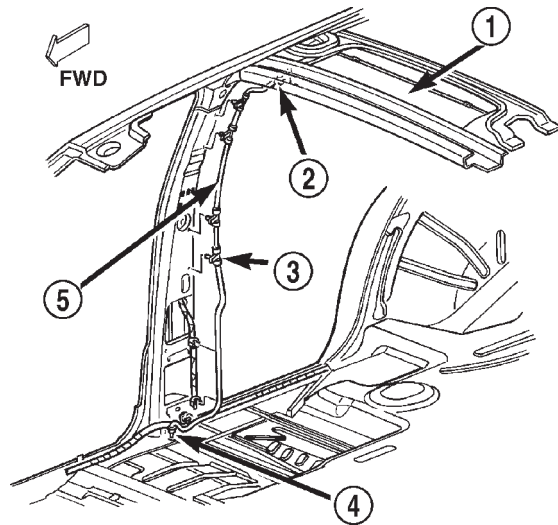

80b2b519

Fig. 52 Rear Overhead A/C Drain Hose Remove/Install

- 1 - REAR OVERHEAD A/C UNIT
- 2 - WYE FITTING
- 3 - CLIP
- 4 - GROMMET
- 5 - DRAIN HOSE

REMOVAL AND INSTALLATION (Continued)

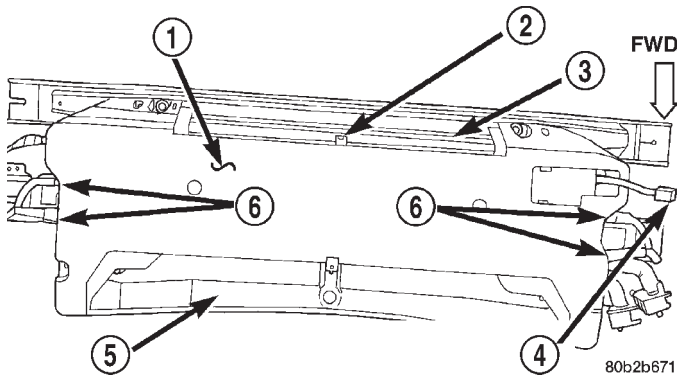

Fig. 53 Rear Overhead A/C Unit Lower Housing Cover Remove/Install

- 1 - REAR OVERHEAD A/C UNIT LOWER HOUSING COVER
- 2 - SNAP RETAINER
- 3 - OUTLET SIDE
- 4 - BLOWER MOTOR SWITCH WIRE HARNESS CONNECTOR
- 5 - INLET SIDE
- 6 - DRAIN HOSES

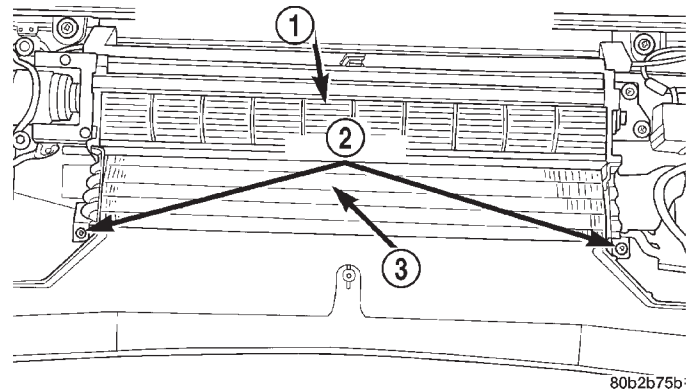

Fig. 55 Rear Evaporator Coil Remove/Install

- 1 - BLOWER WHEEL AND HOUSING
- 2 - SCREWS
- 3 - EVAPORATOR COIL

(3) Feed the rear blower motor switch wire harness and connector through the hole in the right end of the rear overhead A/C unit lower housing cover while positioning the cover to the unit.

(4) Be certain that the lower housing cover snap retainer near the center of the outlet side (rear) of the rear overhead A/C unit is engaged.

(5) Install the nine screws that secure the lower housing cover to the rear overhead A/C unit. Tighten the mounting screws to 2.2 N·m (20 in. lbs.).

(6) Connect the B-pillar drain hoses to the wye fittings on each side of the rear overhead A/C unit.

(7) Remove the tape or plugs from block fittings at the top of the B-pillar refrigerant line unit, and from the fittings on the rear overhead A/C unit. Install the B-pillar refrigerant line block fittings over the two studs on the rear overhead A/C unit and secure the connections with the mounting nuts. Tighten the mounting nuts to 11.3 N·m (100 in. lbs.).

(8) Reinstall the headliner in the passenger compartment of the vehicle. Refer to Group 23 - Body for the procedures.

(9) Connect the battery negative cable.

(10) Evacuate the refrigerant system. See Refrigerant System Evacuate in the Service Procedures section of this group.

(11) Charge the refrigerant system. See Refrigerant System Charge in the Service Procedures section of this group.

NOTE: If the rear evaporator coil and expansion valve unit is replaced, add 30 milliliters (1 fluid ounce) of refrigerant oil to the refrigerant system. Use only refrigerant oil of the type recommended for the compressor in the vehicle.

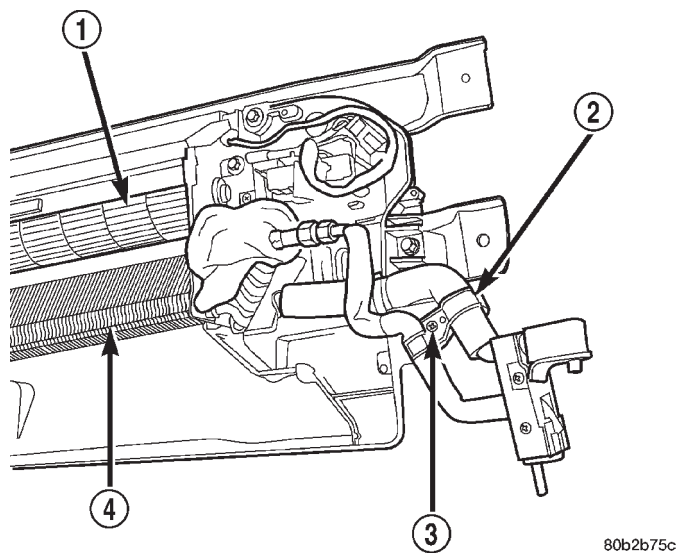

Fig. 54 Rear A/C Tube Retaining Strap Remove/Install

- 1 - BLOWER WHEEL
- 2 - RETAINING STRAP
- 3 - SCREW
- 4 - EVAPORATOR COIL

INSTALLATION

(1) Position the rear evaporator coil to the rear overhead A/C unit and secure with two mounting screws. Tighten the mounting screws to 2.2 N·m (20 in. lbs.).

(2) Install the rear overhead A/C refrigerant tube and block fitting retaining strap to the right side of the upper housing cover and secure with a screw. Tighten the mounting screws to 2.2 N·m (20 in. lbs.).

REMOVAL AND INSTALLATION (Continued)

EXPANSION VALVE

FRONT

WARNING: REVIEW THE WARNINGS AND CAUTIONS IN THE GENERAL INFORMATION SECTION NEAR THE FRONT OF THIS GROUP BEFORE PERFORMING THE FOLLOWING OPERATION.

REMOVAL

- (1) Disconnect and isolate the battery negative cable.
- (2) Recover the refrigerant from the refrigerant system. See Refrigerant Recovery in the Service Procedures section of this group.
- (3) Remove the rear liquid line from the engine compartment. See Liquid Line in the Removal and Installation section of this group for the procedures.
- (4) Remove the electronic cycling clutch switch from the outboard side of the expansion valve. See Electronic Cycling Clutch Switch in the Removal and Installation section of this group for the procedures.
- (5) Remove the two screws that secure the expansion valve to the evaporator tube mounting flange (Fig. 56).

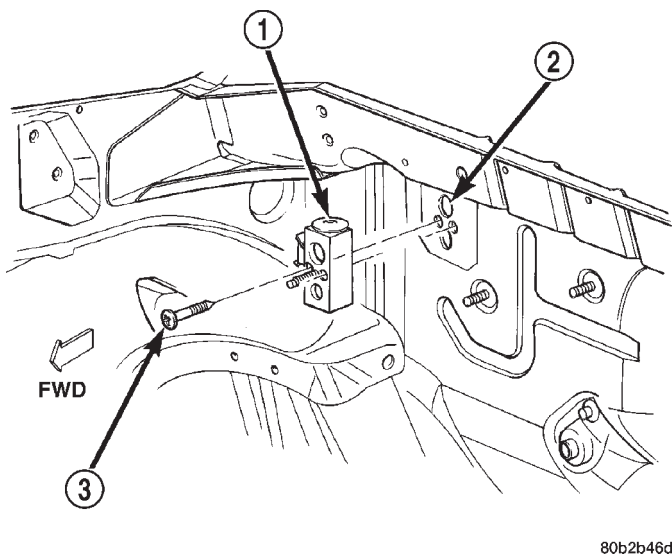

Fig. 56 Expansion Valve Remove/Install

- 1 - EXPANSION VALVE
- 2 - EVAPORATOR TUBE MOUNTING FLANGE
- 3 - SCREW

- (6) Remove the expansion valve from the evaporator tube mounting flange. Install plugs in, or tape over all of the opened refrigerant line fittings.

INSTALLATION

- (1) Remove the tape or plugs from the evaporator tubes and the evaporator tube mounting flange side

of the expansion valve. Install the expansion valve to the evaporator tube mounting flange and secure with two screws. Tighten the mounting screws to 11.4 N·m (100 in. lbs.).

- (2) Reinstall the electronic cycling clutch switch to the outboard side of the expansion valve. See Electronic Cycling Clutch Switch in the Removal and Installation section of this group for the procedures.

(3) Reinstall the rear liquid line to the engine compartment. See Liquid Line in the Removal and Installation section of this group for the procedures.

- (4) Connect the battery negative cable.

(5) Evacuate the refrigerant system. See Refrigerant System Evacuate in the Service Procedures section of this group.

(6) Charge the refrigerant system. See Refrigerant System Charge in the Service Procedures section of this group.

REAR

WARNING: REVIEW THE WARNINGS AND CAUTIONS IN THE GENERAL INFORMATION SECTION NEAR THE FRONT OF THIS GROUP BEFORE PERFORMING THE FOLLOWING OPERATION.

REMOVAL

- (1) Disconnect and isolate the battery negative cable.
- (2) Recover the refrigerant from the refrigerant system. See Refrigerant Recovery in the Service Procedures section of this group.
- (3) Remove the engine air filter housing. Refer to Group 14 - Fuel System for the procedures.
- (4) Remove the underbody line. See Underbody Refrigerant Line in the Removal and Installation section of this group for the procedures. Remove the line from the vehicle and install plugs in, or tape over, all of the open refrigerant fittings.
- (5) Disassemble the bolt (M6) from the forward (longer) section of the underbody lines to the valve. Install plugs in, or tape over the open refrigerant fittings.
- (6) Disassemble the two bolts attaching the expansion valve to the rearward (shorter) section of the underbody lines. Install plugs in, or tape over the open refrigerant fittings.

INSTALLATION

(1) Remove the tape or plugs from expansion valve and the rearward (shorter) section of the underbody lines. Align the expansion valve ports with the block fitting on the rearward lines and assemble with the two bolts.

(2) Remove the tape or plugs from the forward (longer) section of the underbody lines. Align the

REMOVAL AND INSTALLATION (Continued)

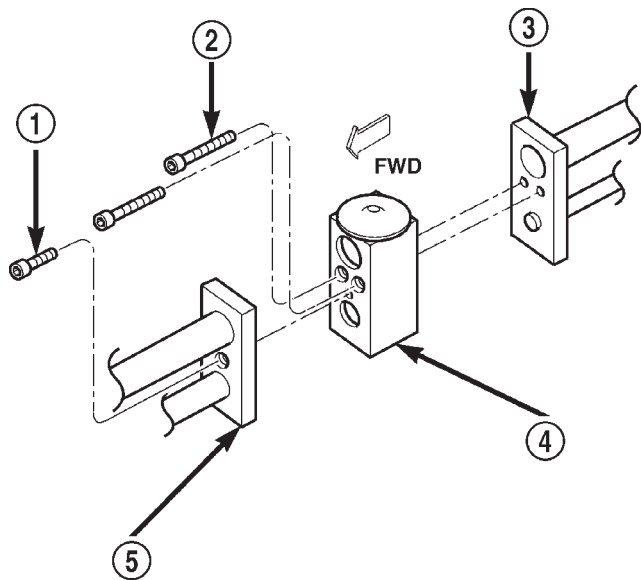

80b3b0aa

**Fig. 57 REAR EXPANSION VALVE REMOVAL/
INSTALL**

- 1 - SCREW
- 2 - SCREW (2)
- 3 - REAR UNDERBODY LINE MOUNTING BLOCK
- 4 - REAR EXPANSION VALVE
- 5 - FRONT UNDERBODY LINE MOUNTING BLOCK

expansion valve ports and stud with the block fitting on the forward lines. Secure with the mounting bolt.

(3) Install the underbody refrigerant lines. See Underbody Refrigerant Line in the Removal and Installation section of this group.

(4) Install the engine air filter housing. Refer to Group 14 - Fuel System for the procedures.

(5) Evacuate and charge the refrigerant system. See Refrigerant System Evacuate in the Service Procedures section of this group.

(6) Connect the battery negative cable.

FILTER-DRIER

WARNING: REVIEW THE WARNINGS AND CAUTIONS IN THE GENERAL INFORMATION SECTION NEAR THE FRONT OF THIS GROUP BEFORE PERFORMING THE FOLLOWING OPERATION.

REMOVAL

(1) Disconnect and isolate the battery negative cable.

(2) Recover the refrigerant from the refrigerant system. See Refrigerant Recovery in the Service Procedures section of this group.

(3) Remove the screws that secure the front and rear liquid line block fittings to the filter-drier inlet

and outlet (Fig. 58). Disengage the block fittings from the filter-drier. Install plugs in, or tape over all of the opened refrigerant line fittings.

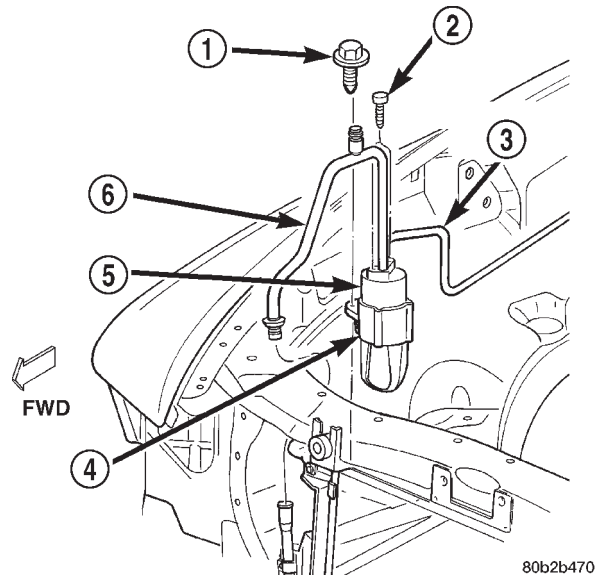

80b2b470

Fig. 58 Filter-Drier Remove/Install

- 1 - SCREW
- 2 - SCREW
- 3 - REAR LIQUID LINE
- 4 - BRACKET
- 5 - FILTER-DRIER
- 6 - FRONT LIQUID LINE

(4) Remove the screw that secures the filter-drier mounting bracket to the front fender wheelhouse front extension.

(5) Remove the filter-drier from the engine compartment.

INSTALLATION

(1) Position the filter-drier and its bracket to the front fender wheelhouse front extension as a unit and loosely secure it with the mounting screw.

(2) Remove the tape or plugs from the front liquid line block fitting and the filter-drier inlet. Install the front liquid line block fitting to the filter-drier inlet and secure the connection with a screw. Tighten the mounting screw to 13.5 N·m (120 in. lbs.).

(3) Remove the tape or plugs from the rear liquid line block fitting and the filter-drier outlet. Install the rear liquid line block fitting to the filter-drier outlet and secure the connection with a screw. Tighten the mounting screw to 13.5 N·m (120 in. lbs.).

(4) Tighten the filter-drier bracket mounting screw to 6.8 N·m (60 in. lbs.).

(5) Connect the battery negative cable.

REMOVAL AND INSTALLATION (Continued)

(6) Evacuate the refrigerant system. See Refrigerant System Evacuate in the Service Procedures section of this group.

(7) Charge the refrigerant system. See Refrigerant System Charge in the Service Procedures section of this group.

NOTE: If the filter-drier is replaced, add 30 milliliters (1 fluid ounce) of refrigerant oil to the refrigerant system. Use only refrigerant oil of the type recommended for the compressor in the vehicle.

HEATER-A/C CONTROL

WARNING: ON VEHICLES EQUIPPED WITH AIR-BAGS, REFER TO GROUP 8M - PASSIVE RESTRAINT SYSTEMS BEFORE ATTEMPTING ANY STEERING WHEEL, STEERING COLUMN, OR INSTRUMENT PANEL COMPONENT DIAGNOSIS OR SERVICE. FAILURE TO TAKE THE PROPER PRECAUTIONS COULD RESULT IN ACCIDENTAL AIR-BAG DEPLOYMENT AND POSSIBLE PERSONAL INJURY.

REMOVAL

(1) Disconnect and isolate the battery negative cable.

(2) Remove the cluster bezel from the instrument panel. Refer to Cluster Bezel in the Removal and Installation section of Group 8E - Instrument Panel Systems for the procedures.

(3) Remove the four screws that secure the heater-A/C control to the instrument panel (Fig. 59).

(4) Pull the heater-A/C control assembly away from the instrument panel far enough to access the connections on the back of the control.

(5) Unplug the wire harness connector from the back of the heater-A/C control (Fig. 60).

(6) Disconnect the wire harness retainer from the side of the heater-A/C control assembly.

(7) Remove the two stamped nuts that secure the vacuum harness connector and unplug the connector from the back of the heater-A/C control.

(8) Release the temperature control cable housing flag retainer latch in the receptacle on the back of the heater-A/C control and disengage the flag retainer from the receptacle.

(9) Rotate the heater-A/C control assembly to align the cable core with the slot on the end of the temperature control lever and disengage the cable end from the lever.

(10) Remove the heater-A/C control from the instrument panel.

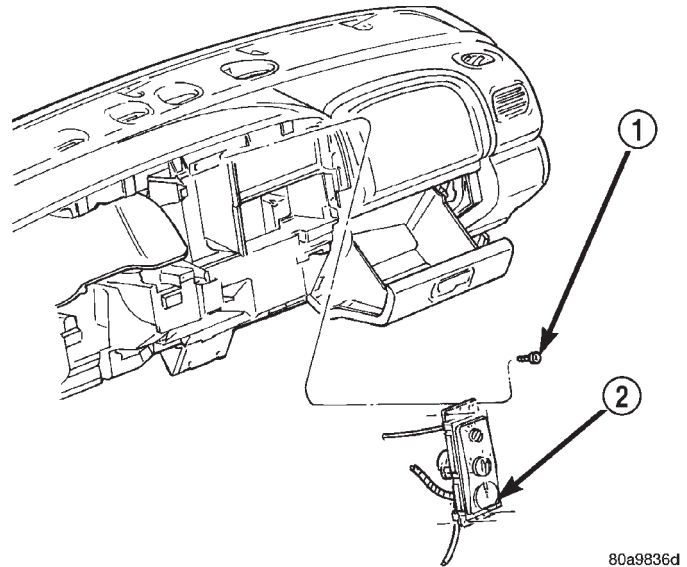

Fig. 59 Heater-A/C Control Remove/Install

- 1 - SCREW
- 2 - CONTROL

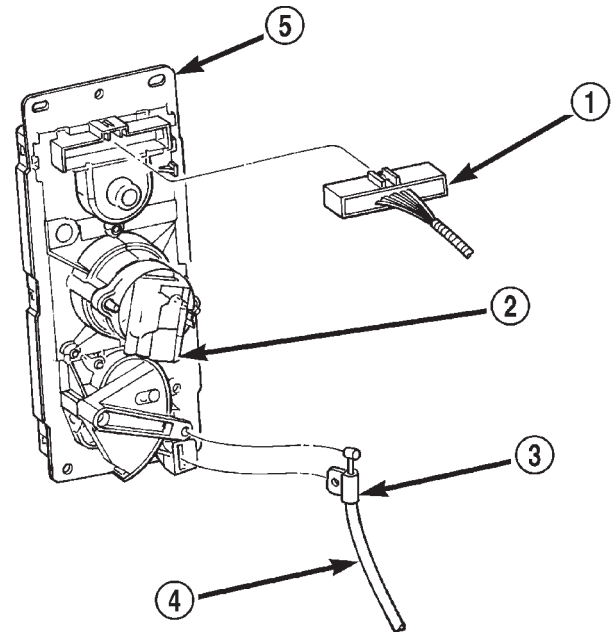

Fig. 60 Heater-A/C Control Connections

- 1 - WIRE HARNESS CONNECTOR
- 2 - VACUUM HARNESS CONNECTOR
- 3 - FLAG RETAINER
- 4 - TEMPERATURE CONTROL CABLE
- 5 - CONTROL

INSTALLATION

(1) Connect the temperature control cable core end to the temperature control lever on the back of the heater-A/C control.

REMOVAL AND INSTALLATION (Continued)

(2) Connect the temperature control cable housing flag retainer to the receptacle on the back of the heater-A/C control.

(3) Plug in the vacuum harness connector and install the two stamped nuts to secure the connector to the back of the heater-A/C control.

(4) Plug the wire harness connector into the back of the heater-A/C control.

(5) Reinstall the wire harness retainer to the side of the heater-A/C control.

(6) Position the heater-A/C control in the instrument panel and secure it with four screws. Tighten the screws to 2.2 N·m (20 in. lbs.).

(7) Reinstall the cluster bezel to the instrument panel. Refer to Cluster Bezel in the Removal and Installation section of Group 8E - Instrument Panel Systems for the procedures.

(8) Connect the battery negative cable.

(9) Adjust the temperature control cable. See Temperature Control Cable in the Adjustments section of this group for the procedures.

HEATER-A/C HOUSING

The heater-A/C housing assembly must be removed from the vehicle and disassembled for service access of the blower motor, blower motor wheel, heater core, evaporator coil, blend-air door, and each of the various mode control doors.

WARNING: REVIEW THE WARNINGS AND CAUTIONS IN THE GENERAL INFORMATION SECTION NEAR THE FRONT OF THIS GROUP BEFORE PERFORMING THE FOLLOWING OPERATION.

WARNING: ON VEHICLES EQUIPPED WITH AIR-BAGS, REFER TO GROUP 8M - PASSIVE RESTRAINT SYSTEMS BEFORE ATTEMPTING ANY STEERING WHEEL, STEERING COLUMN, OR INSTRUMENT PANEL COMPONENT DIAGNOSIS OR SERVICE. FAILURE TO TAKE THE PROPER PRECAUTIONS COULD RESULT IN ACCIDENTAL AIR-BAG DEPLOYMENT AND POSSIBLE PERSONAL INJURY.

REMOVAL

(1) Disconnect and isolate the battery negative cable.

(2) Remove the instrument panel from the vehicle. Refer to Instrument Panel Assembly in the Removal and Installation section of Group 8E - Instrument Panel Systems for the procedures.

(3) Recover the refrigerant from the refrigerant system. See Refrigerant Recovery in the Service Procedures section of this group.

(4) Remove the front expansion valve from the evaporator tube mounting flange. See Expansion Valve in the Removal and Installation section of this group for the procedures. Install plugs in, or tape over all of the opened refrigerant line fittings.

(5) Drain the engine cooling system. Refer to Group 7 - Cooling System for the procedures.

(6) Disconnect the heater hoses from the heater core tubes. Refer to Group 7 - Cooling System for the procedures. Install plugs in, or tape over the opened heater core tubes.

(7) Remove the four nuts from the heater-A/C housing mounting studs on the engine compartment side of the dash panel (Fig. 61).

(8) Disengage the front floor panel transmission tunnel duct from the adapter on the heater-A/C housing.

(9) Remove the nut that secures the heater-A/C housing mounting brace to the stud on the passenger compartment side of the dash panel.

(10) Pull the heater-A/C housing rearward far enough for the mounting studs and the evaporator condensate drain tube to clear the dash panel holes.

(11) Remove the heater-A/C housing from the vehicle.

DISASSEMBLY

(1) Place the heater-A/C housing on a work bench, with the heater-A/C housing cover facing down.

(2) Remove the two screws that secure the heater-A/C housing cover to the top of the blower motor housing cover.

(3) If the vehicle is so equipped, unplug the two vacuum harness connectors from the recirculation air door actuator.

(4) Unplug the vacuum harness connector from the panel-defrost door actuator.

(5) Remove the four screws that secure the floor duct to the bottom of the heater-A/C housing and remove the duct from the housing.

(6) Remove the two screws that secure the heater-A/C housing cover to the lower housing near the floor outlet (Fig. 62).

(7) Turn the heater-A/C housing over on the work bench, with the heater-A/C housing cover facing up.

(8) Disengage the vacuum harness retainer from the hole near the left end of the heater-A/C housing cover.

(9) Remove the vacuum harness from the molded clips on the heater-A/C housing cover (Fig. 63).

(10) Remove the thirteen screws that secure the perimeter of the housing cover to the heater-A/C housing.

(11) Remove the nut that secures the blend-air door lever to the blend-air door pivot shaft and remove the lever.

REMOVAL AND INSTALLATION (Continued)

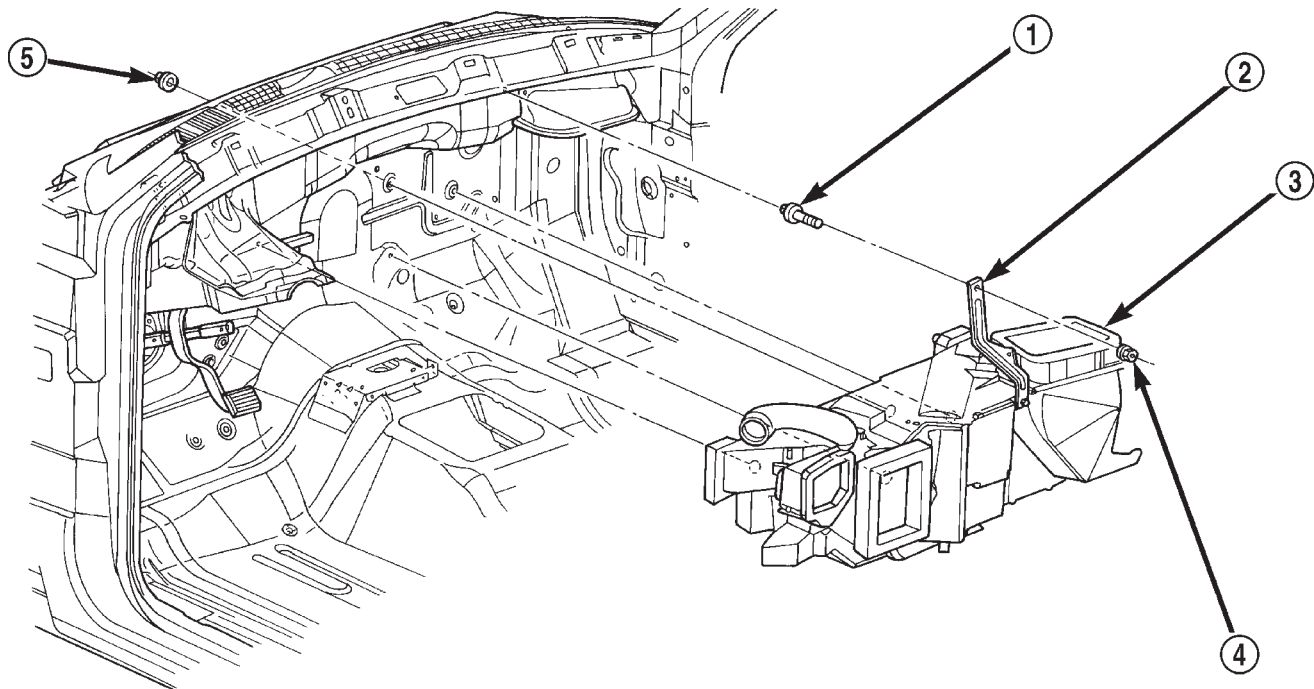
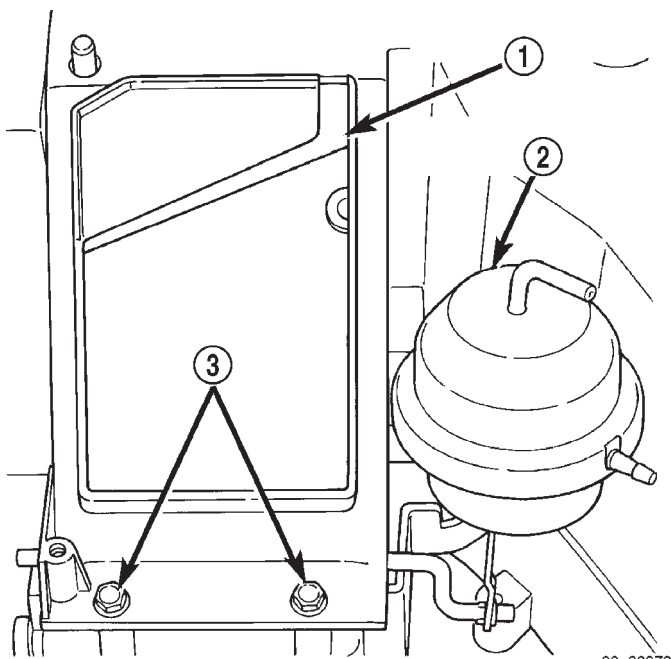

Fig. 61 Heater-A/C Housing Remove/Install

80a89407

- | | |
|------------------------|---------|
| 1 - STUD | 4 - NUT |
| 2 - BRACE | 5 - NUT |
| 3 - HEATER-A/C HOUSING | |



80a98379

Fig. 62 Heater-A/C Housing Floor Outlet Screws

- | |
|-------------------------------------|
| 1 - HEATER-A/C HOUSING FLOOR OUTLET |
| 2 - FLOOR-DEFROST DOOR ACTUATOR |
| 3 - SCREWS |

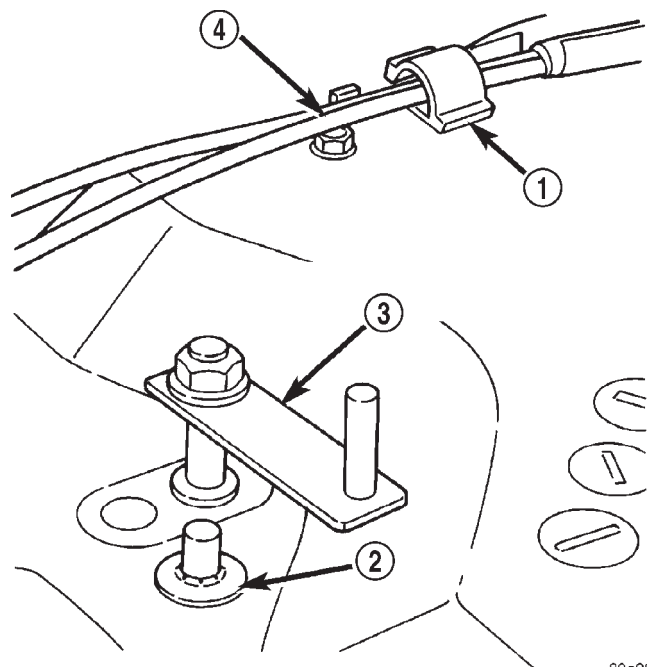

80a9837a

Fig. 63 Blend-Air Door Lever Remove/Install

- | |
|--------------------------|
| 1 - CLIP |
| 2 - PUSH NUT |
| 3 - BLEND-AIR DOOR LEVER |
| 4 - VACUUM HARNESS |

REMOVAL AND INSTALLATION (Continued)

(12) Gently pry off the push nut that secures the heater-A/C housing cover to the heater-A/C housing post.

(13) Using a trim stick or another suitable wide flat-bladed tool, gently pry the panel-defrost door lever off of the panel-defrost door pivot shaft (Fig. 64).

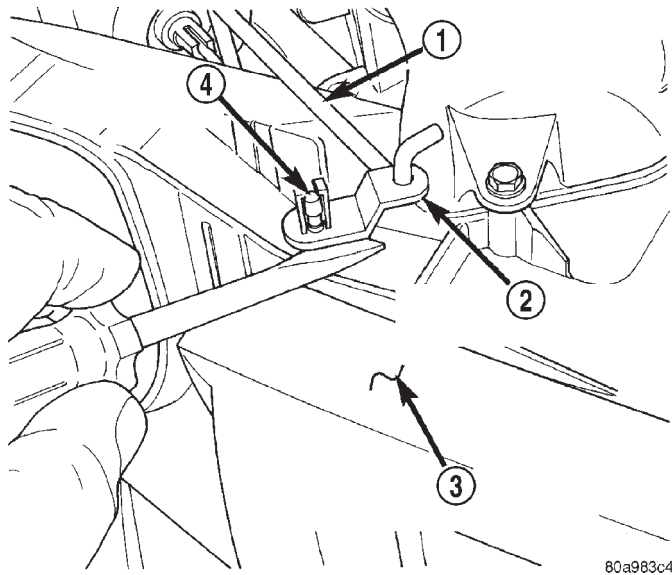

Fig. 64 Panel-Defrost Door Lever Remove

- 1 - PANEL-DEFROST DOOR ACTUATOR LINK
- 2 - PANEL-DEFROST DOOR LEVER
- 3 - HEATER-A/C HOUSING TOP COVER
- 4 - DOOR PIVOT SHAFT

(14) Pull up the perimeter edges of the heater-A/C housing cover far enough to separate the cover sealant from the heater-A/C housing.

(15) Remove the housing cover from the heater-A/C housing.

(16) If the vehicle is so equipped, remove the recirculation air door actuator from the blower motor housing cover. See Mode Door Vacuum Actuators in the Removal and Installation section of this group for the procedures.

(17) Remove the six screws that secure the blower motor housing cover to the heater-A/C housing (Fig. 65).

(18) Remove the blower motor housing cover from the heater-A/C housing.

ASSEMBLY

(1) Before installing the blower motor housing cover, be certain that the cover sealant is in place and in good condition (Fig. 66).

(2) Position the blower motor housing cover to the heater-A/C housing.

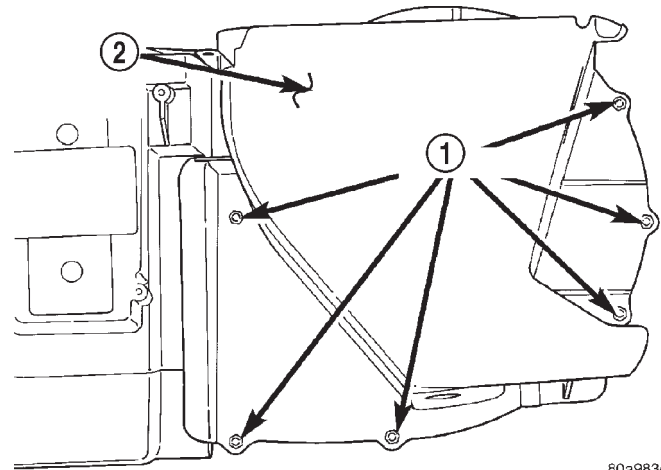

80a983c1

Fig. 65 Blower Motor Housing Cover Remove/Install

- 1 - SCREWS
- 2 - BLOWER MOTOR HOUSING COVER

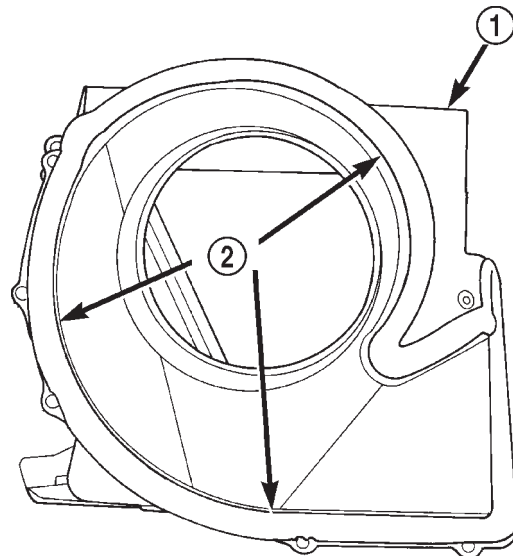

80a98372

Fig. 66 Blower Motor Housing Cover Sealant

- 1 - BLOWER MOTOR HOUSING COVER
- 2 - SEALANT

(3) Install the six screws that secure the blower motor housing cover to the heater-A/C housing. Tighten the screws to 2.2 N·m (20 in. lbs.).

(4) If the vehicle is so equipped, reinstall the recirculation air door actuator. See Mode Door Vacuum Actuators in the Removal and Installation section of this group for the procedures.

(5) Before installing the heater-A/C housing cover, be certain that the cover sealant is in place and in good condition (Fig. 67).

(6) Position the heater-A/C housing cover on the heater-A/C housing. Be certain that the pivots for the

REMOVAL AND INSTALLATION (Continued)

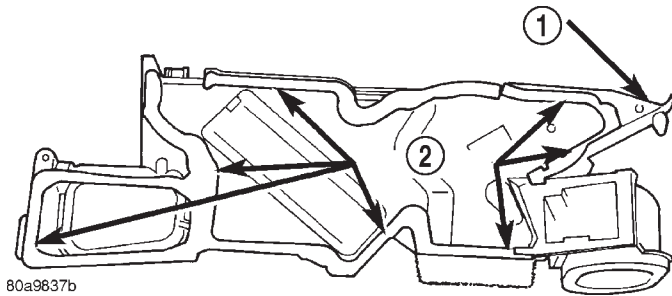

Fig. 67 Heater-A/C Housing Cover Sealant

- 1 - HEATER-A/C HOUSING COVER
2 - SEALANT

floor-defrost, the panel-defrost, the blend-air, and the recirculation air (if the vehicle is so equipped) doors are properly positioned.

(7) Reinstall the push nut that secures the heater-A/C housing cover to the heater-A/C housing post.

(8) Install the thirteen screws that secure the perimeter of the housing cover to the heater-A/C housing. Tighten the screws to 2.2 N·m (20 in. lbs.).

(9) Snap the panel-defrost door lever onto the panel-defrost door pivot shaft.

(10) Install the blend-air door lever to the blend-air door pivot shaft and secure it to the shaft with the nut.

(11) Install the vacuum harness retainer into the hole near the left end of the heater-A/C housing cover.

(12) Route the vacuum harness through the molded clips on the heater-A/C housing cover.

(13) Turn the heater-A/C housing over on the work bench, with the heater-A/C housing cover facing down.

(14) Install the two screws that secure the heater-A/C housing cover to the lower housing near the floor outlet. Tighten the screws to 2.2 N·m (20 in. lbs.).

(15) Position the floor duct to the bottom of the heater-A/C housing and secure with four screws. Tighten the screws to 2.2 N·m (20 in. lbs.).

(16) Plug in the vacuum harness connector to the panel-defrost door actuator.

(17) If the vehicle is so equipped, plug in the two vacuum harness connectors to the recirculation air door actuator.

(18) Install the two screws that secure the heater-A/C housing cover to the top of the blower motor housing cover. Tighten the screws to 2.2 N·m (20 in. lbs.).

(19) Reinstall the heater-A/C housing in the vehicle.

INSTALLATION

(1) Position the heater-A/C housing to the dash panel. Be certain that the evaporator condensate

drain tube and the housing mounting studs are inserted into their correct mounting holes.

(2) Install the nut that secures the heater-A/C housing mounting brace to the stud on the passenger compartment side of the dash panel. Tighten the nut to 11 N·m (95 in. lbs.).

(3) Engage the front floor panel transmission tunnel duct with the adapter on the heater-A/C housing.

(4) Install and tighten the four nuts onto the heater-A/C housing mounting studs on the engine compartment side of the dash panel. Tighten the nuts to 7 N·m (60 in. lbs.).

(5) Unplug or remove the tape from the heater core tubes. Connect the heater hoses to the heater core tubes and fill the engine cooling system. Refer to Group 7 - Cooling System for the procedures.

(6) Reinstall the front expansion valve to the evaporator tube mounting flange. See Expansion Valve in the Removal and Installation section of this group for the procedures.

(7) Evacuate the refrigerant system. See Refrigerant System Evacuate in the Service Procedures section of this group.

(8) Charge the refrigerant system. See Refrigerant System Charge in the Service Procedures section of this group.

(9) Reinstall the instrument panel in the vehicle. Refer to Instrument Panel Assembly in the Removal and Installation section of Group 8E - Instrument Panel Systems for the procedures.

(10) Connect the battery negative cable.

(11) Start the engine and check for proper operation of the heating and air conditioning systems.

HEATER-A/C HOUSING DOOR

WARNING: ON VEHICLES EQUIPPED WITH AIR-BAGS, REFER TO GROUP 8M - PASSIVE RESTRAINT SYSTEMS BEFORE ATTEMPTING ANY STEERING WHEEL, STEERING COLUMN, OR INSTRUMENT PANEL COMPONENT DIAGNOSIS OR SERVICE. FAILURE TO TAKE THE PROPER PRECAUTIONS COULD RESULT IN ACCIDENTAL AIR-BAG DEPLOYMENT AND POSSIBLE PERSONAL INJURY.

BLEND-AIR DOOR

(1) Remove the heater-A/C housing from the vehicle, and remove the housing cover. See Heater-A/C Housing in the Removal and Installation section of this group for the procedures.

(2) Lift the blend-air door pivot shaft out of the pivot hole in the bottom of the heater-A/C housing (Fig. 68).

(3) Reverse the removal procedures to install.

REMOVAL AND INSTALLATION (Continued)

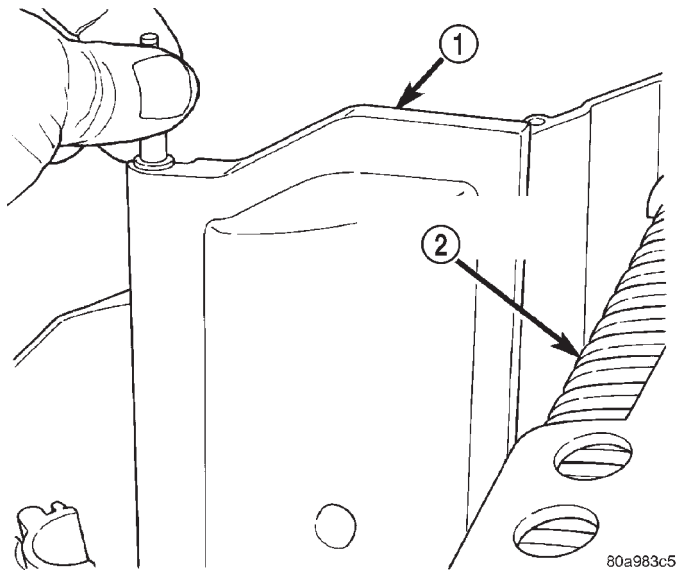
**Fig. 68 Blend-Air Door Remove/Install**

- 1 - BLEND-AIR DOOR
- 2 - EVAPORATOR COIL

FLOOR-DEFROST DOOR

(1) Remove the heater-A/C housing from the vehicle, and remove the housing cover. See Heater-A/C Housing in the Removal and Installation section of this group for the procedures.

(2) Remove the push nut retainer that secures the floor-defrost door actuator link to the floor-defrost door crank arm (Fig. 69).

(3) Disengage the floor-defrost door actuator link from the floor-defrost door crank arm.

(4) Remove the floor-defrost door from the heater-A/C housing.

(5) Reverse the removal procedures to install.

PANEL-DEFROST DOOR

(1) Remove the heater-A/C housing from the vehicle, and remove the housing cover. See Heater-A/C Housing in the Removal and Installation section of this group for the procedures.

(2) Lift the panel-defrost door out of the heater-A/C housing. **Assure that the chute assembly on the panel-defrost door is properly positioned.**

(3) Reverse the removal procedures to install.

RECIRCULATION AIR DOOR

A recirculation air door and vacuum actuator are used only on models with the optional air conditioning system.

(1) Remove the heater-A/C housing from the vehicle, and remove the housing cover. See Heater-A/C Housing in the Removal and Installation section of this group for the procedures.

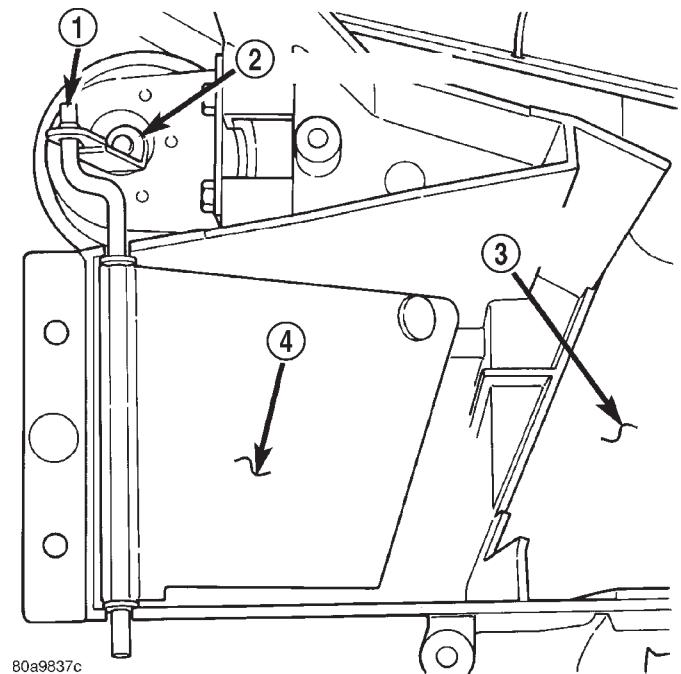
**Fig. 69 Floor-Defrost Door Remove/Install**

- 1 - PUSH-NUT
- 2 - ACTUATOR LINK
- 3 - HEATER-A/C HOUSING
- 4 - FLOOR-DEFROST DOOR

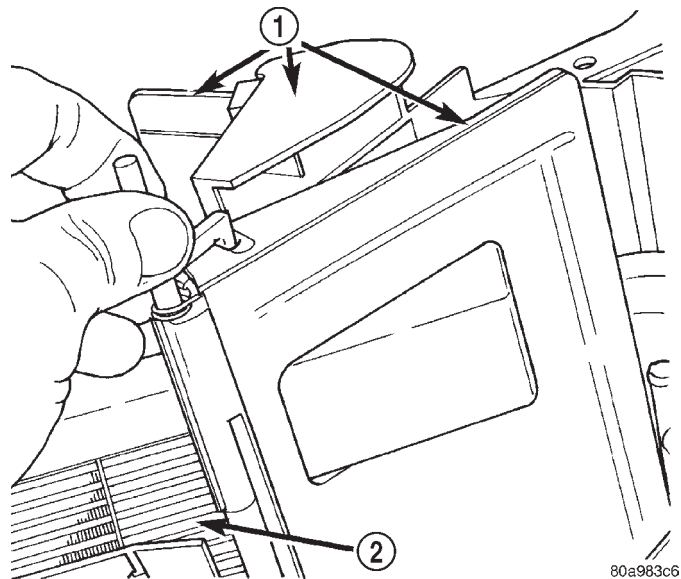
**Fig. 70 Panel-Defrost Door Remove/Install**

- 1 - PANEL-DEFROST DOOR
- 2 - HEATER CORE

(2) Remove the recirculation air door actuator from the blower motor housing cover. See Mode Door Vacuum Actuators in the Removal and Installation section of this group for the procedures.

REMOVAL AND INSTALLATION (Continued)

(3) Lift the lower end of the recirculation air door up far enough so that the door lever is clear of the recirculation air intake grille, then twist the door to remove the door pivots from the pivot holes in the blower motor housing cover (Fig. 71).

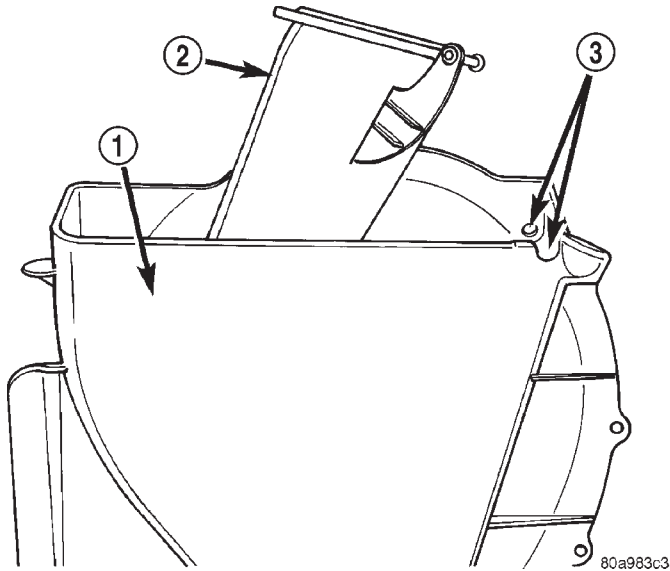

Fig. 71 Recirculation Air Door Remove/Install

- 1 - BLOWER MOTOR HOUSING COVER
- 2 - RECIRCULATION AIR DOOR
- 3 - DOOR PIVOT HOLES

(4) Remove the recirculation air door from the blower motor housing cover.

(5) Reverse the removal procedures to install.

HEATER CORE

WARNING: ON VEHICLES EQUIPPED WITH AIR-BAGS, REFER TO GROUP 8M - PASSIVE RESTRAINT SYSTEMS BEFORE ATTEMPTING ANY STEERING WHEEL, STEERING COLUMN, OR INSTRUMENT PANEL COMPONENT DIAGNOSIS OR SERVICE. FAILURE TO TAKE THE PROPER PRECAUTIONS COULD RESULT IN ACCIDENTAL AIR-BAG DEPLOYMENT AND POSSIBLE PERSONAL INJURY.

REMOVAL

(1) Remove the heater-A/C housing from the vehicle, and remove the housing cover. See Heater-A/C Housing in the Removal and Installation section of this group for the procedures.

(2) Lift the heater core out of the heater-A/C housing (Fig. 72).

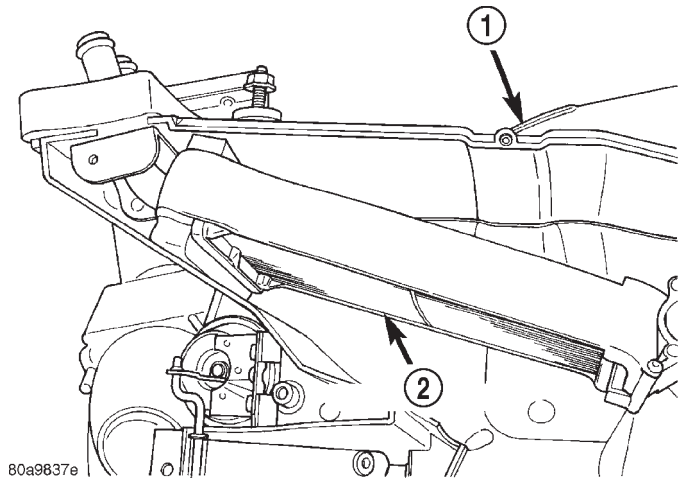

Fig. 72 Heater Core Remove/Install

- 1 - HEATER-A/C HOUSING
- 2 - HEATER CORE

INSTALLATION

(1) Insert the heater core into the bottom of the heater-A/C housing.

(2) Reassemble and reinstall the heater-A/C housing in the vehicle. See Heater-A/C Housing in the Removal and Installation section of this group for the procedures.

HIGH PRESSURE CUT-OFF SWITCH

REMOVAL

(1) Disconnect and isolate the battery negative cable.

(2) Unplug the wire harness connector from the high pressure cut-off switch, which is mounted to a fitting on the discharge line between the compressor and the condenser inlet (Fig. 73).

(3) Unscrew the high pressure cut-off switch from the discharge line fitting.

(4) Remove the high pressure cut-off switch from the vehicle.

(5) Remove the O-ring seal from the discharge line fitting and discard.

INSTALLATION

(1) Lubricate a new O-ring seal with clean refrigerant oil and install it on the discharge line fitting. Use only the specified O-rings as they are made of a special material for the R-134a system. Use only refrigerant oil of the type recommended for the compressor in the vehicle.

(2) Install and tighten the high pressure cut-off switch on the discharge line fitting.

(3) Plug the wire harness connector into the high pressure cut-off switch.

(4) Connect the battery negative cable.

REMOVAL AND INSTALLATION (Continued)

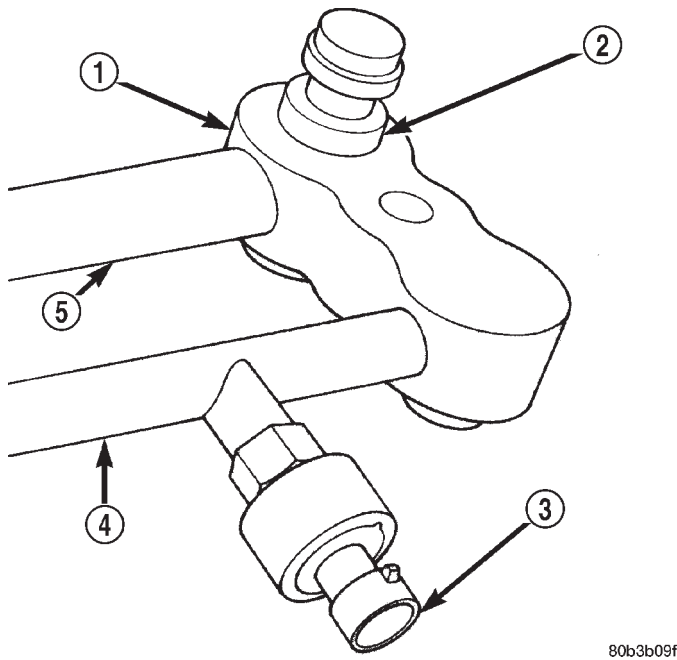

80b3b09f

Fig. 73 High Pressure Cut-Off Switch Remove/Install

- 1 - MANIFOLD
- 2 - LOW PRESSURE SERVICE PORT
- 3 - HIGH PRESSURE CUT-OFF SWITCH
- 4 - DISCHARGE LINE
- 5 - SUCTION LINE

LIQUID LINE

Any kinks or sharp bends in the refrigerant plumbing will reduce the capacity of the entire air conditioning system. Kinks and sharp bends reduce the flow of refrigerant in the system. High pressures are produced in the refrigerant system when the air conditioning compressor is operating. Extreme care must be exercised to make sure that each of the refrigerant system connections is pressure-tight and leak free.

WARNING: REVIEW THE WARNINGS AND CAUTIONS IN THE GENERAL INFORMATION SECTION NEAR THE FRONT OF THIS GROUP BEFORE PERFORMING THE FOLLOWING OPERATION.

FRONT**REMOVAL**

- (1) Disconnect and isolate the battery negative cable.
- (2) Recover the refrigerant from the refrigerant system. See Refrigerant Recovery in the Service Procedures section of this group.
- (3) Remove the screw that secures the front liquid line block fitting to the inlet of the filter-drier, and disengage the fitting from the filter-drier (Fig. 74).

Install plugs in, or tape over all of the opened refrigerant line fittings.

(4) Disconnect the front liquid line refrigerant line coupler at the condenser outlet. See Refrigerant Line Coupler in the Removal and Installation section of this group for the procedures. Install plugs in, or tape over all of the opened refrigerant line fittings.

(5) Remove the front liquid line from the engine compartment.

INSTALLATION

(1) Remove the tape or plugs from the refrigerant line fittings on the front liquid line and the condenser outlet. Connect the front liquid line to the condenser outlet. See Refrigerant Line Coupler in the Removal and Installation section of this group for the procedures.

(2) Remove the tape or plugs from the front liquid line block fitting and the filter-drier inlet. Install the front liquid line block fitting to the filter-drier inlet and secure the connection with a screw. Tighten the mounting screw to 13.5 N·m (120 in. lbs.).

(3) Connect the battery negative cable.

(4) Evacuate the refrigerant system. See Refrigerant System Evacuate in the Service Procedures section of this group.

(5) Charge the refrigerant system. See Refrigerant System Charge in the Service Procedures section of this group.

REAR**REMOVAL**

(1) Disconnect and isolate the battery negative cable.

(2) Recover the refrigerant from the refrigerant system. See Refrigerant Recovery in the Service Procedures section of this group.

(3) Remove the engine air filter housing. Refer to Group 14 - Fuel System for the procedures.

(4) Remove the nut that secures the ground strap to the inboard side of the rear liquid line block fitting.

(5) Remove the screw that secures the rear liquid line block fitting to the outlet of the filter-drier, and disengage the fitting from the filter-drier. Install plugs in, or tape over all of the opened refrigerant line fittings.

(6) Disconnect the suction line from the suction jumper. See refrigerant line coupler in the removal and installation section.

(7) If the vehicle is equipped with the optional rear overhead A/C unit, disconnect the refrigerant line couplers near the dash panel between the suction line jumper and the rear liquid line extension and both of the underbody refrigerant lines. See Refrigerant

REMOVAL AND INSTALLATION (Continued)

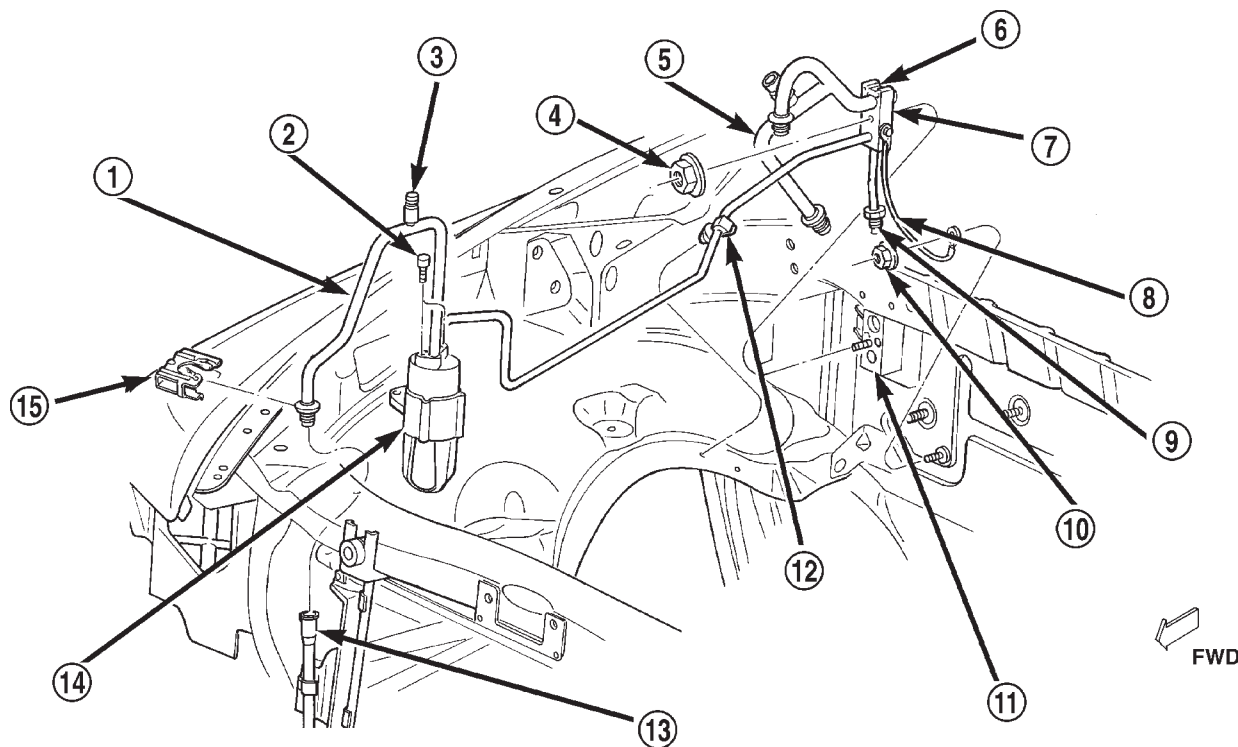

80b11cef

Fig. 74 Liquid Line Remove/Install

- | | |
|--------------------------------|---------------------------|
| 1 - FRONT LIQUID LINE | 9 - LIQUID LINE EXTENSION |
| 2 - SCREW | 10 - NUT |
| 3 - HIGH PRESSURE SERVICE PORT | 11 - EXPANSION VALVE |
| 4 - NUT | 12 - CLIP |
| 5 - SUCTION LINE JUMPER | 13 - CONDENSER OUTLET |
| 6 - PLASTIC RETAINER | 14 - FILTER-DRIER |
| 7 - REAR LIQUID LINE | 15 - CLIP |
| 8 - GROUND STRAP | |

ant Line Coupler in the Removal and Installation section of this group for the procedures. Install plugs in, or tape over all of the opened refrigerant line fittings.

(8) Disengage the clip that secures the rear liquid line to the inner fender shield.

(9) Remove the nut that secures the rear liquid line block fitting to the stud on the expansion valve, and disengage the fitting from the expansion valve. Install plugs in, or tape over all of the opened refrigerant line fittings.

(10) Remove the rear liquid line from the engine compartment.

(11) Remove the suction line jumper from the rear liquid line block fitting. See Suction Line Jumper in the Removal and Installation section of this group for the procedures.

INSTALLATION

(1) Install the suction line jumper into the rear liquid line block fitting. See Suction Line Jumper in the

Removal and Installation section of this group for the procedures.

(2) Remove the tape or plugs from the rear liquid line block fitting and the expansion valve. Install the rear liquid line block fitting over the expansion valve stud and secure the connection with a nut. Tighten the mounting nut to 22.5 N·m (200 in. lbs.).

(3) Install the rear liquid line in the clip on the inner fender shield.

(4) If the vehicle is equipped with the optional rear overhead A/C unit, remove the tape or plugs from the refrigerant line fittings on the suction line jumper and the rear liquid line extension and both of the underbody refrigerant lines. Connect the underbody refrigerant lines to the suction line jumper and the rear liquid line extension. See Refrigerant Line Coupler in the Removal and Installation section of this group for the procedures.

(5) Remove the tape or plugs from the rear liquid line block fitting and the filter-drier outlet. Install the rear liquid line block fitting to the filter-drier

REMOVAL AND INSTALLATION (Continued)

outlet and secure the connection with a screw. Tighten the mounting screw to 13.5 N·m (120 in. lbs.). Connect the suction line from the suction discharge assembly to the suction jumper tube.

(6) Reinstall the nut that secures the ground strap to the inboard side of the rear liquid line block fitting. Tighten the mounting screw to 6.8 N·m (60 in. lbs.).

(7) Reinstall the engine air filter housing. Refer to Group 14 - Fuel System for the procedures.

(8) Connect the battery negative cable.

(9) Evacuate the refrigerant system. See Refrigerant System Evacuate in the Service Procedures section of this group.

(10) Charge the refrigerant system. See Refrigerant System Charge in the Service Procedures section of this group.

LOW PRESSURE CUT-OFF SWITCH

REMOVAL

(1) Disconnect and isolate the battery negative cable.

(2) Unplug the wire harness connector from the low pressure cut-off switch on the suction line jumper near the expansion valve (Fig. 75).

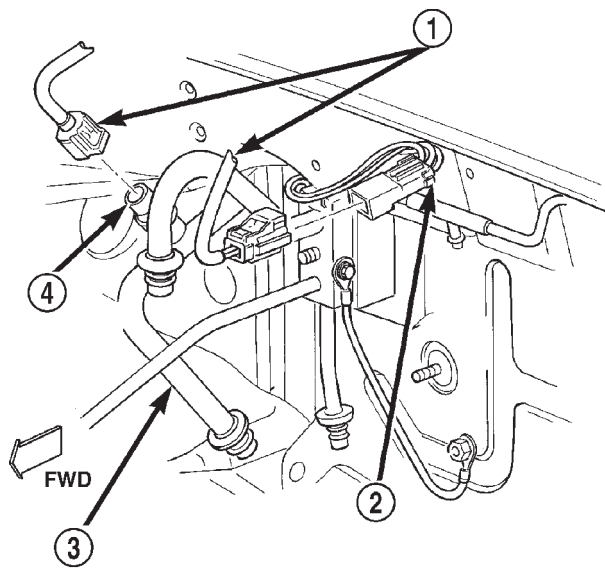

80b2b463

Fig. 75 Low Pressure Cut-Off Switch Remove/Install

- 1 - WIRE HARNESS CONNECTORS
- 2 - TO ELECTRONIC CYCLING CLUTCH SWITCH
- 3 - SUCTION LINE JUMPER
- 4 - LOW PRESSURE CUT-OFF SWITCH

(3) Unscrew the low pressure cut-off switch from the fitting on the suction line jumper.

(4) Remove the O-ring seal from the suction line jumper fitting and discard.

INSTALLATION

(1) Lubricate a new O-ring seal with clean refrigerant oil and install it on the suction line jumper fitting. Use only the specified O-rings as they are made of a special material for the R-134a system. Use only refrigerant oil of the type recommended for the compressor in the vehicle.

(2) Install and tighten the low pressure cut-off switch on the suction line jumper fitting. The switch should be hand-tightened onto the fitting.

(3) Plug the wire harness connector into the low pressure cut-off switch.

(4) Connect the battery negative cable.

MODE DOOR VACUUM ACTUATOR

WARNING: ON VEHICLES EQUIPPED WITH AIR-BAGS, REFER TO GROUP 8M - PASSIVE RESTRAINT SYSTEMS BEFORE ATTEMPTING ANY STEERING WHEEL, STEERING COLUMN, OR INSTRUMENT PANEL COMPONENT DIAGNOSIS OR SERVICE. FAILURE TO TAKE THE PROPER PRECAUTIONS COULD RESULT IN ACCIDENTAL AIR-BAG DEPLOYMENT AND POSSIBLE PERSONAL INJURY.

FLOOR-DEFROST DOOR ACTUATOR

(1) Disconnect and isolate the battery negative cable.

(2) Remove the instrument panel assembly from the vehicle. Refer to Instrument Panel Assembly in the Removal and Installation section of Group 8E - Instrument Panel Systems for the procedures.

(3) Unplug the two vacuum harness connectors from the floor-defrost door actuator (Fig. 76).

(4) Remove the push nut retainer that secures the floor-defrost door actuator link to the floor-defrost door crank arm.

(5) Remove the two screws that secure the floor-defrost door actuator to the heater-A/C housing.

(6) Disengage the floor-defrost door actuator link from the floor-defrost door crank arm and remove the actuator from the heater-A/C housing.

(7) Reverse the removal procedures to install. Tighten the floor-defrost door actuator mounting screws to 2.2 N·m (20 in. lbs.).

PANEL-DEFROST DOOR ACTUATOR

(1) Disconnect and isolate the battery negative cable.

(2) Remove the instrument panel assembly from the vehicle. Refer to Instrument Panel Assembly in

REMOVAL AND INSTALLATION (Continued)

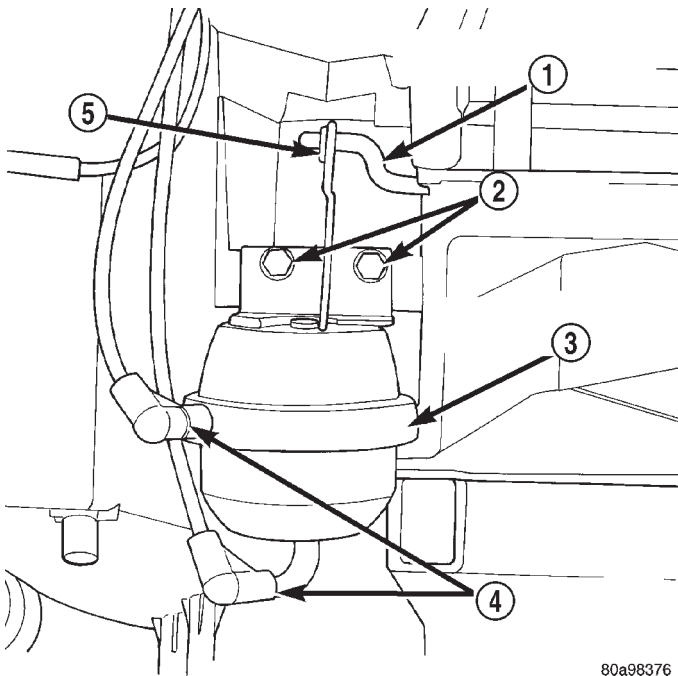

80a98376

Fig. 76 Floor-Defrost Door Actuator Remove/Install

- 1 - FLOOR-DEFROST DOOR CRANK ARM
- 2 - SCREWS
- 3 - FLOOR-DEFROST DOOR ACTUATOR
- 4 - VACUUM CONNECTORS
- 5 - PUSH NUT

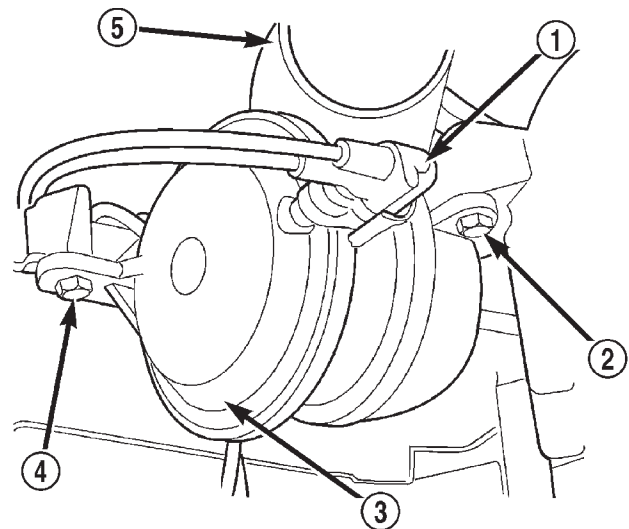

80a98375

Fig. 77 Panel-Defrost Door Actuator

- 1 - VACUUM CONNECTOR
- 2 - SCREW
- 3 - PANEL-DEFROST DOOR ACTUATOR
- 4 - SCREW
- 5 - DEMISTER DUCT ADAPTER

the Removal and Installation section of Group 8E - Instrument Panel Systems for the procedures.

(3) Unplug the vacuum harness connector from the panel-defrost door actuator (Fig. 77).

(4) Remove the two screws that secure the panel-defrost door actuator to the heater-A/C housing.

(5) Rotate the panel-defrost door actuator clockwise about one-quarter turn to disengage the hooked end of the actuator link from the hole on the end of the panel-defrost door lever.

(6) Remove the panel-defrost door actuator from the heater-A/C housing.

(7) Reverse the removal procedures to install. Tighten the panel-defrost door actuator mounting screws to 2.2 N·m (20 in. lbs.).

RECIRCULATION AIR DOOR ACTUATOR

A recirculation air door and vacuum actuator are used only on models with the optional air conditioning system.

(1) Disconnect and isolate the battery negative cable.

(2) Remove the instrument panel assembly from the vehicle. Refer to Instrument Panel Assembly in the Removal and Installation section of Group 8E - Instrument Panel Systems for the procedures.

(3) If the vehicle is so equipped, and the heater-A/C housing is in its installed position in the vehicle, remove the Infinity speaker system amplifier. Refer to Amplifier in the Removal and Installation section of Group 8F - Audio Systems for the procedures.

(4) Unplug the two vacuum harness connectors from the recirculation air door actuator (Fig. 78).

(5) Remove the two stamped nuts that secure the recirculation air door actuator to the blower motor housing cover.

(6) Unhook the actuator link from the recirculation air door lever.

(7) Remove the actuator from the blower motor housing cover.

(8) Reverse the removal procedures to install. Tighten the mounting nuts until the recirculation air door actuator is seated to the blower motor housing cover.

REAR BLOWER MOTOR SWITCH

The rear blower motor switch is used only on models with the optional rear overhead air conditioning unit.

REMOVAL

(1) Disconnect and isolate the battery negative cable.

(2) Using a trim stick or another suitable wide flat-bladed tool, gently pry above the two indentations at the outer perimeter of the rear blower motor switch to release it from the headliner (Fig. 79).

REMOVAL AND INSTALLATION (Continued)

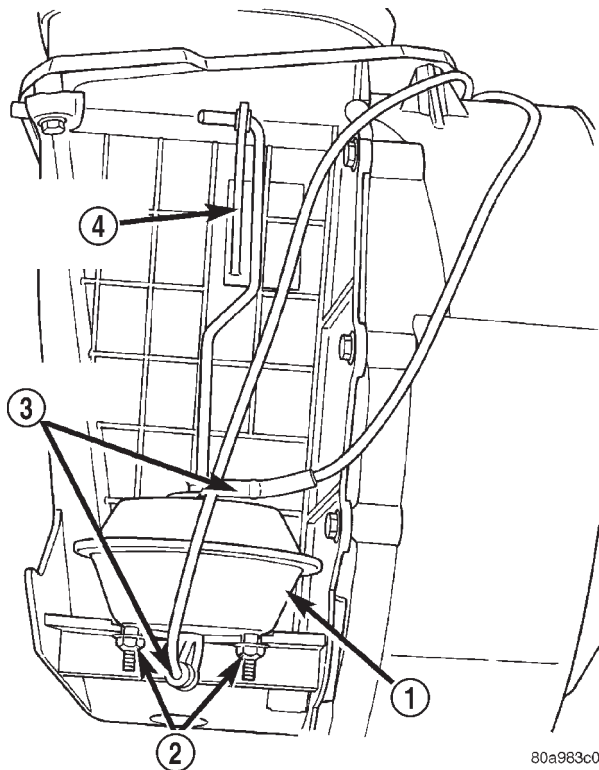

Fig. 78 Recirculation Air Door Actuator Remove/Install

- 1 - ACTUATOR
- 2 - NUTS
- 3 - VACUUM CONNECTORS
- 4 - RECIRCULATION AIR DOOR LEVER

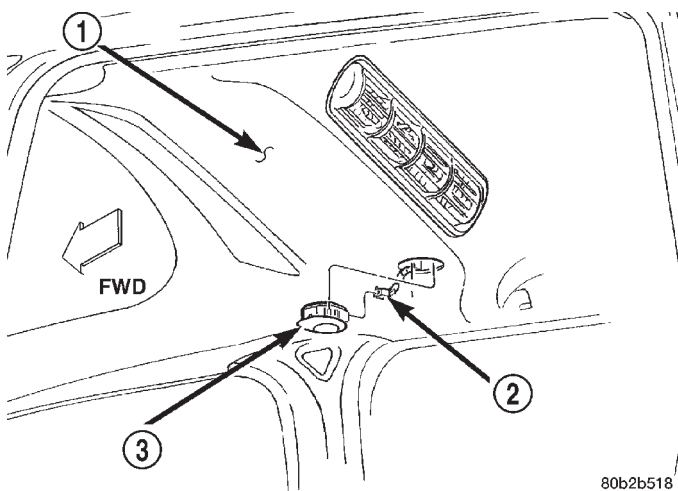

Fig. 79 Rear Blower Motor Switch Remove/Install

- 1 - HEADLINER
- 2 - WIRE HARNESS CONNECTOR
- 3 - REAR BLOWER MOTOR SWITCH

(3) Pull the rear blower motor switch away from the headliner far enough to access and unplug the wire harness connector from the back of the switch.

(4) Remove the rear blower motor switch from the headliner.

INSTALLATION

(1) Plug the wire harness connector into the back of the rear blower motor switch.

(2) Tuck the wire harness back through the rear blower motor switch mounting hole in the headliner.

(3) Gently press the rear blower motor switch into the mounting hole in the headliner until it snaps into place.

(4) Connect the battery negative cable.

REAR OVERHEAD A/C UNIT

WARNING: REVIEW THE WARNINGS AND CAUTIONS IN THE GENERAL INFORMATION SECTION NEAR THE FRONT OF THIS GROUP BEFORE PERFORMING THE FOLLOWING OPERATION.

REMOVAL

(1) Disconnect and isolate the battery negative cable.

(2) Recover the refrigerant from the refrigerant system. See Refrigerant Recovery in the Service Procedures section of this group.

(3) Remove the headliner from the passenger compartment of the vehicle. Refer to Group 23 - Body for the procedures.

(4) From the passenger compartment, remove the nut from the bolt, (suction line) and nut from stud, (liquid line) that secure the block fittings at the top of the B-pillar refrigerant lines on the rear overhead A/C unit, and disengage the fittings (Fig. 80). Install plugs in, or tape over all of the opened refrigerant line fittings.

(5) Disconnect the B-pillar drain hoses from the wye fittings on each side of the rear overhead A/C unit (Fig. 81).

(6) Unplug the rear overhead A/C unit wire harness connector located at the left side of the unit.

(7) Loosen but do not remove the two screws that secure the mounting bracket on the left end of the rear overhead A/C unit to the left roof rail (Fig. 82).

(8) Support the right end of the rear overhead A/C unit while removing the two screws that secure the mounting bracket on the right end of the unit to the right roof rail.

(9) Slide the rear overhead A/C unit towards the right side of the vehicle far enough to disengage the slotted holes on the left end of the mounting bracket from the loosened screws in the left roof rail.

(10) Remove the rear overhead A/C unit from the passenger compartment.

REMOVAL AND INSTALLATION (Continued)

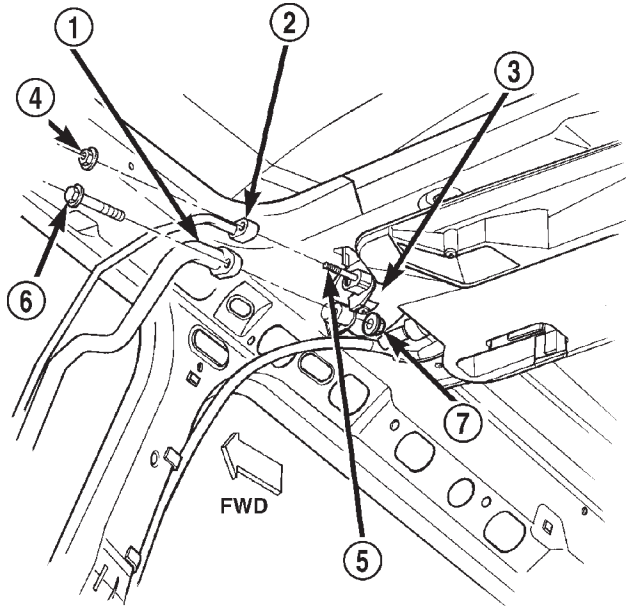

80b3c5eb

Fig. 80 Rear Overhead A/C Unit Refrigerant Line Remove/Install

- 1 - B-PILLAR SUCTION LINE
- 2 - B-PILLAR LIQUID LINE
- 3 - OVERHEAD AIR CONDITIONING UNIT
- 4 - NUT
- 5 - STUD
- 6 - BOLT
- 7 - NUT

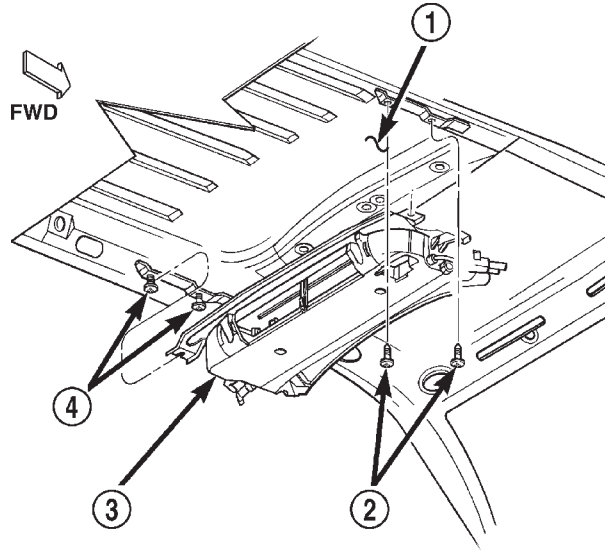

80b9a4c4

Fig. 82 Rear Overhead A/C Unit Remove/Install

- 1 - ROOF PANEL
- 2 - SCREWS
- 3 - REAR OVERHEAD A/C UNIT
- 4 - SCREWS

INSTALLATION

(1) Engage the slotted holes in the left end of rear overhead A/C unit mounting bracket with the loosened screws in the left roof rail.

(2) Support the right end of the rear overhead A/C unit while installing the two screws that secure the mounting bracket on the right end of the unit to the right roof rail. Tighten all of the mounting screws to 11.9 N·m (105 in. lbs.).

(3) Plug in the rear overhead A/C unit wire harness connector located at the left side of the unit.

(4) Connect the B-pillar drain hoses to the wye fittings on each side of the rear overhead A/C unit.

(5) Remove the tape or plugs from block fittings at the top of the B-pillar refrigerant line unit, and from the fittings on the rear overhead A/C unit. Install the B-pillar refrigerant line block fittings over the one stud on the rear overhead A/C unit. Install the bolt holding the suction line, and secure the connections with the mounting nuts. Tighten the mounting nuts to 11.3 N·m (100 in. lbs.).

(6) Reinstall the headliner in the passenger compartment of the vehicle. Refer to Group 23 - Body for the procedures.

(7) Connect the battery negative cable.

(8) Evacuate the refrigerant system. See Refrigerant System Evacuate in the Service Procedures section of this group.

(9) Charge the refrigerant system. See Refrigerant System Charge in the Service Procedures section of this group.

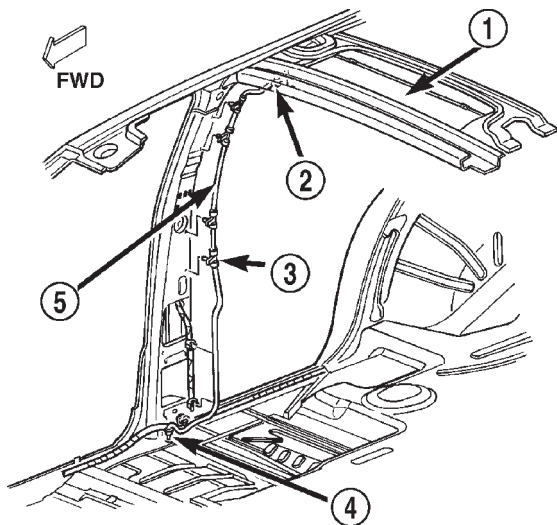

80b2b519

Fig. 81 Rear Overhead A/C Drain Hose Remove/Install

- 1 - REAR OVERHEAD A/C UNIT
- 2 - WYE FITTING
- 3 - CLIP
- 4 - GROMMET
- 5 - DRAIN HOSE

REMOVAL AND INSTALLATION (Continued)

NOTE: If the rear overhead A/C unit is replaced, add 30 milliliters (1 fluid ounce) of refrigerant oil to the refrigerant system. Use only refrigerant oil of the type recommended for the compressor in the vehicle.

REFRIGERANT LINE COUPLER

WARNING: REVIEW THE WARNINGS AND CAUTIONS IN THE GENERAL INFORMATION SECTION NEAR THE FRONT OF THIS GROUP BEFORE PERFORMING THE FOLLOWING OPERATION.

REMOVAL

- (1) Recover the refrigerant from the refrigerant system. See Refrigerant Recovery in the Service Procedures section of this group.
- (2) Remove the secondary clip from the spring-lock coupler.
- (3) Fit the proper size A/C line disconnect tool (Special Tool Kit 7193) over the spring-lock coupler cage (Fig. 83).

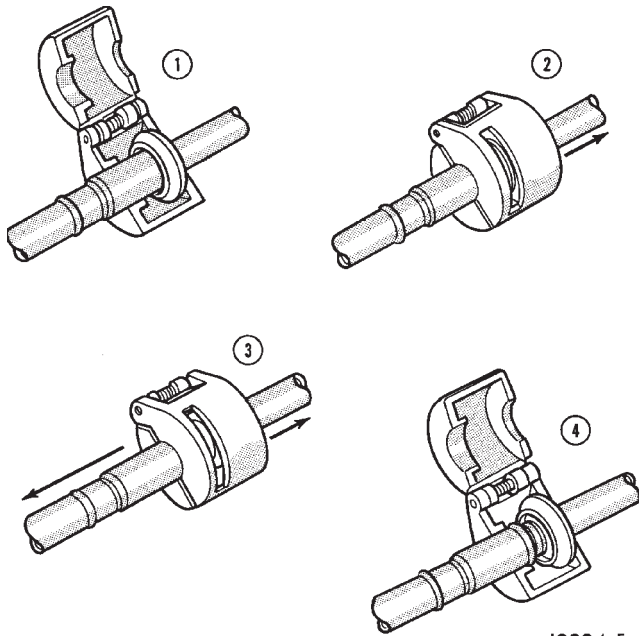

Fig. 83 Refrigerant Line Spring-Lock Coupler Disconnect

- (4) Close the two halves of the A/C line disconnect tool around the spring-lock coupler.
- (5) Push the A/C line disconnect tool into the open side of the coupler cage to expand the garter spring. Once the garter spring is expanded and while still pushing the disconnect tool into the open side of the coupler cage, pull on the refrigerant line attached to the female half of the coupler fitting until the flange on the female fitting is separated from the garter spring and cage on the male fitting within the disconnect tool.

NOTE: The garter spring may not release if the A/C line disconnect tool is cocked while pushing it into the coupler cage opening.

- (6) Open and remove the A/C line disconnect tool from the disconnected spring-lock coupler.
- (7) Complete the separation of the two halves of the coupler fitting.

INSTALLATION

- (1) Check to ensure that the garter spring is located within the cage of the male coupler fitting, and that the garter spring is not damaged.
 - (a) If the garter spring is missing, install a new spring by pushing it into the coupler cage opening.
 - (b) If the garter spring is damaged, remove it from the coupler cage with a small wire hook (DO NOT use a screwdriver) and install a new garter spring.
- (2) Clean any dirt or foreign material from both halves of the coupler fitting.
- (3) Install new O-rings on the male half of the coupler fitting.

CAUTION: Use only the specified O-rings as they are made of a special material for the R-134a system. The use of any other O-rings may allow the connection to leak intermittently during vehicle operation.

- (4) Lubricate the male fitting and O-rings, and the inside of the female fitting with clean R-134a refrigerant oil. Use only refrigerant oil of the type recommended for the compressor in the vehicle.
- (5) Fit the female half of the coupler fitting over the male half of the fitting.
- (6) Push together firmly on the two halves of the coupler fitting until the garter spring in the cage on the male half of the fitting snaps over the flanged end on the female half of the fitting.
- (7) Ensure that the spring-lock coupler is fully engaged by trying to separate the two coupler halves. This is done by pulling the refrigerant lines on either side of the coupler away from each other.
- (8) Reinstall the secondary clip over the spring-lock coupler cage.

SUCTION AND DISCHARGE LINE

Any kinks or sharp bends in the refrigerant plumbing will reduce the capacity of the entire air conditioning system. Kinks and sharp bends reduce the flow of refrigerant in the system. A good rule for the flexible hose refrigerant lines is to keep the radius of all bends at least ten times the diameter of the hose. In addition, the flexible hose refrigerant lines should be routed so they are at least 80 millimeters (3 inches) from the exhaust manifold.

REMOVAL AND INSTALLATION (Continued)

High pressures are produced in the refrigerant system when the air conditioning compressor is operating. Extreme care must be exercised to make sure that each of the refrigerant system connections is pressure-tight and leak free. It is a good practice to inspect all flexible hose refrigerant lines at least once a year to make sure they are in good condition and properly routed.

WARNING: REVIEW THE WARNINGS AND CAUTIONS IN THE GENERAL INFORMATION SECTION NEAR THE FRONT OF THIS GROUP BEFORE PERFORMING THE FOLLOWING OPERATION.

REMOVAL

- (1) Disconnect and isolate the battery negative cable.
- (2) Recover the refrigerant from the refrigerant system. See Refrigerant Recovery in the Service Procedures section of this group.
- (3) Unplug the wire harness connector from the high pressure cut-off switch.
- (4) Disconnect the refrigerant line couplers at the condenser and the suction line jumper. See Refrigerant Line Coupler in the Removal and Installation section of this group for the procedures. Install plugs in, or tape over all of the opened refrigerant line fittings.
- (5) Remove the nut that secures the refrigerant line support bracket near the compressor.
- (6) Remove the screw that secures the refrigerant line manifold to the compressor (Fig. 84). Install plugs in, or tape over all of the opened refrigerant line fittings.
- (7) Remove the suction and discharge line assembly from the vehicle.

INSTALLATION

- (1) Remove the tape or plugs from all of the refrigerant line fittings. Install the refrigerant line couplers to the condenser and the suction line jumper. See Refrigerant Line Coupler in the Removal and Installation section of this group for the procedures.
- (2) Install the refrigerant line manifold to the compressor. Tighten the mounting screw to 22 N·m (200 in. lbs.).
- (3) Install the nut that secures the refrigerant line support bracket near the compressor.
- (4) Plug in the wire harness connector to the high pressure cut-off switch.
- (5) Connect the battery negative cable.
- (6) Evacuate the refrigerant system. See Refrigerant System Evacuate in the Service Procedures section of this group.
- (7) Charge the refrigerant system. See Refrigerant System Charge in the Service Procedures section of this group.

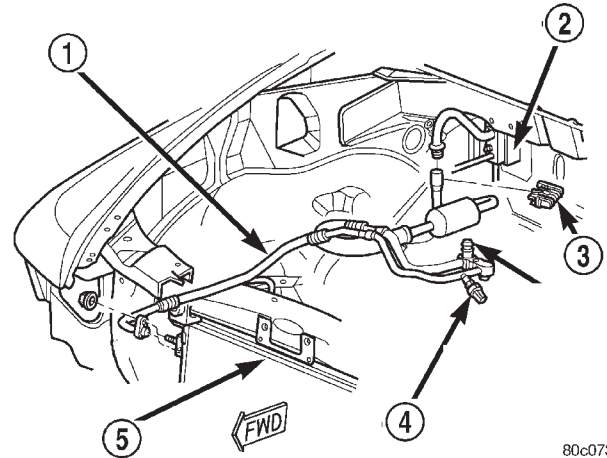

80c0731b

Fig. 84 Suction and Discharge Line Remove/Install

- 1 - SUCTION AND DISCHARGE LINE ASSEMBLY
- 2 - EXPANSION VALVE
- 3 - LINE CLIP
- 4 - LOW PRESSURE SERVICE PORT
- 5 - HIGH PRESSURE CUT-OFF SWITCH
- 6 - CONDENSER

SUCTION LINE JUMPER

Any kinks or sharp bends in the refrigerant plumbing will reduce the capacity of the entire air conditioning system. Kinks and sharp bends reduce the flow of refrigerant in the system. High pressures are produced in the refrigerant system when the air conditioning compressor is operating. Extreme care must be exercised to make sure that each of the refrigerant system connections is pressure-tight and leak free.

WARNING: REVIEW THE WARNINGS AND CAUTIONS IN THE GENERAL INFORMATION SECTION NEAR THE FRONT OF THIS GROUP BEFORE PERFORMING THE FOLLOWING OPERATION.

REMOVAL

- (1) Disconnect and isolate the battery negative cable.
- (2) Remove the low pressure cut-off switch from the fitting on the suction line jumper. See Low Pressure Cut-Off Switch in the Removal and Installation section of this group for the procedures.
- (3) Recover the refrigerant from the refrigerant system. See Refrigerant Recovery in the Service Procedures section of this group.
- (4) Disconnect the refrigerant line coupler between the suction line and the suction line jumper. See Refrigerant Line Coupler in the Removal and Installation section of this group for the procedures. Install plugs in, or tape over all of the opened refrigerant line fittings.

REMOVAL AND INSTALLATION (Continued)

(5) Remove the rear liquid line from the engine compartment. See Liquid Line in the Removal and Installation section of this group for the procedures.

(6) Slide the plastic retainer that secures the suction line jumper out of the saddle formation at the top of the rear liquid line block fitting. Secure block, preferably in a vise. Tap the plastic retainer out with a hammer and flat-bladed screwdriver.

(7) Remove the suction line jumper from the rear liquid line block fitting.

INSTALLATION

(1) Using a new O-ring, install the suction line jumper into the saddle formation at the top of the rear liquid line block fitting.

(2) Slide the plastic retainer that secures the suction line jumper into the rear liquid line block fitting.

(3) Install the rear liquid line into the engine compartment. See Liquid Line in the Removal and Installation section of this group for the procedures.

(4) Remove the tape or plugs from the refrigerant line fittings on the suction line and the suction line jumper. Install the suction line to the suction line jumper. See Refrigerant Line Coupler in the Removal and Installation section of this group for the procedures.

(5) Install the low pressure cut-off switch to the fitting on the suction line jumper. See Low Pressure Cut-Off Switch in the Removal and Installation section of this group for the procedures.

(6) Connect the battery negative cable.

(7) Evacuate the refrigerant system. See Refrigerant System Evacuate in the Service Procedures section of this group.

(8) Charge the refrigerant system. See Refrigerant System Charge in the Service Procedures section of this group.

TEMPERATURE CONTROL CABLE

WARNING: ON VEHICLES EQUIPPED WITH AIR-BAGS, REFER TO GROUP 8M - PASSIVE RESTRAINT SYSTEMS BEFORE ATTEMPTING ANY STEERING WHEEL, STEERING COLUMN, OR INSTRUMENT PANEL COMPONENT DIAGNOSIS OR SERVICE. FAILURE TO TAKE THE PROPER PRECAUTIONS COULD RESULT IN ACCIDENTAL AIR-BAG DEPLOYMENT AND POSSIBLE PERSONAL INJURY.

REMOVAL

(1) Disconnect and isolate the battery negative cable.

(2) Roll down the instrument panel assembly, but do not remove it from the vehicle. Refer to Instrument Panel Assembly in the Removal and Installa-

tion section of Group 8E - Instrument Panel Systems for the procedures.

(3) Disconnect the temperature control cable from the heater-A/C control. See Heater-A/C Control in the Removal and Installation section of this group for the procedures.

(4) Disconnect the temperature control cable housing flag retainer from the receptacle on the top of the heater-A/C housing (Fig. 85).

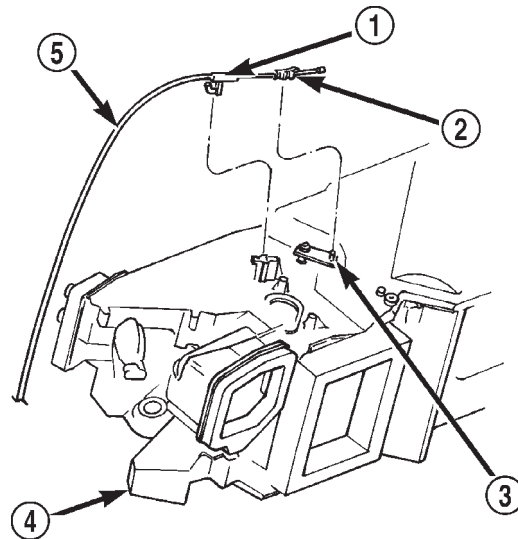

80a98371

Fig. 85 Temperature Control Cable Remove/Install

- 1 - FLAG RETAINER
- 2 - ADJUSTER CLIP
- 3 - BLEND-AIR DOOR LEVER
- 4 - HEATER-A/C HOUSING
- 5 - TEMPERATURE CONTROL CABLE

(5) Pull the temperature control cable core self-adjuster clip off of the pin on the end of the blend-air door lever.

(6) Remove the temperature control cable from the vehicle.

INSTALLATION

Before installing the temperature control cable, be certain that the self-adjuster clip is properly positioned (Fig. 86). This measurement must be made with the cable end bottomed against the flag retainer on the heater-A/C control end of the cable housing. The measurement is taken from the end of the flag retainer on the heater-A/C housing end of the cable to the center of the self-adjuster clip. If the self-adjuster clip is not properly positioned, slide the clip up or down the cable core as required to achieve the specified dimension.

(1) Connect the temperature control cable to the heater-A/C control. See Heater-A/C Control in the

REMOVAL AND INSTALLATION (Continued)

*MEASURED WITH CABLE END BOTTOMED
AGAINST HEATER-A/C CONTROL CABLE
HOUSING FLAG RETAINER

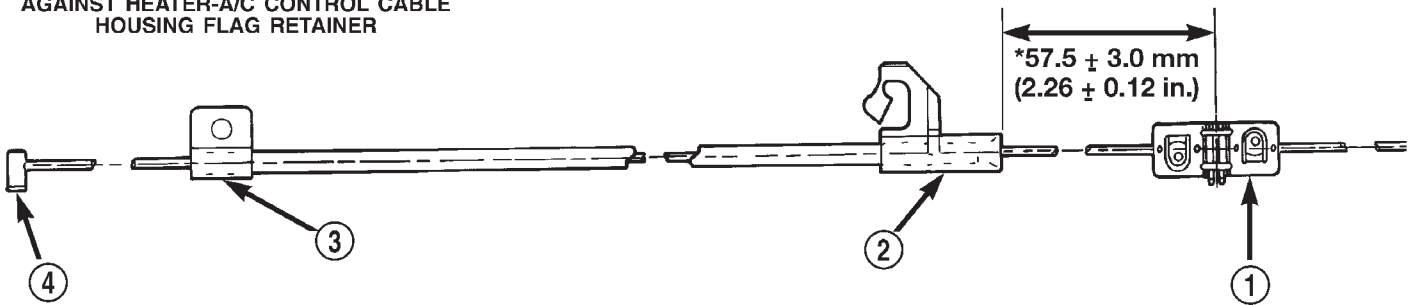

80b2b71b

Fig. 86 Temperature Control Cable Self-Adjuster Clip

- | | |
|--|--|
| 1 - SELF-ADJUSTER CLIP | 3 - HEATER-A/C CONTROL CABLE HOUSING FLAG RETAINER-
CONTROL END |
| 2 - HEATER-A/C CONTROL CABLE HOUSING FLAG RETAINER-
HOUSING END | 4 - CABLE END |

Removal and Installation section of this group for the procedures.

(2) Route the cable through the instrument panel. Position the cable end near the connection points on the HVAC unit assembly, making sure not to kink or distort the cable.

(3) Push the temperature control cable core self-adjuster clip onto the pin on the end of the blend-air door lever.

(4) Snap the temperature control cable housing flag retainer into the receiver on the top of the heater-A/C housing.

(5) Reinstall the instrument panel assembly. Refer to Instrument Panel Assembly in the Removal and Installation section of Group 8E - Instrument Panel Systems for the procedures.

(6) Connect the battery negative cable.

(7) Adjust the temperature control cable. See Temperature Control Cable in the Adjustments section of this group for the procedures.

UNDERBODY REFRIGERANT LINE

The underbody refrigerant lines are used only on models with the optional rear overhead A/C unit. Both the underbody suction line and the underbody liquid line are available for separate service replacement, and may be removed from the vehicle independently for service.

Any kinks or sharp bends in the refrigerant plumbing will reduce the capacity of the entire air conditioning system. Kinks and sharp bends reduce the flow of refrigerant in the system. High pressures are produced in the refrigerant system when the air conditioning compressor is operating. Extreme care must be exercised to make sure that each of the refrigerant system connections is pressure-tight and leak free.

WARNING: REVIEW THE WARNINGS AND CAUTIONS IN THE GENERAL INFORMATION SECTION NEAR THE FRONT OF THIS GROUP BEFORE PERFORMING THE FOLLOWING OPERATION.

REMOVAL

(1) Disconnect and isolate the battery negative cable.

(2) Recover the refrigerant from the refrigerant system. See Refrigerant Recovery in the Service Procedures section of this group.

(3) From the engine compartment, disconnect the underbody liquid line refrigerant line coupler at the liquid line extension and the underbody suction line refrigerant line coupler at the suction line jumper (Fig. 87). See Refrigerant Line Coupler in the Removal and Installation section of this group for the procedures. Install plugs in, or tape over all of the opened refrigerant line fittings.

(4) Raise and support the vehicle.

(5) From under the vehicle, disconnect the underbody liquid line refrigerant line coupler at the B-pillar liquid line and the underbody suction line refrigerant line coupler at the B-pillar suction line. See Refrigerant Line Coupler in the Removal and Installation section of this group for the procedures. Install plugs in, or tape over all of the opened refrigerant line fittings.

(6) Remove the screws that secure the three underbody refrigerant line clamps to the underbody.

(7) Remove the underbody refrigerant line unit from the vehicle.

INSTALLATION

(1) From under the vehicle, position the underbody refrigerant line unit to the underbody and secure the refrigerant line clamps with the mounting screws in

REMOVAL AND INSTALLATION (Continued)

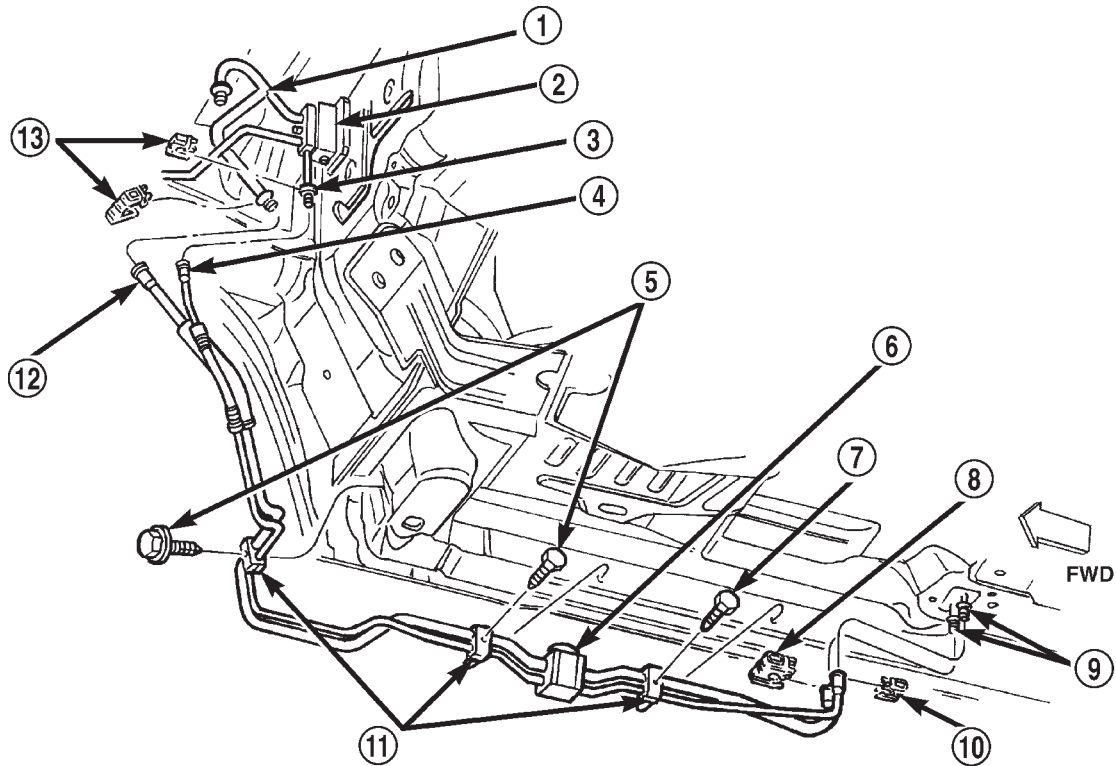

80b11cf0

Fig. 87 Underbody Refrigerant Line Remove/Install

- | | |
|---------------------------|--------------------------------|
| 1 - SUCTION LINE JUMPER | 8 - CLIP |
| 2 - FRONT EXPANSION VALVE | 9 - B-PILLAR REFRIGERANT LINES |
| 3 - LIQUID LINE EXTENSION | 10 - CLIP |
| 4 - UNDERBODY LIQUID LINE | 11 - CLAMPS |
| 5 - SCREWS | 12 - UNDERBODY SUCTION LINE |
| 6 - REAR EXPANSION VALVE | 13 - CLIPS |
| 7 - SCREW | |

three places. Tighten the mounting screws to 2.2 N-m (20 in. lbs.).

(2) Remove the tape or plugs from the refrigerant line fittings at the rear of the underbody liquid and suction lines and at the B-pillar liquid and suction lines. Connect the underbody refrigerant lines to the B-pillar refrigerant lines. See Refrigerant Line Coupler in the Removal and Installation section of this group for the procedures.

(3) Lower the vehicle.

(4) From the engine compartment, remove the tape or plugs from the refrigerant line fittings at the front of the underbody liquid and suction lines and at the liquid line extension and the suction line jumper. Connect the underbody refrigerant lines to the engine compartment refrigerant lines. See Refrigerant Line Coupler in the Removal and Installation section of this group for the procedures.

(5) Connect the battery negative cable.

(6) Evacuate the refrigerant system. See Refrigerant System Evacuate in the Service Procedures section of this group.

(7) Charge the refrigerant system. See Refrigerant System Charge in the Service Procedures section of this group.

VACUUM CHECK VALVE

(1) Unplug the vacuum supply line connector at the vacuum check valve (Fig. 88).

(2) Note the orientation of the check valve in the vacuum supply line for correct reinstallation.

(3) Unplug the vacuum check valve from the vacuum supply line fittings.

(4) Reverse the removal procedures to install.

VACUUM RESERVOIR

(1) Disconnect and isolate the battery negative cable.

(2) Remove the wiper arms from the wiper pivots. Refer to Wiper Arm in the Removal and Installation section of Group 8K - Wiper and Washer Systems for the procedures.

REMOVAL AND INSTALLATION (Continued)

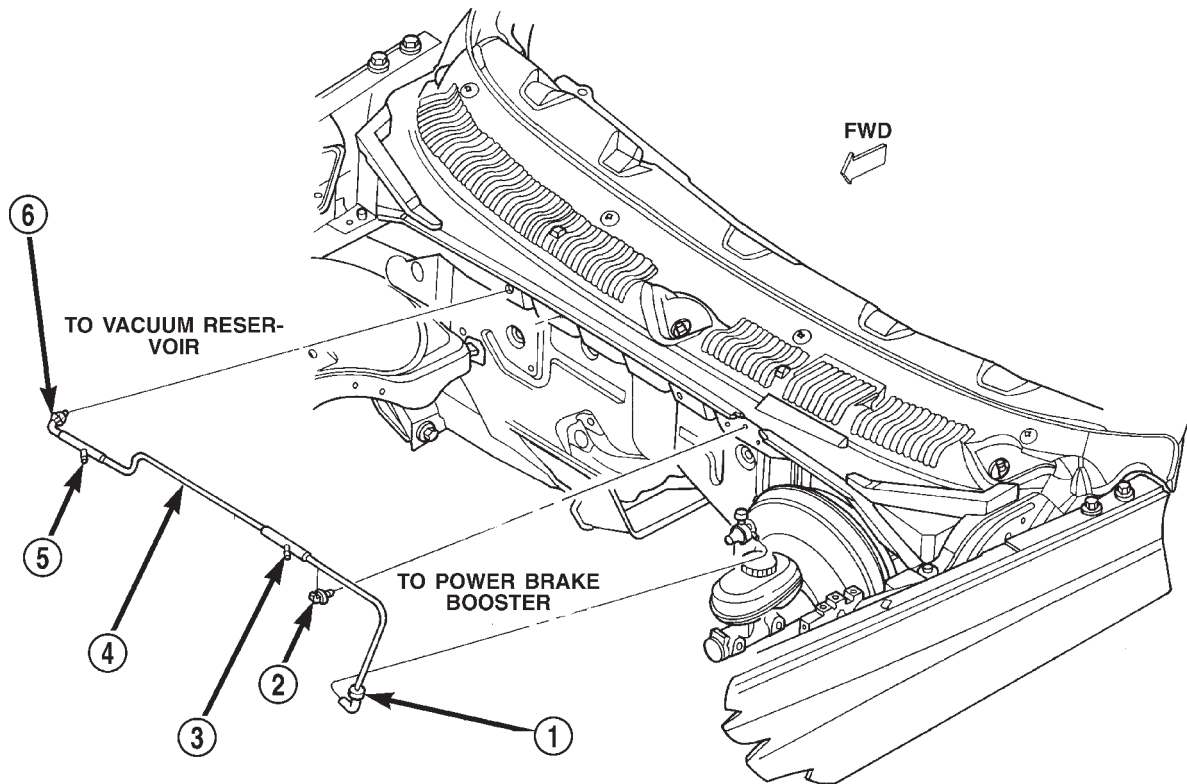

80a89406

Fig. 88 Vacuum Supply

- | | |
|---------------------------|----------------------------|
| 1 - VACUUM CHECK VALVE | 4 - VACUUM SUPPLY LINE |
| 2 - CLIP | 5 - TO SPEED CONTROL SERVO |
| 3 - TO HEATER-AC CONTROLS | 6 - GROMMET |

(3) Remove the weatherstrip along the front edge of the cowl plenum cover/grille panel and the cowl plenum panel (Fig. 89).

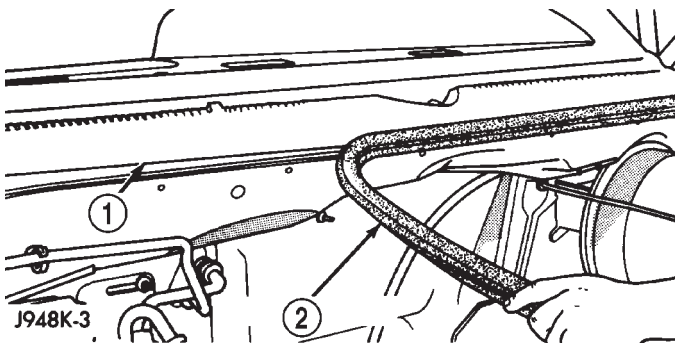

Fig. 89 Cowl Plenum Cover/Grille Panel Weatherstrip

- | |
|------------------|
| 1 - COWL GRILLE |
| 2 - WEATHERSTRIP |

(4) Remove the four plastic nuts that secure the cowl plenum cover/grille panel to the studs on the

cowl top panel near the base of the windshield (Fig. 90).

(5) Remove the one plastic rivet that secures the front corner on each side of the cowl plenum cover/grille panel to the cowl plenum panel.

(6) Remove the one plastic push-in retainer that secures the rear corner on each side of the cowl plenum cover/grille panel to the windshield reveal molding.

(7) Unsnap the slotted center hole on each side of the cowl plenum cover/grille panel from the adhesive-backed snap fastener. **(If equipped: This feature may not be on all models).**

(8) Lift the cowl plenum cover/grille panel from the cowl top far enough to access the windshield washer nozzle and vacuum plumbing near the right end of the cowl plenum.

(9) Disconnect the windshield washer supply hose at the in-line connector.

(10) Disconnect the vacuum supply hose from the vacuum reservoir, which is secured to the underside of the right end of the cowl plenum cover/grille panel (Fig. 91).

REMOVAL AND INSTALLATION (Continued)

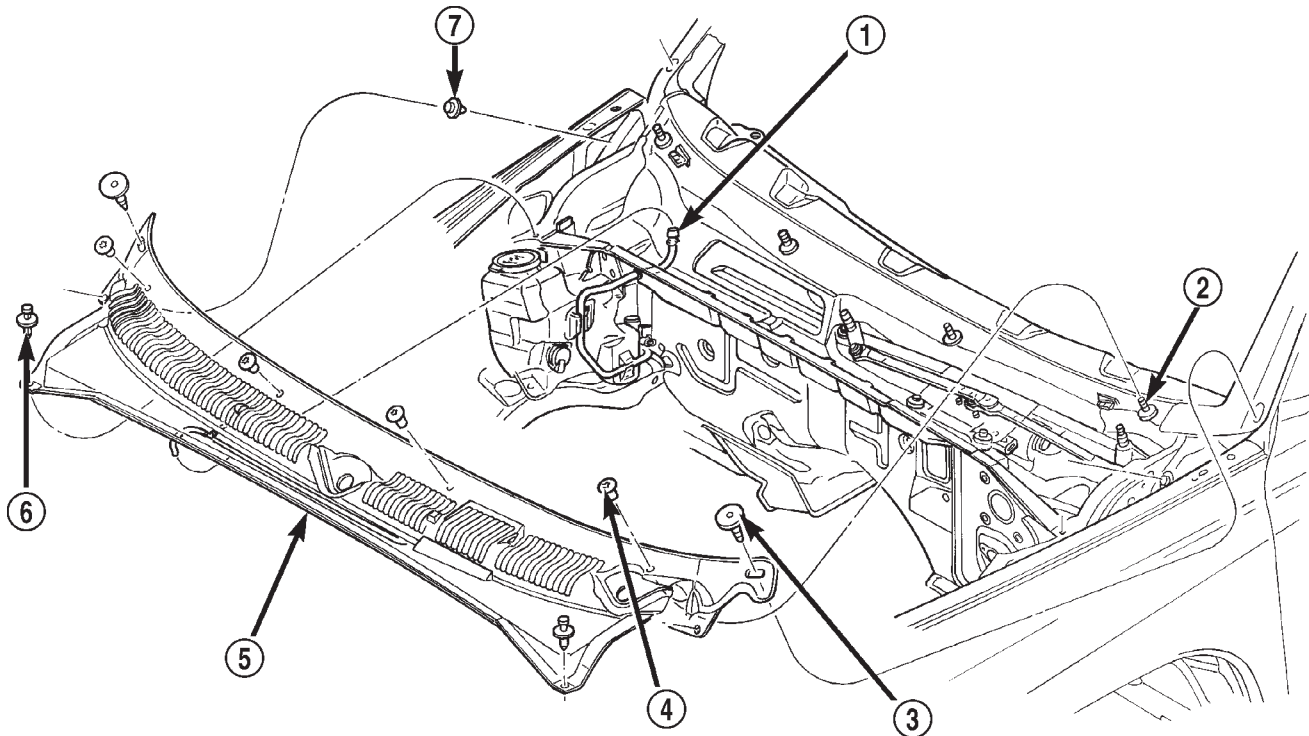

80ae8398

Fig. 90 Cowl Plenum Cover/Grille Panel Remove/Install

- | | |
|--|------------------------------------|
| 1 - IN-LINE WASHER SUPPLY HOSE CONNECTOR | 5 - COWL PLENUM COVER/GRILLE PANEL |
| 2 - STUD | 6 - PLASTIC RIVET |
| 3 - PUSH-IN PLASTIC RETAINER | 7 - ADHESIVE-BACKED SNAP FASTENER |
| 4 - PLASTIC NUT | |

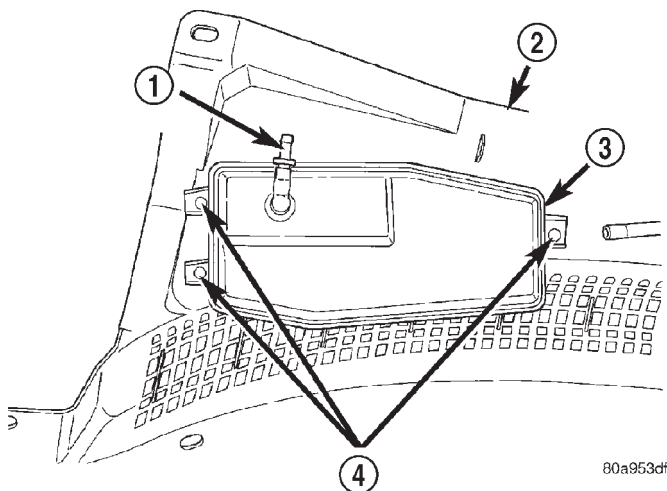

80a953df

Fig. 91 Vacuum Reservoir

- | |
|------------------------------------|
| 1 - VACUUM SUPPLY CONNECTOR |
| 2 - COWL PLENUM COVER/GRILLE PANEL |
| 3 - VACUUM RESERVOIR |
| 4 - SCREWS |

(11) Remove the cowl plenum cover/grille panel from the vehicle.

(12) Remove the three screws that secure the vacuum reservoir to the underside of the cowl plenum cover/grille panel.

(13) Remove the vacuum reservoir from the cowl plenum cover/grille panel.

(14) Reverse the removal procedures to install. Tighten the vacuum reservoir mounting screws to 2.2 N·m (20 in. lbs.).

ADJUSTMENTS

TEMPERATURE CONTROL CABLE

Any time the heater-A/C control or the temperature control cable are removed and/or replaced, the following procedure must be performed.

(1) The temperature control cable housing and core must be installed at both the heater-A/C control and the heater-A/C housing ends, and the heater-A/C control must be installed in the instrument panel. See Heater-A/C Control and Temperature Control Cable

ADJUSTMENTS (Continued)

in the Removal and Installation section of this group for the procedures.

(2) Rotate the temperature control knob on the heater-A/C control so that the knob pointer is in the 12 o'clock position.

(3) Pull the temperature control knob straight out from the heater-A/C control base until the perimeter of the knob (not the knob pointer) protrudes about 6 millimeters (0.25 inch) from the face of the control base.

(4) Rotate the temperature control knob to the 1 o'clock position. Push in on the knob slightly and continue rotating the knob to its full clockwise stop. The knob pointer should be aimed at a position about 8 millimeters (0.315 inch) beyond the end of the graduated red strobe temperature control graphic on the face of the heater-A/C control base. If the knob is not pointed to the correct position, go back to Step 2 and repeat the adjustment procedure.

(5) Rotate the temperature control knob counterclockwise until the knob pointer is in the 12 o'clock position again.

(6) Push the temperature control knob straight in towards the heater-A/C control base until the perimeter of the knob (not the knob pointer) is flush with the face of the heater-A/C control base.

(7) Rotate the knob to its full clockwise stop again. The knob pointer should be aimed at the end of the graduated red strobe temperature control graphic on the face of the heater-A/C control base. If OK, go to Step 8. If not OK, go back to Step 2.

(8) Rotate the knob to its full counterclockwise stop and release the knob. If the knob springs back from the counterclockwise stop, the self-adjuster clip that secures the temperature control cable to the blend-air door lever is improperly installed. See Temperature Control Cable in the Removal and Installation section of this group for the procedures. If the knob does not spring back, the temperature control cable adjustment is complete.

SPECIFICATIONS

A/C APPLICATION TABLE

Item	Description	Notes
VEHICLE	Durango	
SYSTEM	R134a w/expansion valve	
Optional - Rear A/C	Evaporator in roof, Rear blower switch in headliner	
COMPRESSOR	Sanden SD7H15	SP-20 PAG oil
Freeze-up Control	Electronic Clutch Cycling Switch (ECCS)	mounted on expansion valve
Low psi Control	opens < 7-13 psi - resets > 15-28 psi	mounted on suction line jumper
High psi Control	opens > 450-490 psi - resets < 270-330 psi	mounted on discharge line
CONTROL HEAD	manual type	
Mode Door	vacuum	
Blend Air Door	cable	
Fresh/Recirc door	vacuum	
Blower Motor	hardwired to control head	resistor block
COOLING FANS	viscous clutch/electric fan cooling module	
CLUTCH		
Control	relay	PCM
Draw	2.0 - 3.9 amps @ 12 V	± 0.5V @ 70° F
Gap	0.016" - 0.031"	
DRB III®		
Reads	TPS, RPM, A/C switch	
Actuators	clutch	

