

# FUEL SYSTEM

## TABLE OF CONTENTS

	page		page
FUEL DELIVERY SYSTEM.....	1	FUEL INJECTION SYSTEM .....	27

# FUEL DELIVERY SYSTEM

## TABLE OF CONTENTS

	page		page
<b>DESCRIPTION AND OPERATION</b>		<b>QUICK-CONNECT FITTINGS .....</b>	<b>11</b>
PCM VIN REPROGRAMMING .....	1	<b>REMOVAL AND INSTALLATION</b>	
FUEL DELIVERY SYSTEM.....	2	FUEL FILTER/FUEL PRESSURE REGULATOR...	14
FUEL PUMP MODULE .....	2	FUEL PUMP MODULE .....	15
FUEL PUMP.....	2	FUEL PUMP INLET FILTER .....	16
FUEL GAUGE SENDING UNIT.....	3	FUEL GAUGE SENDING UNIT.....	16
FUEL FILTER/FUEL PRESSURE REGULATOR...	3	FUEL INJECTOR RAIL—3.9/5.2/5.9L ENGINES ..	17
FUEL TANK .....	4	FUEL INJECTOR RAIL—4.7L V-8 ENGINE.....	19
FUEL INJECTORS .....	4	FUEL INJECTOR(S).....	20
FUEL RAIL—3.9/5.2/5.9L ENGINES .....	5	FUEL TANK .....	20
FUEL INJECTOR RAIL—4.7L ENGINE .....	5	FUEL TANK FILLER TUBE CAP .....	22
FUEL TANK FILLER TUBE CAP .....	5	ACCELERATOR PEDAL.....	22
FUEL TUBES/LINES/HOSES AND CLAMPS.....	6	THROTTLE CABLE .....	23
QUICK-CONNECT FITTINGS .....	6	THROTTLE CABLE—4.7L V-8 ENGINE.....	24
<b>DIAGNOSIS AND TESTING</b>		<b>SPECIFICATIONS</b>	
FUEL PUMP PRESSURE TEST .....	6	FUEL TANK CAPACITY .....	24
FUEL PUMP CAPACITY TEST .....	7	FUEL SYSTEM PRESSURE .....	24
FUEL PRESSURE LEAK DOWN TEST.....	7	FUEL REQUIREMENTS .....	24
FUEL PUMP AMPERAGE TEST .....	8	TORQUE CHART.....	26
FUEL GAUGE SENDING UNIT.....	9		
FUEL INJECTOR TEST .....	10		
<b>SERVICE PROCEDURES</b>			
FUEL SYSTEM PRESSURE RELEASE			
PROCEDURE .....	10		

## DESCRIPTION AND OPERATION

### PCM VIN REPROGRAMMING

#### OPERATION

**USE THE DRB SCAN TOOL TO REPROGRAM THE NEW POWERTRAIN CONTROL MODULE**

**(PCM) WITH THE VEHICLES ORIGINAL IDENTIFICATION NUMBER (VIN) AND THE VEHICLES ORIGINAL MILEAGE. IF THIS STEP IS NOT DONE, A DIAGNOSTIC TROUBLE CODE (DTC) MAY BE SET.**

## DESCRIPTION AND OPERATION (Continued)

## FUEL DELIVERY SYSTEM

## DESCRIPTION

The fuel delivery system consists of:

- the fuel pump module containing the electric fuel pump, fuel filter/fuel pressure regulator, fuel gauge sending unit (fuel level sensor) and a separate fuel filter located at bottom of pump module

- fuel tubes/lines/hoses
- quick-connect fittings
- fuel injector rail
- fuel injectors
- fuel tank
- fuel tank filler/vent tube assembly
- fuel tank filler tube cap
- accelerator pedal
- throttle cable

## OPERATION

Fuel is returned through the fuel pump module and back into the fuel tank through the fuel filter/fuel pressure regulator. A separate fuel return line from the engine to the tank is not used.

The fuel tank assembly consists of: the fuel tank, fuel pump module assembly, fuel pump module metal lockring and gasket, and rollover valve (refer to Group 25, Emission Control System for rollover valve information).

A fuel filler/vent tube assembly using a pressure/vacuum, 1/4 turn fuel filler cap is used. The fuel filler tube contains a flap door located below the fuel fill cap.

Also to be considered part of the fuel system is the evaporation control system. This is designed to reduce the emission of fuel vapors into the atmosphere. The description and function of the Evaporative Control System is found in Group 25, Emission Control Systems.

Both fuel filters (at bottom of fuel pump module and within fuel pressure regulator) are designed for extended service. They do not require normal scheduled maintenance. Filters should only be replaced if a diagnostic procedure indicates to do so.

## FUEL PUMP MODULE

## DESCRIPTION

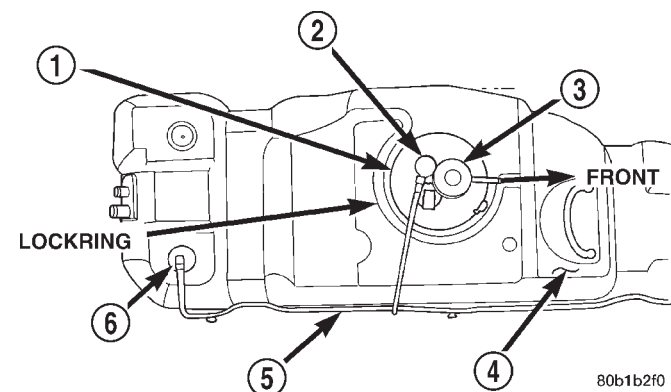
The fuel pump module on all models/all engines is installed in the top of the fuel tank (Fig. 1). The fuel pump module contains the following components (Fig. 2):

- A combination fuel filter/fuel pressure regulator
- Electric fuel pump
- Fuel pump reservoir
- A separate in-tank fuel filter (at bottom of module)

- Fuel gauge sending unit (fuel level sensor)
- Fuel supply line connection at filter/regulator
- A metal lockring to retain pump module to fuel tank

- A gasket between tank flange and module

The fuel gauge sending unit (fuel level sensor), and pick-up filter (at bottom of module) may be serviced separately. If the electrical fuel pump requires service, the entire fuel pump module must be replaced.



**Fig. 1 Fuel Pump Module/Fuel Tank (Top View)**

- 1 - FUEL PUMP MODULE
- 2 - FRONT ROLLOVER VALVE
- 3 - FUEL FILTER/FUEL PRESSURE REGULATOR
- 4 - FUEL TANK
- 5 - EVAP LINE
- 6 - REAR ROLLOVER VALVE

## OPERATION

Refer to Fuel Pump, Fuel Filter/Fuel Pressure Regulator and Fuel Gauge Sending Unit.

## FUEL PUMP

## DESCRIPTION

The fuel pump is located inside of the fuel pump module. A 12 volt, permanent magnet, electric motor powers the fuel pump.

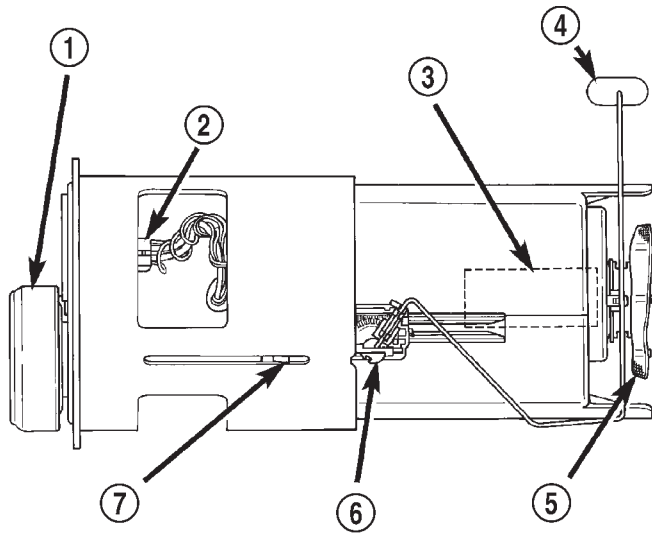
## OPERATION

Voltage to operate the electric pump is supplied through the fuel pump relay.

Fuel is drawn in through a filter at the bottom of the module and pushed through the electric motor gearset to the pump outlet.

**Check Valve Operation:** The pump outlet contains a one-way check valve to prevent fuel flow back into the tank and to maintain fuel supply line pressure (engine warm) when pump is not operational. It is also used to keep the fuel supply line full of gasoline when pump is not operational. After the vehicle has cooled down, fuel pressure may drop to 0 psi (cold fluid contracts), but liquid gasoline will remain in fuel supply line between the check valve and fuel

DESCRIPTION AND OPERATION (Continued)



80b0d725

**Fig. 2 Fuel Pump Module Components (Typical Pump Module Shown)**

- 1 - FUEL FILTER/PRESSURE REGULATOR
- 2 - ELECTRICAL CONNECTOR
- 3 - ELECTRIC FUEL PUMP
- 4 - FUEL GAUGE FLOAT
- 5 - FUEL PUMP INLET FILTER
- 6 - FUEL GAUGE SENDING UNIT
- 7 - MODULE LOCK TABS (3)

injectors. **Fuel pressure that has dropped to 0 psi on a cooled down vehicle (engine off) is a normal condition.** Refer to the Fuel Pressure Leak Down Test for more information.

**FUEL GAUGE SENDING UNIT**

**DESCRIPTION**

The fuel gauge sending unit (fuel level sensor) is attached to the side of the fuel pump module. The sending unit consists of a float, an arm, and a variable resistor track (card).

**OPERATION**

The fuel pump module has 4 different circuits (wires). Two of these circuits are used for the fuel gauge sending unit for fuel gauge operation, and for certain OBD II emission requirements. The other 2 wires are used for electric fuel pump operation.

**For Fuel Gauge Operation:** A constant current source of about 32 mA is supplied to the resistor track on the fuel gauge sending unit. This is fed directly from the Powertrain Control Module (PCM). The resistor track is used to vary the voltage depending on fuel tank float level. As fuel level increases, the float and arm move up, which decreases voltage. As fuel level decreases, the float and arm move down, which increases voltage. The varied voltage

signal is returned back to the PCM through the sensor return circuit. Output voltages will vary from about .6 volts at FULL, to about 8.6 volts at EMPTY (Jeep models), or, about 7.0 volts at EMPTY (Dodge Truck models). **NOTE: For diagnostic purposes, this voltage can only be verified with the fuel gauge sending unit circuit closed (i.e. having all of the sending units electrical connectors connected).**

Both of the electrical circuits between the fuel gauge sending unit and the PCM are hard-wired (not multi-plexed). After the voltage signal is sent from the resistor track, and back to the PCM, the PCM will interpret the resistance (voltage) data and send a message across the multi-plex bus circuits to the instrument panel cluster. Here it is translated into the appropriate fuel gauge level reading. Refer to Instrument Panel for additional information.

**For OBD II Emission Monitor Requirements:** The PCM will monitor the voltage output sent from the resistor track on the sending unit to indicate fuel level. The purpose of this feature is to prevent the OBD II system from recording/setting false misfire and fuel system monitor diagnostic trouble codes. The feature is activated if the fuel level in the tank is less than approximately 15 percent of its rated capacity. If equipped with a Leak Detection Pump (EVAP system monitor), this feature will also be activated if the fuel level in the tank is more than approximately 85 percent of its rated capacity.

**FUEL FILTER/FUEL PRESSURE REGULATOR**

**DESCRIPTION**

A combination fuel filter and fuel pressure regulator (Fig. 3) is used on all engines. It is located on the top of the fuel pump module. A separate frame mounted fuel filter is not used with any engine.

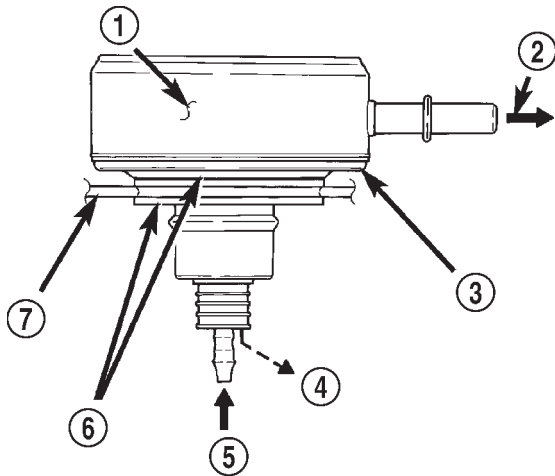
Both fuel filters (at bottom of fuel pump module and within fuel pressure regulator) are designed for extended service. They do not require normal scheduled maintenance. Filters should only be replaced if a diagnostic procedure indicates to do so.

**OPERATION**

**Fuel Pressure Regulator Operation:** The pressure regulator is a mechanical device that is not controlled by engine vacuum or the powertrain control module (PCM).

The regulator is calibrated to maintain fuel system operating pressure of approximately 339 kPa ± 34 kPa (49.2 psi ± 5 psi) at the fuel injectors. It contains a diaphragm, calibrated springs and a fuel return valve. The internal fuel filter (Fig. 3) is also part of the assembly.

## DESCRIPTION AND OPERATION (Continued)



80a92a65

**Fig. 3 Side View—Filter/Regulator**

- 1 - INTERNAL FUEL FILTER
- 2 - FUEL FLOW TO FUEL INJECTORS
- 3 - FUEL FILTER/FUEL PRESSURE REGULATOR
- 4 - EXCESS FUEL BACK TO TANK
- 5 - FUEL INLET
- 6 - RUBBER GROMMET
- 7 - TOP OF PUMP MODULE

Fuel is supplied to the filter/regulator by the electric fuel pump through an opening tube at the bottom of filter/regulator (Fig. 3).

The regulator acts as a check valve to maintain some fuel pressure when the engine is not operating. This will help to start the engine. A second check valve is located at the outlet end of the electric fuel pump. **Refer to Fuel Pump—Description and Operation for more information. Also refer to the Fuel Pressure Leak Down Test and the Fuel Pump Pressure Tests.**

If fuel pressure at the pressure regulator exceeds approximately 49.2 psi, an internal diaphragm opens and excess fuel pressure is routed back into the tank through the bottom of pressure regulator.

Both fuel filters (at bottom of fuel pump module and within fuel pressure regulator) are designed for extended service. They do not require normal scheduled maintenance. Filters should only be replaced if a diagnostic procedure indicates to do so.

## FUEL TANK

### DESCRIPTION

The fuel tank is constructed of a plastic material. Its main functions are for fuel storage and for placement of the fuel pump module.

### OPERATION

All models pass a full 360 degree rollover test without fuel leakage. To accomplish this, fuel and

vapor flow controls are required for all fuel tank connections.

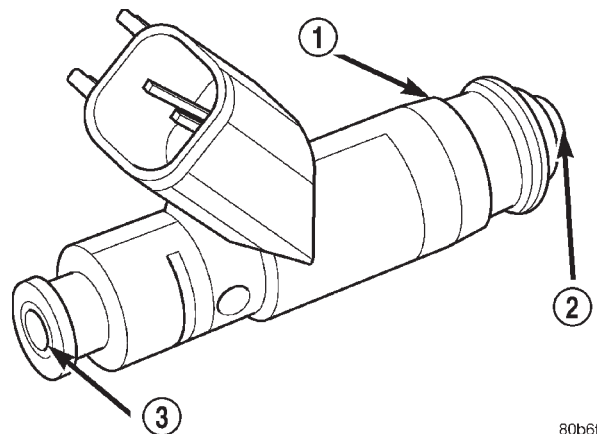
A rollover valve(s) is mounted into the top of the fuel tank (or pump module). Refer to Emission Control System for rollover valve information.

An evaporation control system is connected to the rollover valve(s) to reduce emissions of fuel vapors into the atmosphere. When fuel evaporates from the fuel tank, vapors pass through vent hoses or tubes to a charcoal canister where they are temporarily held. When the engine is running, the vapors are drawn into the intake manifold. Certain models are also equipped with a self-diagnosing system using a Leak Detection Pump (LDP). Refer to Emission Control System for additional information.

## FUEL INJECTORS

### DESCRIPTION

An individual fuel injector (Fig. 4) is used for each individual cylinder.



80b6f035

**Fig. 4 Fuel Injector—Typical**

- 1 - FUEL INJECTOR
- 2 - NOZZLE
- 3 - TOP (FUEL ENTRY)

### OPERATION

The top (fuel entry) end of the injector (Fig. 4) is attached into an opening on the fuel rail.

The fuel injectors are electrical solenoids. The injector contains a pintle that closes off an orifice at the nozzle end. When electric current is supplied to the injector, the armature and needle move a short distance against a spring, allowing fuel to flow out the orifice. Because the fuel is under high pressure, a fine spray is developed in the shape of a pencil stream. The spraying action atomizes the fuel, adding it to the air entering the combustion chamber.

The nozzle (outlet) ends of the injectors are positioned into openings in the intake manifold just above the intake valve ports of the cylinder head.

DESCRIPTION AND OPERATION (Continued)

The engine wiring harness connector for each fuel injector is equipped with an attached numerical tag (INJ 1, INJ 2 etc.). This is used to identify each fuel injector.

The injectors are energized individually in a sequential order by the powertrain control module (PCM). The PCM will adjust injector pulse width by switching the ground path to each individual injector on and off. Injector pulse width is the period of time that the injector is energized. The PCM will adjust injector pulse width based on various inputs it receives.

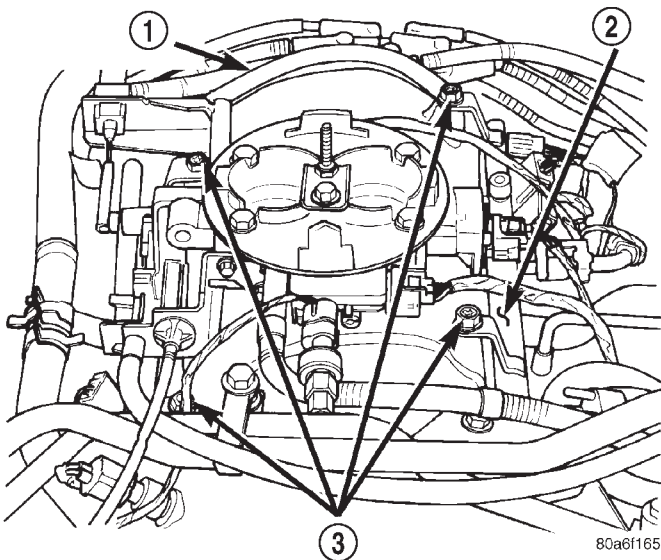
Battery voltage is supplied to the injectors through the ASD relay.

The PCM determines injector pulse width based on various inputs.

**FUEL RAIL—3.9/5.2/5.9L ENGINES**

**DESCRIPTION**

The fuel injector rail is used to attach the fuel injectors to the engine. It is mounted to the engine (Fig. 5).



**Fig. 5 Fuel Rail—3.9/5.2/5.9L Engine—Typical**

- 1 - FUEL RAIL CONNECTING HOSE
- 2 - FUEL RAIL
- 3 - MOUNTING BOLTS (4)

**OPERATION**

High pressure from the fuel pump is routed to the fuel rail. The fuel rail then supplies the necessary fuel to each individual fuel injector.

A fuel pressure test port is located on the fuel rail. A quick-connect fitting with a safety latch clip is used to attach the fuel line to the fuel rail.

The fuel rail is not repairable.

**CAUTION:** The left and right sections of the fuel rail are connected with a flexible connecting hose. Do not attempt to separate the rail halves at this connecting hose. Due to the design of this connecting hose, it does not use any clamps. Never attempt to install a clamping device of any kind to the hose. When removing the fuel rail assembly for any reason, be careful not to bend or kink the connecting hose.

**FUEL INJECTOR RAIL—4.7L ENGINE**

**DESCRIPTION**

The fuel injector rail is used to mount the fuel injectors to the engine. It is mounted to the intake manifold (Fig. 6).

**OPERATION**

High pressure fuel from the fuel pump is routed to the fuel rail. The fuel rail then supplies the necessary fuel to each individual fuel injector.

A fuel pressure test port is located on the fuel rail (Fig. 6). A quick-connect fitting with a safety latch is used to attach the fuel line to the fuel rail.

The fuel rail is not repairable.

**CAUTION:** 4.7L Engine Only: The left and right sections of the fuel rail are joined with a connector tube (Fig. 6). Do not attempt to separate the rail halves at this tube. Due to the design of this connecting tube, it does not use any clamps. Never attempt to install a clamping device of any kind to the tube. When removing the fuel rail assembly for any reason, be careful not to bend or kink the connector tube.

**FUEL TANK FILLER TUBE CAP**

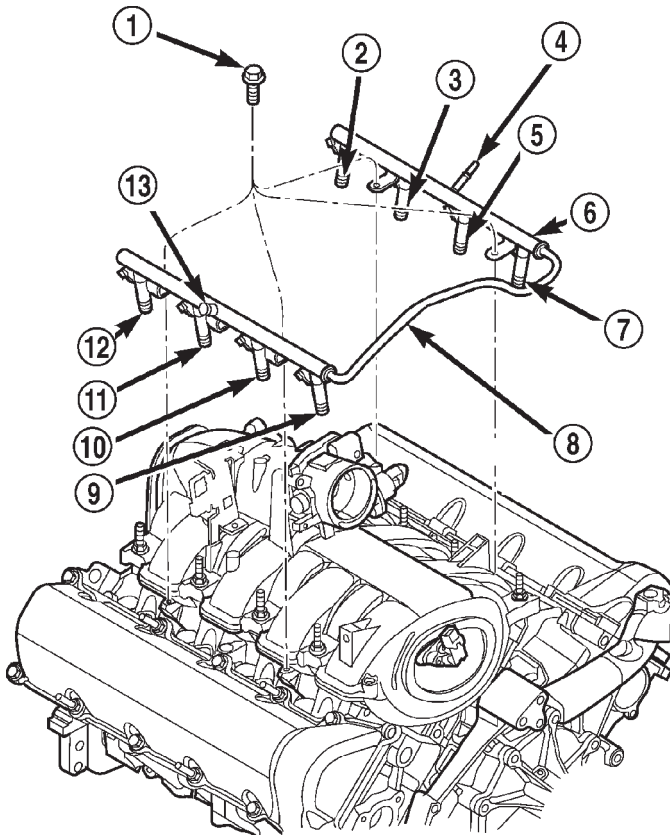
**DESCRIPTION**

The plastic fuel tank filler tube cap is threaded onto the end of the fuel fill tube. Certain models are equipped with a 1/4 turn cap.

**OPERATION**

The loss of any fuel or vapor out of fuel filler tube is prevented by the use of a pressure-vacuum fuel fill cap. Relief valves inside the cap will release fuel tank pressure at predetermined pressures. Fuel tank vacuum will also be released at predetermined values. This cap must be replaced by a similar unit if replacement is necessary. This is in order for the system to remain effective.

## DESCRIPTION AND OPERATION (Continued)



80b898e4

**Fig. 6 Fuel Injector Rail—4.7L V-8 Engine**

- 1 - MOUNTING BOLTS (4)
- 2 - INJ.#7
- 3 - INJ.#5
- 4 - QUICK-CONNECT FITTING
- 5 - INJ.#3
- 6 - FUEL INJECTOR RAIL
- 7 - INJ.#1
- 8 - CONNECTOR TUBE
- 9 - INJ.#2
- 10 - INJ.#4
- 11 - INJ.#6
- 12 - INJ.#8
- 13 - PRESSURE TEST PORT CAP

**CAUTION:** Remove fill cap before servicing any fuel system component to relieve tank pressure. If equipped with a California emissions package and a Leak Detection Pump (LDP), the cap must be tightened securely. If cap is left loose, a Diagnostic Trouble Code (DTC) may be set.

## FUEL TUBES/LINES/HOSES AND CLAMPS

### DESCRIPTION

Also refer to Quick-Connect Fittings.

**WARNING:** THE FUEL SYSTEM IS UNDER A CONSTANT PRESSURE (EVEN WITH THE ENGINE OFF).

**BEFORE SERVICING ANY FUEL SYSTEM HOSES, FITTINGS OR LINES, THE FUEL SYSTEM PRESSURE MUST BE RELEASED. REFER TO THE FUEL SYSTEM PRESSURE RELEASE PROCEDURE IN THIS GROUP.**

The lines/tubes/hoses used on fuel injected vehicles are of a special construction. This is due to the higher fuel pressures and the possibility of contaminated fuel in this system. If it is necessary to replace these lines/tubes/hoses, only those marked EFM/EFI may be used.

**If equipped:** The hose clamps used to secure rubber hoses on fuel injected vehicles are of a special rolled edge construction. This construction is used to prevent the edge of the clamp from cutting into the hose. Only these rolled edge type clamps may be used in this system. All other types of clamps may cut into the hoses and cause high-pressure fuel leaks.

Use new original equipment type hose clamps.

## QUICK-CONNECT FITTINGS

### DESCRIPTION

Different types of quick-connect fittings are used to attach various fuel system components, lines and tubes. These are: a single-tab type, a two-tab type or a plastic retainer ring type. Some are equipped with safety latch clips. Some may require the use of a special tool for disconnection and removal. Refer to Quick-Connect Fittings Removal/Installation for more information.

**CAUTION:** The interior components (o-rings, clips) of quick-connect fittings are not serviced separately, but new plastic spacers are available for some types. If service parts are not available, do not attempt to repair the damaged fitting or fuel line (tube). If repair is necessary, replace the complete fuel line (tube) assembly.

## DIAGNOSIS AND TESTING

### FUEL PUMP PRESSURE TEST

Use this test in conjunction with the Fuel Pump Capacity Test, Fuel Pressure Leak Down Test and Fuel Pump Amperage Test found elsewhere in this group.

**Check Valve Operation:** The electric fuel pump outlet contains a one-way check valve to prevent fuel flow back into the tank and to maintain fuel supply line pressure (engine warm) when pump is not operational. It is also used to keep the fuel supply line full of gasoline when pump is not operational. After the vehicle has cooled down, fuel pressure may drop

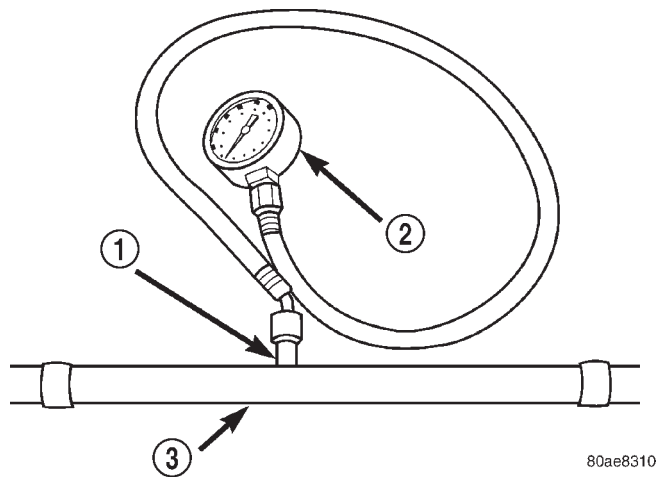
## DIAGNOSIS AND TESTING (Continued)

to 0 psi (cold fluid contracts), but liquid gasoline will remain in fuel supply line between the check valve and fuel injectors. **Fuel pressure that has dropped to 0 psi on a cooled down vehicle (engine off) is a normal condition.** When the electric fuel pump is activated, fuel pressure should **immediately** (1–2 seconds) rise to specification.

All fuel systems are equipped with a fuel tank module mounted, combination fuel filter/fuel pressure regulator. The fuel pressure regulator is not controlled by engine vacuum.

**WARNING: THE FUEL SYSTEM IS UNDER CONSTANT FUEL PRESSURE EVEN WITH THE ENGINE OFF. BEFORE DISCONNECTING FUEL LINE AT FUEL RAIL, THIS PRESSURE MUST BE RELEASED. REFER TO THE FUEL SYSTEM PRESSURE RELEASE PROCEDURE.**

(1) Remove protective cap at fuel rail test port. Connect the 0–414 kPa (0–60 psi) fuel pressure gauge (from gauge set 5069) to test port pressure fitting on fuel rail (Fig. 7). **The DRB III Scan Tool along with the PEP module, the 500 psi pressure transducer, and the transducer-to-test port adapter may also be used in place of the fuel pressure gauge.**



**Fig. 7 Fuel Pressure Test Gauge (Typical Gauge Installation at Test Port)**

- 1 - SERVICE (TEST) PORT  
2 - FUEL PRESSURE TEST GAUGE  
3 - FUEL RAIL

(2) Start and warm engine and note pressure gauge reading. Fuel pressure should be 339 kPa  $\pm$  34 kPa (49.2 psi  $\pm$  5 psi) at idle.

(3) If engine runs, but pressure is below 44.2 psi, check for a kinked fuel supply line somewhere between fuel rail and fuel pump module. If line is not kinked, but specifications for either the Fuel Pump

Capacity, Fuel Pump Amperage or Fuel Pressure Leak Down Tests were not met, replace fuel pump module assembly. Refer to Fuel Pump Module Removal/Installation.

(4) If operating pressure is above 54.2 psi, electric fuel pump is OK, but fuel pressure regulator is defective. Replace fuel filter/fuel pressure regulator. Refer to Fuel Filter/Fuel Pressure Regulator Removal/Installation for more information.

(5) Install protective cap to fuel rail test port.

### FUEL PUMP CAPACITY TEST

**Before performing this test, verify fuel pump pressure. Refer to Fuel Pump Pressure Test. Use this test in conjunction with the Fuel Pressure Leak Down Test.**

(1) Release fuel system pressure. Refer to Fuel Pressure Release Procedure.

(2) Disconnect fuel supply line at fuel rail. Refer to Quick-Connect Fittings. Some engines may require air cleaner housing removal before line disconnection.

(3) Obtain correct Fuel Line Pressure Test Adapter Tool Hose. Tool number 6539 is used for 5/16" fuel lines and tool number 6631 is used for 3/8" fuel lines.

(4) Connect correct Fuel Line Pressure Test Adapter Tool Hose into disconnected fuel supply line. Insert other end of Adaptor Tool Hose into a graduated container.

(5) Remove fuel fill cap.

(6) To activate fuel pump and pressurize system, obtain DRB scan tool and actuate ASD Fuel System Test.

(7) A good fuel pump will deliver at least 1/4 liter of fuel in 7 seconds. Do not operate fuel pump for longer than 7 seconds with fuel line disconnected as fuel pump module reservoir may run empty.

(a) If capacity is lower than specification, but fuel pump can be heard operating through fuel fill cap opening, check for a kinked/damaged fuel supply line somewhere between fuel rail and fuel pump module.

(b) If line is not kinked/damaged, and fuel pressure is OK, but capacity is low, replace fuel filter/fuel pressure regulator. The filter/regulator may be serviced separately on certain applications. Refer to Fuel Filter/Fuel Pressure Regulator Removal/Installation for additional information.

(c) If both fuel pressure and capacity are low, replace fuel pump module assembly. Refer to Fuel Pump Module Removal/Installation.

### FUEL PRESSURE LEAK DOWN TEST

Use this test in conjunction with the Fuel Pump Pressure Test and Fuel Pump Capacity Test.

**Check Valve Operation:** The electric fuel pump outlet contains a one-way check valve to prevent fuel

## DIAGNOSIS AND TESTING (Continued)

flow back into the tank and to maintain fuel supply line pressure (engine warm) when pump is not operational. It is also used to keep the fuel supply line full of gasoline when pump is not operational. After the vehicle has cooled down, fuel pressure may drop to 0 psi (cold fluid contracts), but liquid gasoline will remain in fuel supply line between the check valve and fuel injectors. **Fuel pressure that has dropped to 0 psi on a cooled down vehicle (engine off) is a normal condition.** When the electric fuel pump is activated, fuel pressure should **immediately** (1–2 seconds) rise to specification.

Abnormally long periods of cranking to restart a **hot** engine that has been shut down for a short period of time may be caused by:

- Fuel pressure bleeding past a fuel injector(s).
- Fuel pressure bleeding past the check valve in the fuel pump module.

(1) Disconnect the fuel inlet line at fuel rail. Refer to Fuel Tubes/Lines/Hoses and Clamps in this section of the group for procedures. On some engines, air cleaner housing removal may be necessary before fuel line disconnection.

(2) Obtain correct Fuel Line Pressure Test Adapter Tool Hose. Tool number 6539 is used for 5/16" fuel lines and tool number 6631 is used for 3/8" fuel lines.

(3) Connect correct Fuel Line Pressure Test Adapter Tool Hose between disconnected fuel line and fuel rail (Fig. 8).

(4) Connect the 0-414 kPa (0-60 psi) fuel pressure test gauge (from Gauge Set 5069) to the test port on the appropriate Adaptor Tool. **The DRB III Scan Tool along with the PEP module, the 500 psi pressure transducer, and the transducer-to-test port adapter may also be used in place of the fuel pressure gauge.**

**The fittings on both tools must be in good condition and free from any small leaks before performing the proceeding test.**

(5) Start engine and bring to normal operating temperature.

(6) Observe test gauge. Normal operating pressure should be 339 kPa  $\pm$  34 kPa (49.2 psi  $\pm$  5 psi).

(7) Shut engine off.

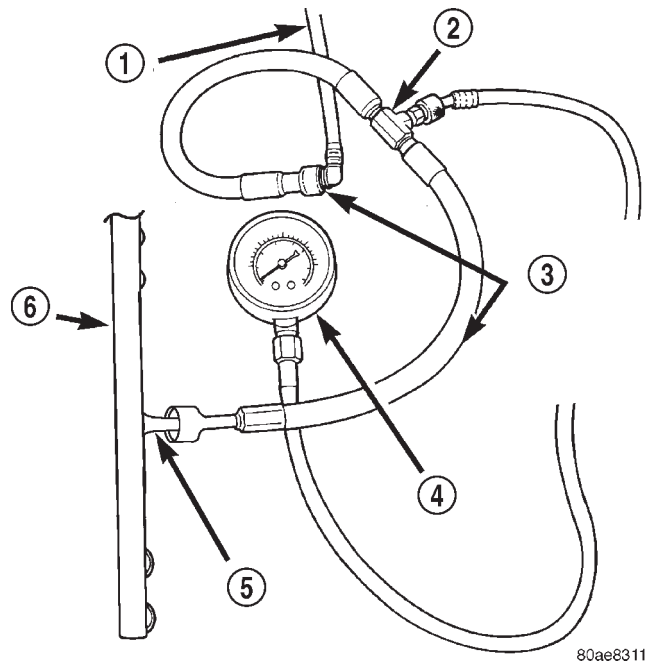
(8) Pressure should not fall below **30 psi for five minutes.**

(9) If pressure falls below 30 psi, it must be determined if a fuel injector, the check valve within the fuel pump module, or a fuel tube/line is leaking.

(10) Again, start engine and bring to normal operating temperature.

(11) Shut engine off.

(12) **Testing for fuel injector or fuel rail leakage:** Clamp off the rubber hose portion of Adaptor Tool between the fuel rail and the test port "T" on



**Fig. 8 Connecting Adapter Tool—Typical**

- 1 - VEHICLE FUEL LINE
- 2 - TEST PORT "T"
- 3 - SPECIAL TOOL 6923, 6631, 6541 OR 6539
- 4 - FUEL PRESSURE TEST GAUGE
- 5 - FUEL LINE CONNECTION AT RAIL
- 6 - FUEL RAIL

Adapter Tool. If pressure now holds at or above 30 psi, a fuel injector or the fuel rail is leaking.

(13) **Testing for fuel pump check valve, filter/regulator check valve or fuel tube/line leakage:** Clamp off the rubber hose portion of Adaptor Tool between the vehicle fuel line and test port "T" on Adaptor Tool. If pressure now holds at or above 30 psi, a leak may be found at a fuel tube/line. If no leaks are found at fuel tubes or lines, one of the check valves in either the electric fuel pump or filter/regulator may be leaking.

Note: A quick loss of pressure usually indicates a defective check valve in the filter/regulator. A slow loss of pressure usually indicates a defective check valve in the electric fuel pump.

The electric fuel pump is not serviced separately. Replace the fuel pump module assembly. The filter/regulator may be replaced separately on certain applications. Refer to Fuel Filter/Fuel Pressure Regulator Removal/Installation for additional information.

## FUEL PUMP AMPERAGE TEST

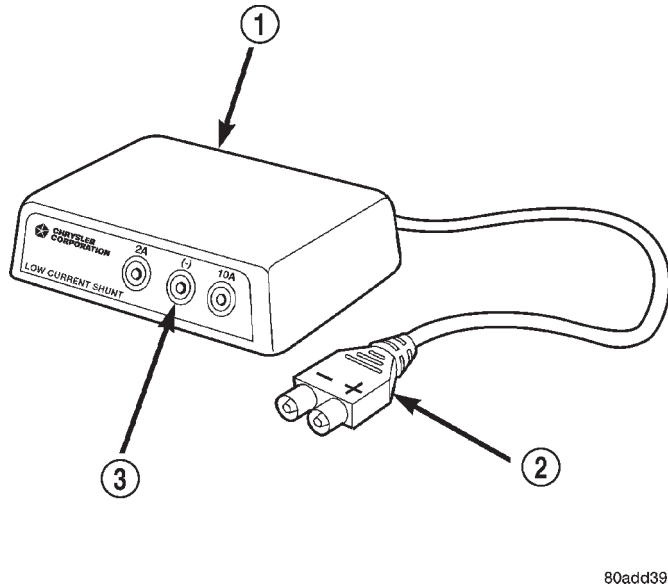
This amperage (current draw) test is to be done in conjunction with the Fuel Pump Pressure Test, Fuel Pump Capacity Test and Fuel Pressure Leak Down Test. Before performing the amperage test, be sure



DIAGNOSIS AND TESTING (Continued)

the temperature of the fuel tank is above 50° F (10° C).

The DRB Scan Tool along with the DRB Low Current Shunt (LCS) adapter (Fig. 9) and its test leads will be used to check fuel pump amperage specifications.



80add391

**Fig. 9 Low Current Shunt Adapter**

- 1 - LOW CURRENT SHUNT ADAPTER
- 2 - PLUG TO DRB
- 3 - TEST LEAD RECEPTACLES

- (1) Obtain LCS adapter.
- (2) Plug cable from LCS adapter into DRB scan tool at SET 1 receptacle.
- (3) Plug DRB into vehicle 16-way connector (data link connector).
- (4) Connect (-) and (+) test cable leads into LCS adapter receptacles. Use **10 amp (10A +)** receptacle and common (-) receptacles.
- (5) Gain access to MAIN MENU on DRB screen.
- (6) Press DVOM button on DRB.
- (7) Using left/right arrow keys, highlight CHANNEL 1 function on DRB screen.
- (8) Press ENTER three times.
- (9) Using up/down arrow keys, highlight RANGE on DRB screen (screen will default to 2 amp scale).
- (10) Press ENTER to change 2 amp scale to 10 amp scale. **This step must be done to prevent damage to DRB scan tool or LCS adapter (blown fuse).**
- (11) Remove cover from Power Distribution Center (PDC).
- (12) Remove fuel pump relay from PDC. Refer to label on PDC cover for relay location.

**WARNING: BEFORE PROCEEDING TO NEXT STEP, NOTE THE FUEL PUMP WILL BE ACTIVATED AND SYSTEM PRESSURE WILL BE PRESENT. THIS WILL OCCUR AFTER CONNECTING TEST LEADS FROM LCS ADAPTER INTO FUEL PUMP RELAY CAVITIES. THE FUEL PUMP WILL OPERATE EVEN WITH IGNITION KEY IN OFF POSITION. BEFORE ATTACHING TEST LEADS, BE SURE ALL FUEL LINES AND FUEL SYSTEM COMPONENTS ARE CONNECTED.**

**CAUTION: TO PREVENT POSSIBLE DAMAGE TO THE VEHICLE ELECTRICAL SYSTEM AND LCS ADAPTER, THE TEST LEADS MUST BE CONNECTED INTO RELAY CAVITIES EXACTLY AS SHOWN IN FOLLOWING STEPS.**

Depending upon vehicle model, year or engine configuration, three different types of relays may be used: Type-1, type-2 and type-3.

(13) If equipped with **type-1 relay** (Fig. 10), attach test leads from LCS adapter into PDC relay cavities number 30 and 87. For location of these cavities, refer to numbers stamped to bottom of relay (Fig. 10).

(14) If equipped with **type-2 relay** (Fig. 11), attach test leads from LCS adapter into PDC relay cavities number 30 and 87. For location of these cavities, refer to numbers stamped to bottom of relay (Fig. 11).

(15) If equipped with **type-3 relay** (Fig. 12), attach test leads from LCS adapter into PDC relay cavities number 3 and 5. For location of these cavities, refer to numbers stamped to bottom of relay (Fig. 12).

(16) When LCS adapter test leads are attached into relay cavities, fuel pump **will be activated**. Determine fuel pump amperage on DRB screen. Amperage should be below 10.0 amps. If amperage is below 10.0 amps, and specifications for the Fuel Pump Pressure, Fuel Pump Capacity and Fuel Pressure Leak Down tests were met, the fuel pump module is OK.

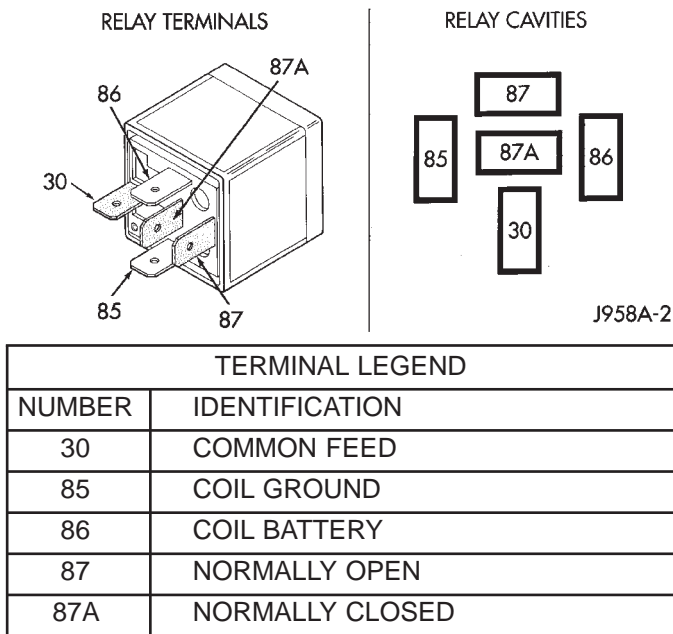
(17) If amperage is more than 10.0 amps, replace fuel pump module assembly. The electric fuel pump is not serviced separately.

(18) Disconnect test leads from relay cavities immediately after testing.

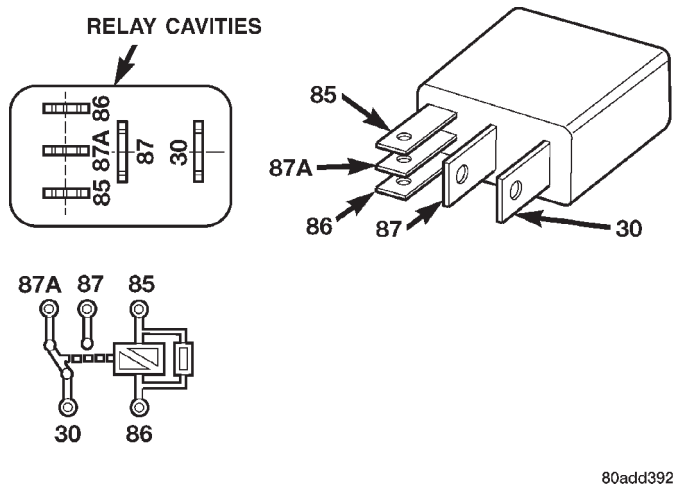
**FUEL GAUGE SENDING UNIT**

The fuel gauge sending unit contains a variable resistor (track). As the float moves up or down, electrical resistance will change. Refer to Group 8E, Instrument Panel and Gauges for Fuel Gauge testing. To test the gauge sending unit only, it must be removed from vehicle. The unit is part of the fuel pump module. Refer to Fuel Pump Module Removal/

DIAGNOSIS AND TESTING (Continued)

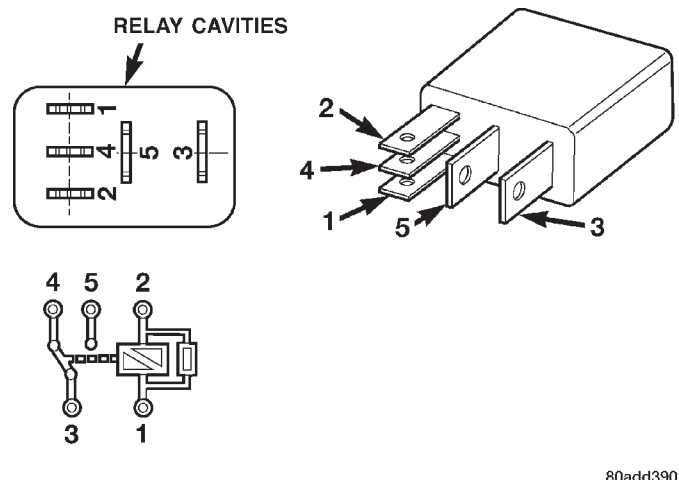


**Fig. 10 Type-1 Relay**



**Fig. 11 Type-2 Relay**

Installation for procedures. Measure the resistance across the sending unit terminals. With float in up position, resistance should be 20 ohms ±6 ohms. With float in down position, resistance should be 220 ohms ±6 ohms.



**Fig. 12 Type-3 Relay**

**FUEL INJECTOR TEST**

To perform a complete test of the fuel injectors and their circuitry, use the DRB scan tool and refer to the appropriate Powertrain Diagnostics Procedures manual. To test the injector only, refer to the following:

Disconnect the fuel injector wire harness connector from the injector. The injector is equipped with 2 electrical terminals (pins). Place an ohmmeter across the terminals. Resistance reading should be approximately 12 ohms ±1.2 ohms at 20°C (68°F).

**SERVICE PROCEDURES**

**FUEL SYSTEM PRESSURE RELEASE PROCEDURE**

**Use following procedure if the fuel injector rail is, or is not equipped with a fuel pressure test port.**

- (1) Remove fuel fill cap.
- (2) Remove fuel pump relay from Power Distribution Center (PDC). For location of relay, refer to label on underside of PDC cover.
- (3) Start and run engine until it stalls.

SERVICE PROCEDURES (Continued)

- (4) Attempt restarting engine until it will no longer run.
- (5) Turn ignition key to OFF position.

**CAUTION: Steps 1, 2, 3 and 4 must be performed to relieve high pressure fuel from within fuel rail. Do not attempt to use following steps to relieve this pressure as excessive fuel will be forced into a cylinder chamber.**

- (6) Unplug connector from any fuel injector.
- (7) Attach one end of a jumper wire with alligator clips (18 gauge or smaller) to either injector terminal.
- (8) Connect other end of jumper wire to positive side of battery.
- (9) Connect one end of a second jumper wire to remaining injector terminal.

**CAUTION: Powering an injector for more than a few seconds will permanently damage the injector.**

- (10) Momentarily touch other end of jumper wire to negative terminal of battery for no more than a few seconds.
- (11) Place a rag or towel below fuel line quick-connect fitting at fuel rail.
- (12) Disconnect quick-connect fitting at fuel rail. Refer to Quick-Connect Fittings.
- (13) Return fuel pump relay to PDC.
- (14) One or more Diagnostic Trouble Codes (DTC's) may have been stored in PCM memory due to fuel pump relay removal. The DRB scan tool must be used to erase a DTC.

**QUICK-CONNECT FITTINGS**

Also refer to Fuel Tubes/Lines/Hoses and Clamps. Different types of quick-connect fittings are used to attach various fuel system components, lines and tubes. These are: a single-tab type, a two-tab type or a plastic retainer ring type. Safety latch clips are used on certain components/lines. Certain fittings may require use of a special tool for disconnection.

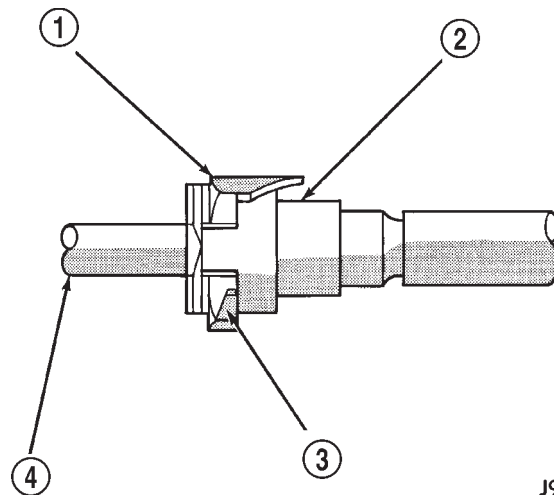
**DISCONNECTING**

**WARNING: THE FUEL SYSTEM IS UNDER A CONSTANT PRESSURE (EVEN WITH ENGINE OFF). BEFORE SERVICING ANY FUEL SYSTEM HOSE, FITTING OR LINE, FUEL SYSTEM PRESSURE MUST BE RELEASED. REFER TO FUEL SYSTEM PRESSURE RELEASE PROCEDURE.**

**CAUTION: The interior components (o-rings, spacers) of some types of quick-connect fitting are not serviced separately. If service parts are not available, do not attempt to repair a damaged fitting or**

**fuel line. If repair is necessary, replace complete fuel line assembly.**

- (1) Perform fuel pressure release procedure. Refer to Fuel Pressure Release Procedure in this group.
- (2) Disconnect negative battery cable from battery.
- (3) Clean fitting of any foreign material before disassembly.
- (4) **Single-Tab Type Fitting:** This type of fitting is equipped with a single pull tab (Fig. 13). The tab is removable. After tab is removed, quick-connect fitting can be separated from fuel system component.
  - (a) Press release tab on side of fitting to release pull tab (Fig. 14). **If release tab is not pressed prior to releasing pull tab, pull tab will be damaged.**
  - (b) While pressing release tab on side of fitting, use screwdriver to pry up pull tab (Fig. 14).
  - (c) Raise pull tab until it separates from quick-connect fitting (Fig. 15).
- (5) **Two-Tab Type Fitting:** This type of fitting is equipped with tabs located on both sides of fitting (Fig. 16). The tabs are supplied for disconnecting quick-connect fitting from component being serviced.



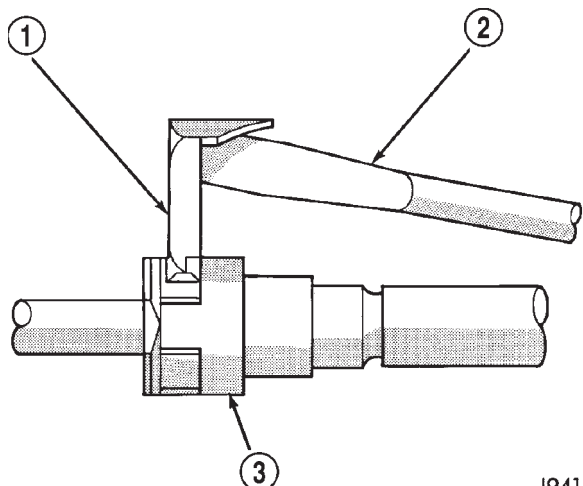
J9414-24

**Fig. 13 Single-Tab Type Fitting**

- 1 - PULL TAB
- 2 - QUICK-CONNECT FITTING
- 3 - PRESS HERE TO REMOVE PULL TAB
- 4 - INSERTED TUBE END

- (a) To disconnect quick-connect fitting, squeeze plastic retainer tabs (Fig. 16) against sides of quick-connect fitting with your fingers. Tool use is not required for removal and may damage plastic retainer.
- (b) Pull fitting from fuel system component being serviced.
- (c) The plastic retainer will remain on component being serviced after fitting is disconnected.

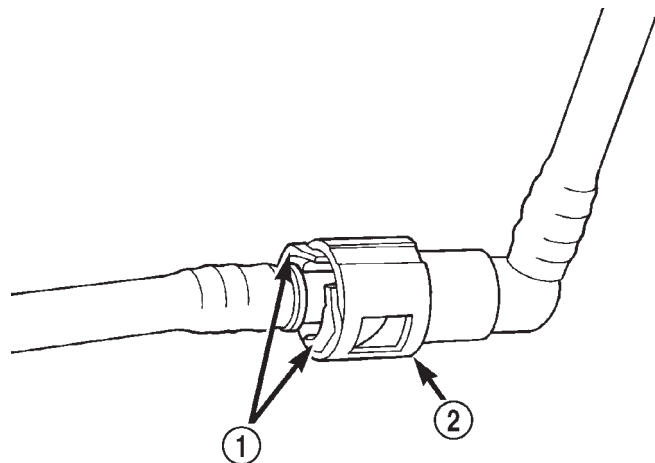
SERVICE PROCEDURES (Continued)



J9414-25

**Fig. 14 Disconnecting Single-Tab Type Fitting**

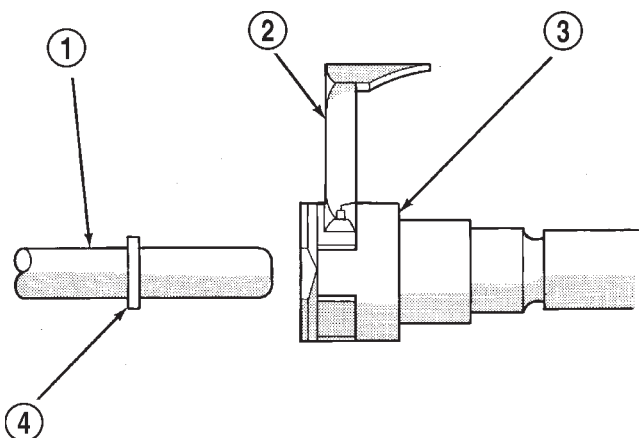
- 1 - PULL TAB
- 2 - SCREWDRIVER
- 3 - QUICK-CONNECT FITTING



80a35405

**Fig. 16 Typical Two-Tab Type Quick-Connect Fitting**

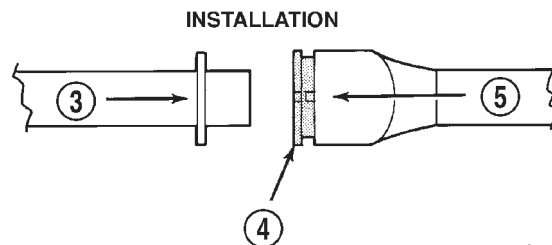
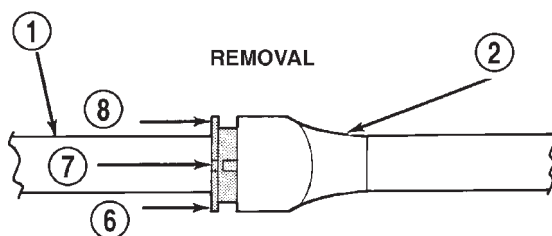
- 1 - TAB(S)
- 2 - QUICK-CONNECT FITTING



J9414-26

**Fig. 15 Removing Pull Tab**

- 1 - FUEL TUBE OR FUEL SYSTEM COMPONENT
- 2 - PULL TAB
- 3 - QUICK-CONNECT FITTING
- 4 - FUEL TUBE STOP



J9314-100

**Fig. 17 Plastic Retainer Ring Type Fitting**

- 1 - FUEL TUBE
- 2 - QUICK CONNECT FITTING
- 3 - PUSH
- 4 - PLASTIC RETAINER
- 5 - PUSH
- 6 - PUSH
- 7 - PUSH
- 8 - PUSH

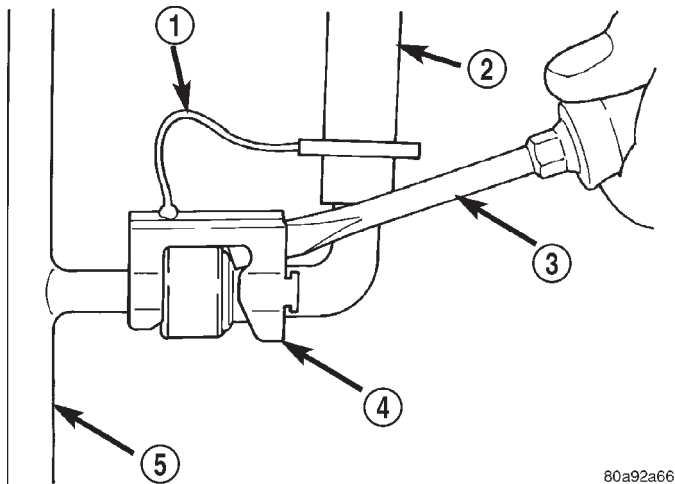
The o-rings and spacer will remain in quick-connect fitting connector body.

(6) **Plastic Retainer Ring Type Fitting:** This type of fitting can be identified by the use of a full-round plastic retainer ring (Fig. 17) usually black in color.

(a) To release fuel system component from quick-connect fitting, firmly push fitting towards component being serviced while firmly pushing plastic retainer ring into fitting (Fig. 17). With plastic ring depressed, pull fitting from component. **The plastic retainer ring must be pressed squarely into fitting body. If this retainer is cocked during removal, it may be difficult to dis-**

**nect fitting. Use an open-end wrench on shoulder of plastic retainer ring to aid in disconnection.**

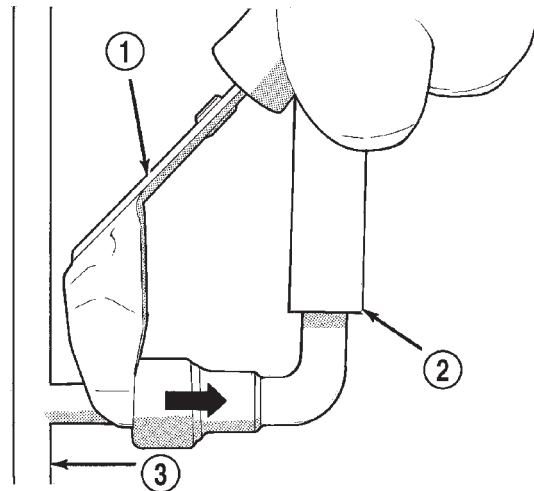
SERVICE PROCEDURES (Continued)



80a92a66

**Fig. 18 Latch Clip—Type 1**

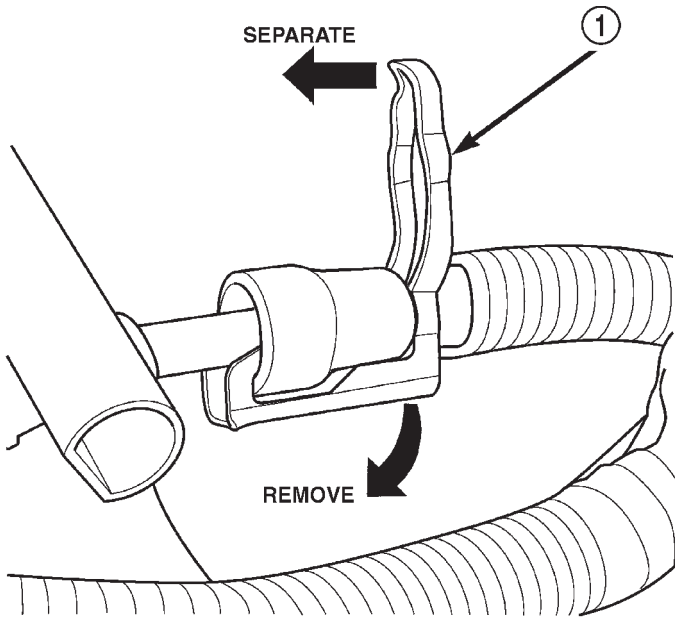
- 1 - TETHER STRAP
- 2 - FUEL LINE
- 3 - SCREWDRIVER
- 4 - LATCH CLIP
- 5 - FUEL RAIL



J9514-6

**Fig. 20 Fuel Line Disconnection Using Special Tool**

- 1 - SPECIAL FUEL LINE TOOL
- 2 - FUEL LINE
- 3 - FUEL RAIL



80b898e5

**Fig. 19 Latch Clip—Type 2**

- 1 - LATCH CLIP

(b) After disconnection, plastic retainer ring will remain with quick-connect fitting connector body.

(c) Inspect fitting connector body, plastic retainer ring and fuel system component for damage. Replace as necessary.

(7) **Latch Clips:** Depending on vehicle model and engine, 2 different types of safety latch clips are used (Fig. 18) or (Fig. 19). Type-1 is tethered to fuel line and type-2 is not. A special tool will be necessary to

disconnect fuel line after latch clip is removed. The latch clip may be used on certain fuel line/fuel rail connection, or to join fuel lines together.

(a) Type 1: Pry up on latch clip with a screwdriver (Fig. 18).

(b) Type 2: Separate and unlatch 2 small arms on end of clip (Fig. 19) and swing away from fuel line.

(c) Slide latch clip toward fuel rail while lifting with screwdriver.

(d) Insert special fuel line removal tool (Snap-On number FIH 9055-1 or equivalent) into fuel line (Fig. 20). Use tool to release locking fingers in end of line.

(e) With special tool still inserted, pull fuel line from fuel rail.

(f) After disconnection, locking fingers will remain within quick-connect fitting at end of fuel line.

(8) Disconnect quick-connect fitting from fuel system component being serviced.

**CONNECTING**

(1) Inspect quick-connect fitting body and fuel system component for damage. Replace as necessary.

(2) Prior to connecting quick-connect fitting to component being serviced, check condition of fitting and component. Clean parts with a lint-free cloth. Lubricate with clean engine oil.

(3) Insert quick-connect fitting into fuel tube or fuel system component until built-on stop on fuel tube or component rests against back of fitting.

(4) Continue pushing until a click is felt.

(5) Single-tab type fitting: Push new tab down until it locks into place in quick-connect fitting.

## SERVICE PROCEDURES (Continued)

(6) Verify a locked condition by firmly pulling on fuel tube and fitting (15-30 lbs.).

(7) Latch Clip Equipped: Install latch clip (snaps into position). **If latch clip will not fit, this indicates fuel line is not properly installed to fuel rail (or other fuel line). Recheck fuel line connection.**

(8) Connect negative cable to battery.

(9) Start engine and check for leaks.

## REMOVAL AND INSTALLATION

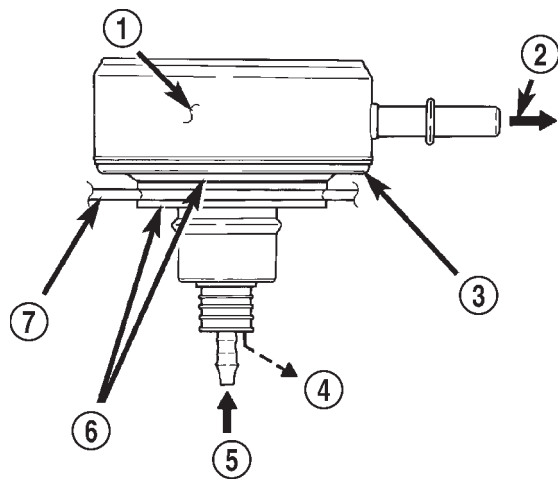
## FUEL FILTER/FUEL PRESSURE REGULATOR

## REMOVAL

**WARNING: THE FUEL SYSTEM IS UNDER A CONSTANT PRESSURE, EVEN WITH ENGINE OFF. BEFORE SERVICING THE FUEL FILTER/FUEL PRESSURE REGULATOR, THE FUEL SYSTEM PRESSURE MUST BE RELEASED.**

Refer to Fuel System Pressure Release in the Fuel Delivery System section of this group.

The fuel filter/fuel pressure regulator is located at top of fuel pump module on top of fuel tank (Fig. 22).



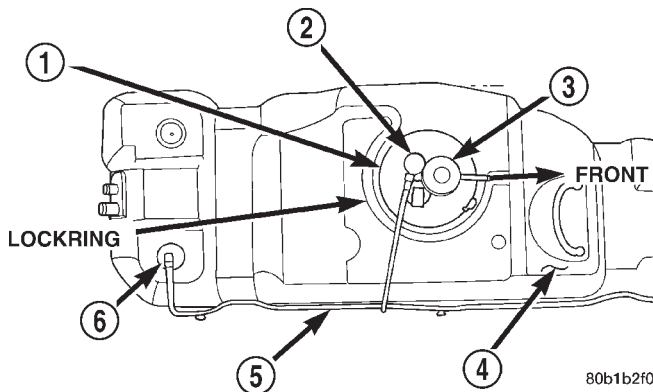
80a92a65

**Fig. 21 Fuel Filter/Fuel Pressure Regulator**

- 1 - INTERNAL FUEL FILTER
- 2 - FUEL FLOW TO FUEL INJECTORS
- 3 - FUEL FILTER/FUEL PRESSURE REGULATOR
- 4 - EXCESS FUEL BACK TO TANK
- 5 - FUEL INLET
- 6 - RUBBER GROMMET
- 7 - TOP OF PUMP MODULE

Fuel pump module removal is not necessary for filter/regulator removal.

(1) Drain fuel tank and remove tank. Refer to Fuel Tank Removal/Installation.



80b1b2f0

**Fig. 22 Filter/Regulator Location**

- 1 - FUEL PUMP MODULE
- 2 - FRONT ROLLOVER VALVE
- 3 - FUEL FILTER/FUEL PRESSURE REGULATOR
- 4 - FUEL TANK
- 5 - EVAP LINE
- 6 - REAR ROLLOVER VALVE

(2) Clean area around filter/regulator to prevent contaminants from entering pump module.

(3) The fuel filter/regulator is pressed into a rubber grommet. Remove by twisting and pulling straight up.

**CAUTION: Do not pull filter/regulator more than three inches from fuel pump module. Damage to coiled fuel tube (line) may result.**

(4) Gently cut old fuel tube (line) clamp (Fig. 23) taking care not to damage plastic fuel tube. Remove and discard old fuel tube clamp.

(5) Remove plastic fuel tube from filter/regulator by gently pulling downward. Remove filter/regulator from fuel pump module.

## INSTALLATION

(1) Install a new clamp over plastic fuel tube.

(2) Install filter/regulator to fuel tube. Rotate filter/regulator in fuel tube (line) (Fig. 24) until it is pointed towards front of tank (or front of vehicle).

(3) Tighten line clamp to fuel line using special Hose Clamp Pliers number C-4124 or equivalent (Fig. 24). **Do not use conventional side cutters to tighten this type of clamp.**

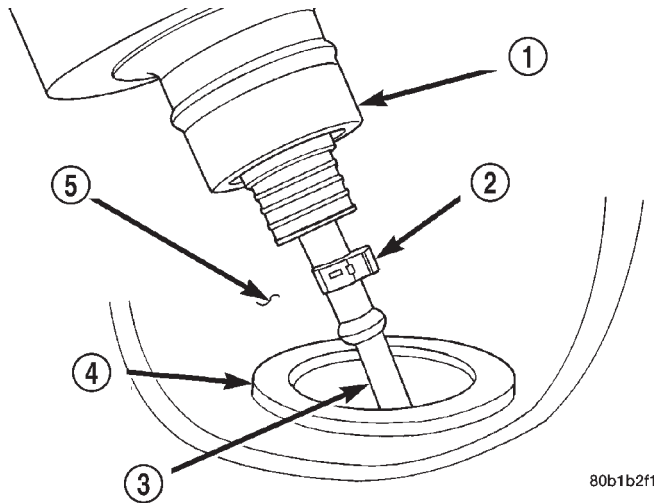
(4) Press filter/regulator (by hand) into rubber grommet.

(5) Rotate filter/regulator until pointed towards front of vehicle (Fig. 22).

(6) Install fuel tank. Refer to Fuel Tank Removal/Installation.

(7) Check for fuel leaks.

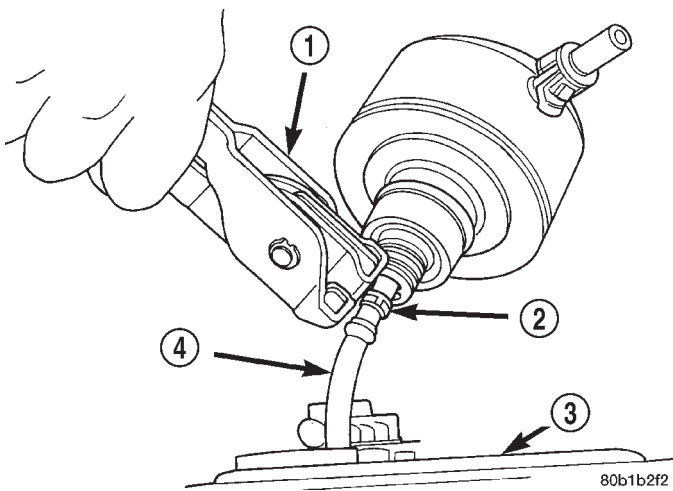
REMOVAL AND INSTALLATION (Continued)



80b1b2f1

**Fig. 23 Fuel Tube and Clamp—TYPICAL**

- 1 - FUEL FILTER/FUEL PRESSURE REGULATOR
- 2 - TUBE CLAMP
- 3 - FUEL TUBE
- 4 - RUBBER GROMMET
- 5 - TOP OF PUMP MODULE



80b1b2f2

**Fig. 24 Tightening Fuel Filter Tube Clamp—TYPICAL**

- 1 - TOOL C-4124
- 2 - TUBE CLAMP
- 3 - TOP OF PUMP MODULE
- 4 - FUEL TUBE

(1) Drain fuel tank and remove tank. Refer to Fuel Tank Removal/Installation in this group.

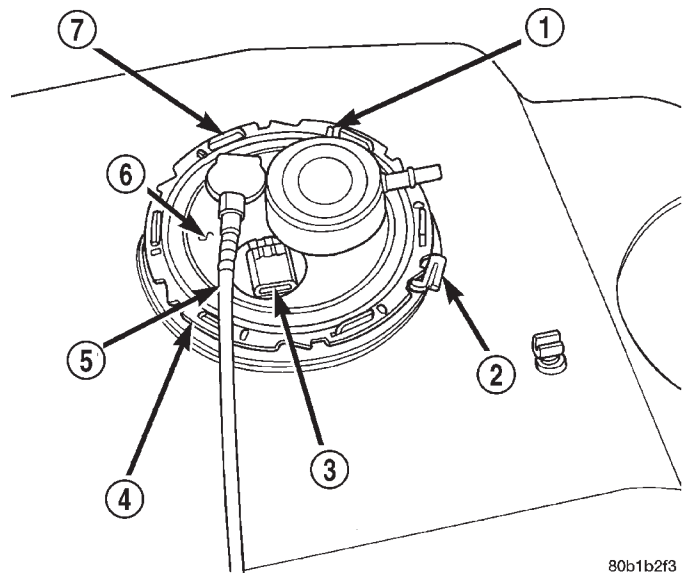
(2) Thoroughly wash and clean area around pump module to prevent contaminants from entering tank.

(3) Part of Fuel Tank Removal Procedure: Disconnect EVAP line at pump module (Fig. 25); disconnect wiring harness connector at pump module; disconnect fuel line from fuel filter fitting.

(4) Rotate fuel filter until its fitting is pointed towards center of pump module.

(5) A metal locking is used to secure fuel pump module to fuel tank (Fig. 25). Six metal fingers (Fig. 25) are molded into the plastic fuel tank. The fingers are used to retain locking to fuel tank. A rubber gasket is used as a seal between module and fuel tank.

(6) Before removing locking, apply a small amount of engine oil to 6 fingers where fingers meet locking (to act as a lubricant).



80b1b2f3

**Fig. 25 Fuel Pump Module and Lockring**

- 1 - FINGER LOCK (6)
- 2 - LOCK TAB
- 3 - ELEC. CONNec.
- 4 - LOCKRING
- 5 - EVAP LINE
- 6 - FUEL PUMP MODULE
- 7 - FINGERS (6)

**FUEL PUMP MODULE**

**REMOVAL**

**WARNING: THE FUEL SYSTEM IS UNDER A CONSTANT PRESSURE (EVEN WITH ENGINE OFF). BEFORE SERVICING FUEL PUMP MODULE, FUEL SYSTEM PRESSURE MUST BE RELEASED.**

The fuel pump module is located in top of fuel tank.

(7) Remove (rotate) locking counterclockwise using a brass or bronze drift punch and a hammer. This must be done while slightly prying back on lock tab (Fig. 25).

(8) Remove locking and pump module from fuel tank.

**INSTALLATION**

**CAUTION: Whenever fuel pump module is serviced, the module gasket must be replaced.**

## REMOVAL AND INSTALLATION (Continued)

(1) Using a new gasket, position fuel pump module into opening in fuel tank. Be sure rubber gasket remains in place. Rotate pump module assembly until module is positioned as shown in (Fig. 25). This step must be followed to prevent float/float rod from contacting sides of fuel tank.

(2) Before installing lockring, apply a small amount of engine oil to 6 fingers where fingers meet lockring (to act as a lubricant).

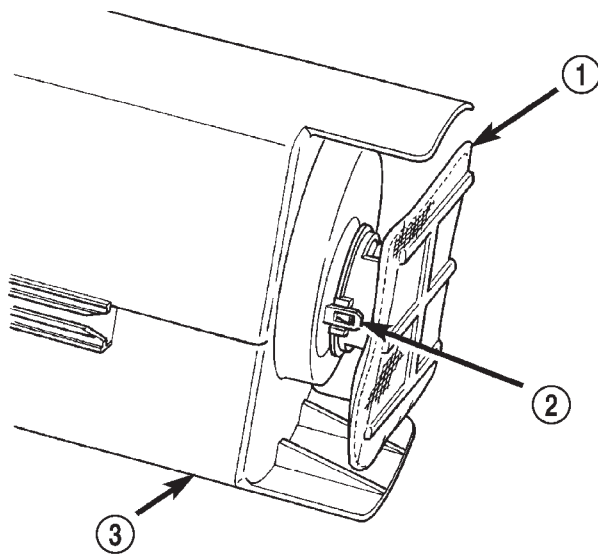
(3) Position lockring over top of fuel pump module. Tighten finger tight.

(4) Install (rotate) lockring clockwise using a brass or bronze drift punch and a hammer. Continue rotating lockring until 6 fingers (Fig. 25) drop into 6 finger locks and lock tab (Fig. 25) falls into lockring notch.

(5) Install fuel tank. Refer to Fuel Tank Installation in this section.

## FUEL PUMP INLET FILTER

The fuel pump inlet filter (strainer) is located on the bottom of the fuel pump module (Fig. 26). The fuel pump module is located inside of fuel tank.



**Fig. 26 Fuel Pump Inlet Filter**

- 1 - FUEL PUMP INLET FILTER
- 2 - LOCK TABS (2)
- 3 - FUEL PUMP MODULE (BOTTOM)

## REMOVAL

(1) Remove fuel tank. Refer to Fuel Tank Removal/Installation.

(2) Remove fuel pump module. Refer to Fuel Pump Module Removal/Installation.

(3) Remove filter by carefully prying 2 lock tabs at bottom of module with 2 screwdrivers. Filter is snapped to module.

(4) Clean bottom of pump module.

## INSTALLATION

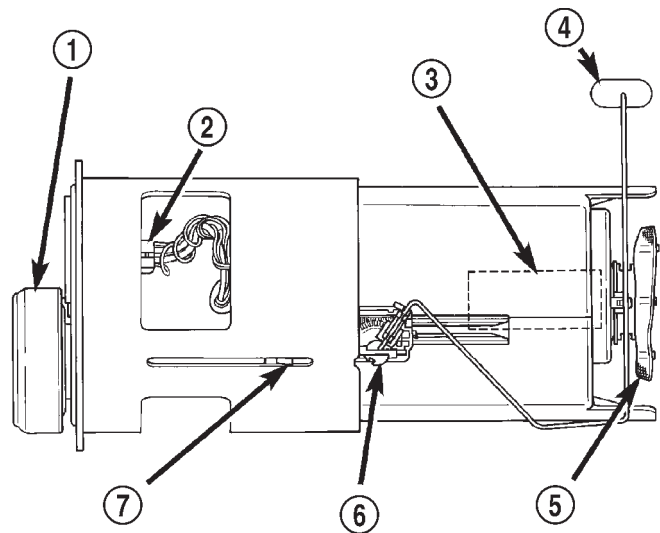
(1) Snap new filter to bottom of module. Be sure o-ring is in correct position.

(2) Install fuel pump module. Refer to Fuel Pump Module Removal/Installation.

(3) Install fuel tank. Refer to Fuel Tank Removal/Installation.

## FUEL GAUGE SENDING UNIT

The fuel gauge sending unit (fuel level sensor) and float assembly is located on the side of fuel pump module (Fig. 27). The fuel pump module is located inside of fuel tank.



80b0d725

**Fig. 27 Fuel Gauge Sending Unit Location—  
TYPICAL Module**

- 1 - FUEL FILTER/PRESSURE REGULATOR
- 2 - ELECTRICAL CONNECTOR
- 3 - ELECTRIC FUEL PUMP
- 4 - FUEL GAUGE FLOAT
- 5 - FUEL PUMP INLET FILTER
- 6 - FUEL GAUGE SENDING UNIT
- 7 - MODULE LOCK TABS (3)

## REMOVAL

(1) Remove fuel tank. Refer to Fuel Tank Removal/Installation.

(2) Remove fuel pump module. Refer to Fuel Pump Module Removal/Installation.

(3) Unplug 4-way electrical connector (Fig. 27).

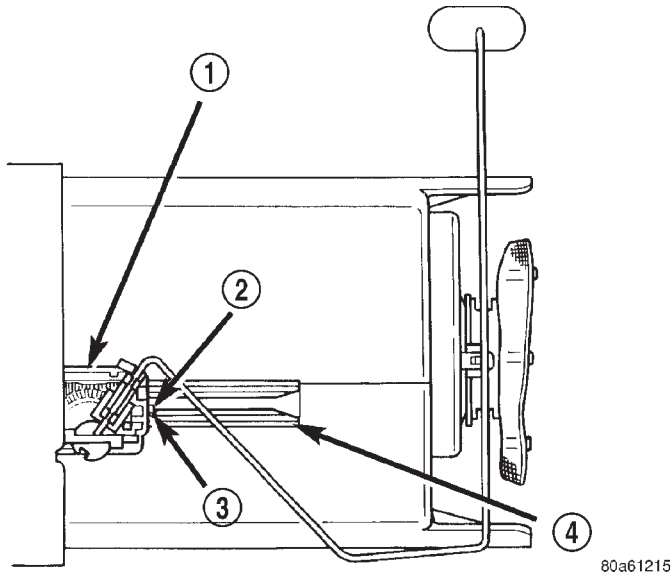
(4) Disconnect 2 sending unit wires at 4-way connector. The locking collar of connector must be removed before wires can be released from connector. Note location of wires within 4-way connector.

(5) The sending unit is retained to pump module with a small lock tab and notch (Fig. 28). Carefully push lock tab to the side and away from notch while sliding sending unit downward on tracks for removal. Note wire routing while removing unit from module.

80a61216



REMOVAL AND INSTALLATION (Continued)



**Fig. 28 Fuel Gauge Sending Unit Lock Tab/Tracks**

- 1 - FUEL GAUGE SENDING UNIT
- 2 - LOCK TAB
- 3 - NOTCH
- 4 - TRACKS

**INSTALLATION**

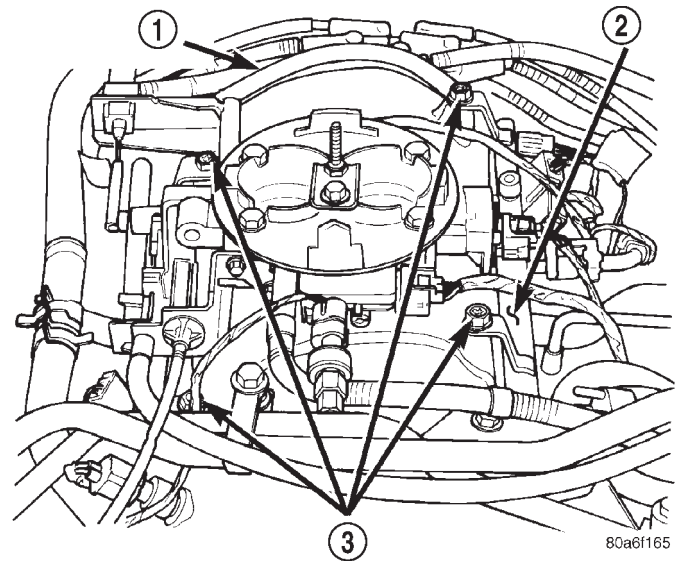
- (1) Position sending unit into tracks. Note wire routing.
- (2) Push unit on tracks until lock tab snaps into notch.
- (3) Connect 2 sending unit wires into 4-way connector and install locking collar.
- (4) Connect 4-way electrical connector to module.
- (5) Install fuel pump module. Refer to Fuel Pump Module Removal/Installation.
- (6) Install fuel tank. Refer to Fuel Tank Removal/Installation.

**FUEL INJECTOR RAIL—3.9/5.2/5.9L ENGINES**

**WARNING: THE FUEL SYSTEM IS UNDER A CONSTANT PRESSURE (EVEN WITH ENGINE TURNED OFF). BEFORE SERVICING FUEL RAIL ASSEMBLY, FUEL SYSTEM PRESSURE MUST BE RELEASED.**

To release fuel pressure, refer to Fuel System Pressure Release Procedure in this group.

**CAUTION:** The left and right fuel rails are replaced as an assembly. Do not attempt to separate rail halves at connecting hose (Fig. 29). Due to the design of this connecting hose, it does not use any clamps. Never attempt to install a clamping device of any kind to hose. When removing fuel rail assembly for any reason, be careful not to bend or kink connecting hose.

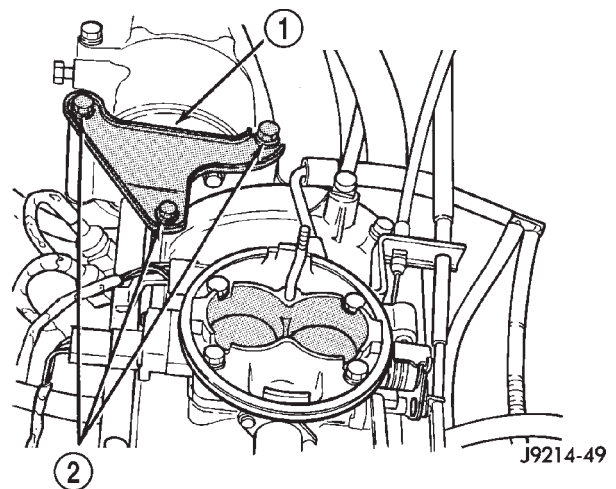


**Fig. 29 Fuel Rail Assembly—3.9/5.2/5.9L Engine—Typical**

- 1 - FUEL RAIL CONNECTING HOSE
- 2 - FUEL RAIL
- 3 - MOUNTING BOLTS (4)

**REMOVAL**

- (1) Remove negative battery cable at battery.
- (2) Remove air cleaner.
- (3) Perform fuel pressure release procedure.
- (4) Remove throttle body from intake manifold. Refer to Throttle Body removal in this group.
- (5) If equipped with air conditioning, remove A-shaped A/C compressor-to-intake manifold support bracket (three bolts) (Fig. 30).

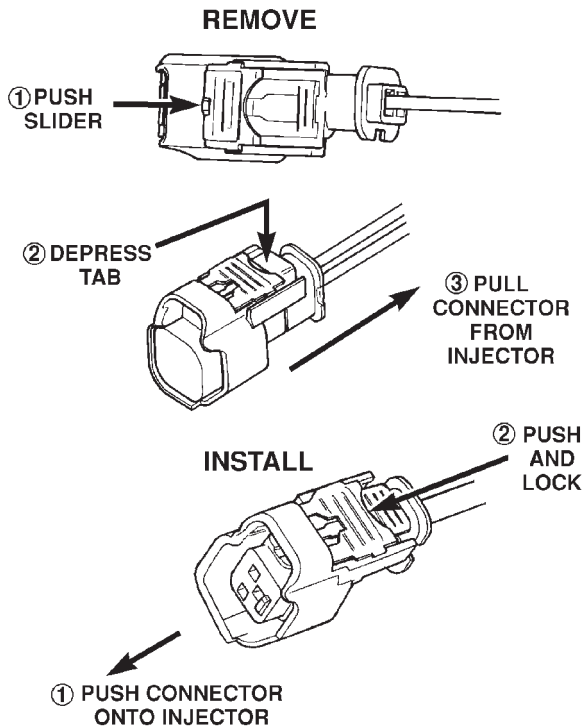


**Fig. 30 A/C Compressor Support Bracket—Typical**

- 1 - AIR CONDITIONING COMPRESSOR SUPPORT BRACKET
- 2 - MOUNTING BOLTS

- (6) Disconnect electrical connectors at all 8 fuel injectors. To remove connector refer to (Fig. 31). Push

## REMOVAL AND INSTALLATION (Continued)



80b6f033

**Fig. 31 Remove/Install Injector Connector**

red colored slider away from injector (1). While pushing slider, depress tab (2) and remove connector (3) from injector. The factory fuel injection wiring harness is numerically tagged (INJ 1, INJ 2, etc.) for injector position identification. If harness is not tagged, note wiring location before removal.

(7) 3.9L (V-6) engine only: Disconnect electrical connector at intake manifold air temperature sensor. Do not remove sensor.

(8) Disconnect fuel tube (line) at side of fuel rail. Refer to Quick-Connect Fittings for procedures,

(9) Remove remaining fuel rail mounting bolts.

(10) Clean dirt/debris from each fuel injector at intake manifold.

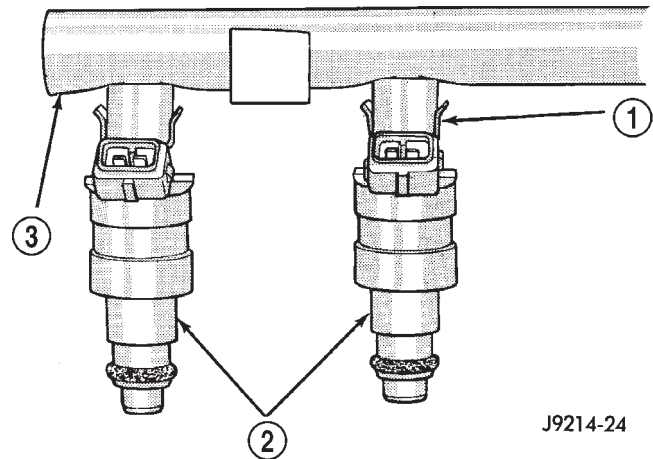
(11) Gently rock and pull **left** fuel rail until fuel injectors just start to clear intake manifold. Gently rock and pull **right** fuel rail until fuel injectors just start to clear intake manifold. Repeat this procedure (left/right) until all fuel injectors have cleared intake manifold.

(12) Remove fuel rail (with injectors attached) from engine.

(13) Remove clip(s) retaining injector(s) to fuel rail (Fig. 32) or (Fig. 33).

**INSTALLATION**

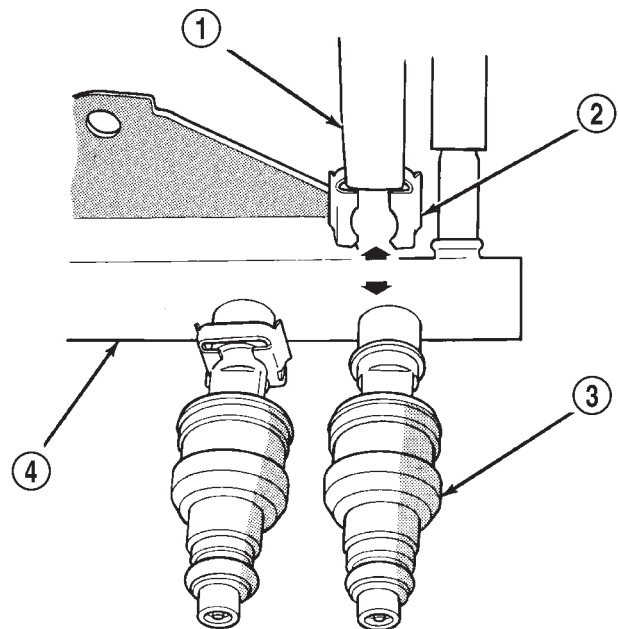
(1) Apply a small amount of clean engine oil to each fuel injector o-ring. This will help in fuel rail installation.



J9214-24

**Fig. 32 Fuel Injector Mounting—Typical**

- 1 - CLIP
- 2 - INJECTOR
- 3 - FUEL RAIL



J9414-156

**Fig. 33 Injector Retaining Clips—Typical Injector**

- 1 - PLIERS
- 2 - INJECTOR CLIP
- 3 - FUEL INJECTOR
- 4 - FUEL RAIL

(2) Install injector(s) and injector clip(s) to fuel rail.

(3) Position fuel rail/fuel injector assembly to injector openings on intake manifold.

(4) Guide each injector into intake manifold. Be careful not to tear injector o-ring.

(5) Push **right** fuel rail down until fuel injectors have bottomed on injector shoulder. Push **left** fuel

REMOVAL AND INSTALLATION (Continued)

rail down until fuel injectors have bottomed on injector shoulder.

- (6) Install fuel rail mounting bolts.
- (7) Connect electrical connector to intake manifold air temperature sensor.
- (8) Connect electrical connectors at all fuel injectors. To install connector, refer to (Fig. 31). Push connector onto injector (1) and then push and lock red colored slider (2). Verify connector is locked to injector by lightly tugging on connector.
- (9) Install A/C support bracket (if equipped).
- (10) Install throttle body to intake manifold. Refer to Throttle Body installation in this group.
- (11) Install fuel tube (line) at side of fuel rail. Refer to Quick-Connect Fittings for procedures.
- (12) Install air cleaner.
- (13) Connect battery cable to battery.
- (14) Start engine and check for leaks.

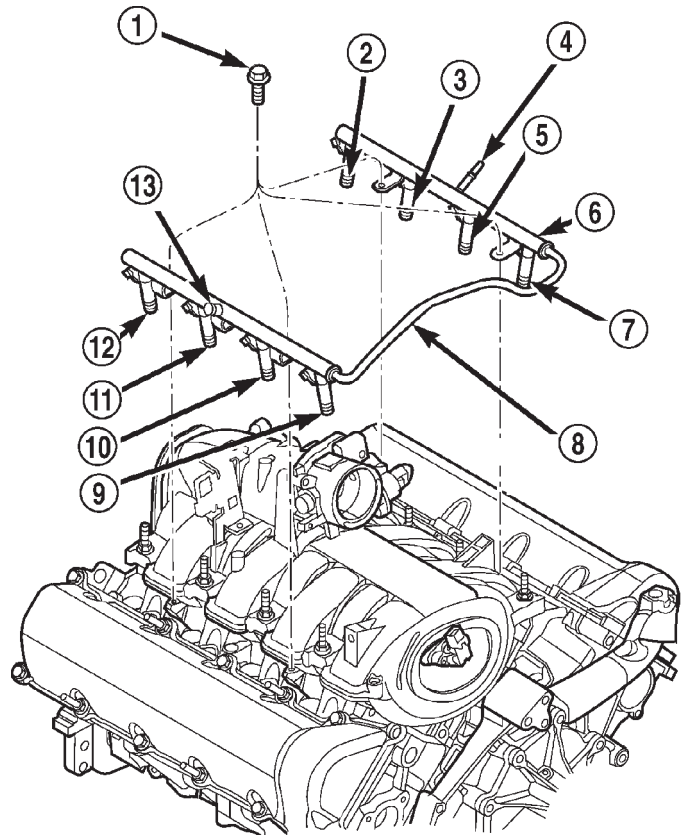
FUEL INJECTOR RAIL—4.7L V-8 ENGINE

**WARNING: THE FUEL SYSTEM IS UNDER CONSTANT PRESSURE EVEN WITH ENGINE OFF. BEFORE SERVICING FUEL RAIL, FUEL SYSTEM PRESSURE MUST BE RELEASED.**

**CAUTION: The left and right fuel rails are replaced as an assembly. Do not attempt to separate rail halves at connector tube (Fig. 34). Due to design of tube, it does not use any clamps. Never attempt to install a clamping device of any kind to tube. When removing fuel rail assembly for any reason, be careful not to bend or kink tube.**

REMOVAL

- (1) Remove fuel tank filler tube cap.
- (2) Perform Fuel System Pressure Release Procedure.
- (3) Remove negative battery cable at battery.
- (4) Remove air duct at throttle body air box.
- (5) Remove air box at throttle body.
- (6) Remove wiring at rear of generator.
- (7) Disconnect fuel line latch clip and fuel line at fuel rail. A special tool will be necessary for fuel line disconnection. Refer to Quick-Connect Fittings.
- (8) Remove vacuum lines at throttle body.
- (9) Disconnect electrical connectors at all 8 fuel injectors. To remove connector refer to (Fig. 35). Push red colored slider away from injector (1). While pushing slider, depress tab (2) and remove connector (3) from injector. The factory fuel injection wiring harness is numerically tagged (INJ 1, INJ 2, etc.) for injector position identification. If harness is not tagged, note wiring location before removal.



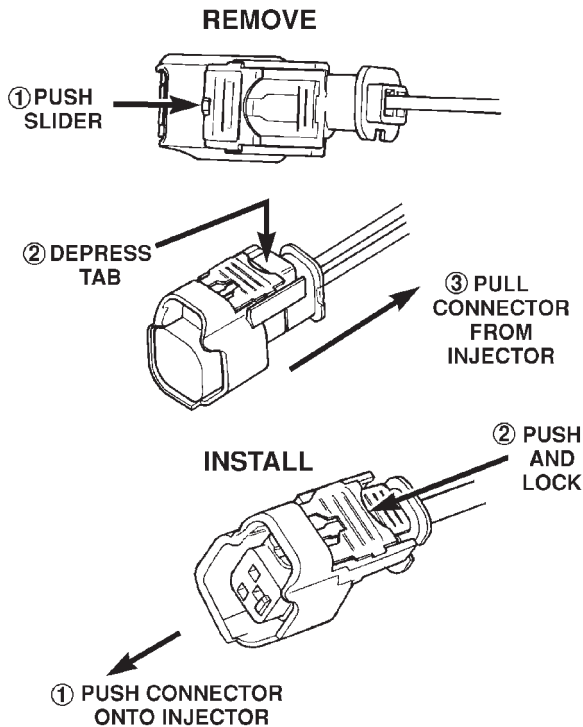
80b898e4

**Fig. 34 Fuel Rail Mounting—4.7L V-8 Engine**

- 1 - MOUNTING BOLTS (4)
- 2 - INJ.#7
- 3 - INJ.#5
- 4 - QUICK-CONNECT FITTING
- 5 - INJ.#3
- 6 - FUEL INJECTOR RAIL
- 7 - INJ.#1
- 8 - CONNECTOR TUBE
- 9 - INJ.#2
- 10 - INJ.#4
- 11 - INJ.#6
- 12 - INJ.#8
- 13 - PRESSURE TEST PORT CAP

- (10) Disconnect electrical connectors at throttle body.
- (11) Disconnect electrical connectors at MAP and IAT sensors.
- (12) Remove first three ignition coils on each bank (cylinders #1, 3, 5, 2, 4 and 6). Refer to Ignition Coil Removal/Installation.
- (13) Remove 4 fuel rail mounting bolts (Fig. 34).
- (14) Gently rock and pull **left** side of fuel rail until fuel injectors just start to clear machined holes in cylinder head. Gently rock and pull **right** side of rail until injectors just start to clear cylinder head holes. Repeat this procedure (left/right) until all injectors have cleared cylinder head holes.

## REMOVAL AND INSTALLATION (Continued)



80b6f033

**Fig. 35 Remove/Install Injector Connector—4.7L V-8 Engine**

(15) Remove fuel rail (with injectors attached) from engine.

(16) If fuel injectors are to be removed, refer to Fuel Injector Removal/Installation.

### INSTALLATION

(1) If fuel injectors are to be installed, refer to Fuel Injector Removal/Installation.

(2) Apply a small amount of engine oil to each fuel injector o-ring. This will help in fuel rail installation.

(3) Position fuel rail/fuel injector assembly to machined injector openings in cylinder head.

(4) Guide each injector into cylinder head. Be careful not to tear injector o-rings.

(5) Push **right** side of fuel rail down until fuel injectors have bottomed on cylinder head shoulder. Push **left** fuel rail down until injectors have bottomed on cylinder head shoulder.

(6) Install 4 fuel rail mounting bolts and tighten to 27 N·m (20 ft. lbs.).

(7) Install ignition coils. Refer to Ignition Coil Removal/Installation.

(8) Connect electrical connectors to throttle body.

(9) Connect electrical connectors to MAP and IAT sensors.

(10) Connect electrical connectors at all fuel injectors. To install connector, refer to (Fig. 35). Push connector onto injector (1) and then push and lock red

colored slider (2). Verify connector is locked to injector by lightly tugging on connector.

(11) Connect vacuum lines to throttle body.

(12) Connect fuel line latch clip and fuel line to fuel rail. Refer to Quick-Connect Fittings.

(13) Connect wiring to rear of generator.

(14) Install air box to throttle body.

(15) Install air duct to air box.

(16) Connect battery cable to battery.

(17) Start engine and check for leaks.

### FUEL INJECTOR(S)

**WARNING: THE FUEL SYSTEM IS UNDER A CONSTANT PRESSURE EVEN WITH ENGINE TURNED OFF. BEFORE SERVICING FUEL INJECTOR(S), FUEL SYSTEM PRESSURE MUST BE RELEASED.**

To release fuel pressure, refer to Fuel System Pressure Release Procedure.

To remove one or more fuel injectors, fuel rail assembly must be removed from engine.

### REMOVAL

(1) Remove air cleaner assembly.

(2) Remove fuel injector rail assembly. Refer to Fuel Injector Rail Removal/Installation in this group.

(3) Remove clip(s) retaining the injector(s) to fuel rail (Fig. 32) or (Fig. 33).

(4) Remove injector(s) from fuel rail.

### INSTALLATION

(1) Apply a small amount of clean engine oil to each fuel injector o-ring. This will help in fuel rail installation.

(2) Install injector(s) and injector clip(s) to fuel rail.

(3) Install fuel rail assembly. Refer to Fuel Injector Rail Removal/Installation.

(4) Install air cleaner.

(5) Start engine and check for leaks.

### FUEL TANK

**WARNING: THE FUEL SYSTEM IS UNDER A CONSTANT PRESSURE (EVEN WITH ENGINE OFF). BEFORE DRAINING FUEL TANK, FUEL SYSTEM PRESSURE MUST BE RELEASED.**

Two different procedures may be used to drain fuel tank (removing fuel vent hose at fuel tank or using DRB scan tool).

The quickest draining procedure involves removing fuel vent hose at fuel tank.

As an alternative procedure, the electric fuel pump may be activated allowing tank to be drained at fuel rail connection. Refer to DRB scan tool for fuel pump

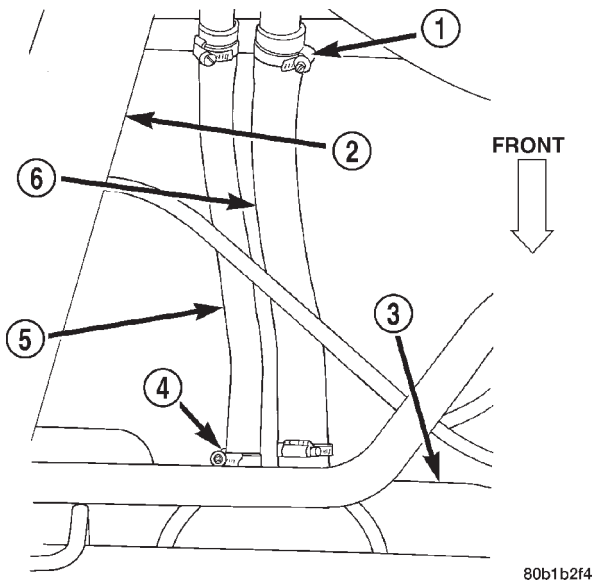
REMOVAL AND INSTALLATION (Continued)

activation procedures. Before disconnecting fuel line at fuel rail, release fuel pressure. Refer to the Fuel System Pressure Release Procedure in this group for procedures. Attach end of special test hose tool number 6541, 6539, 6631 or 6923 at fuel rail disconnection (tool number will depend on model and/or engine application). Position opposite end of this hose tool to an approved gasoline draining station. Activate fuel pump and drain tank until empty.

If electric fuel pump is not operating, tank **must** be drained by removing fuel vent hose. Refer to following procedures.

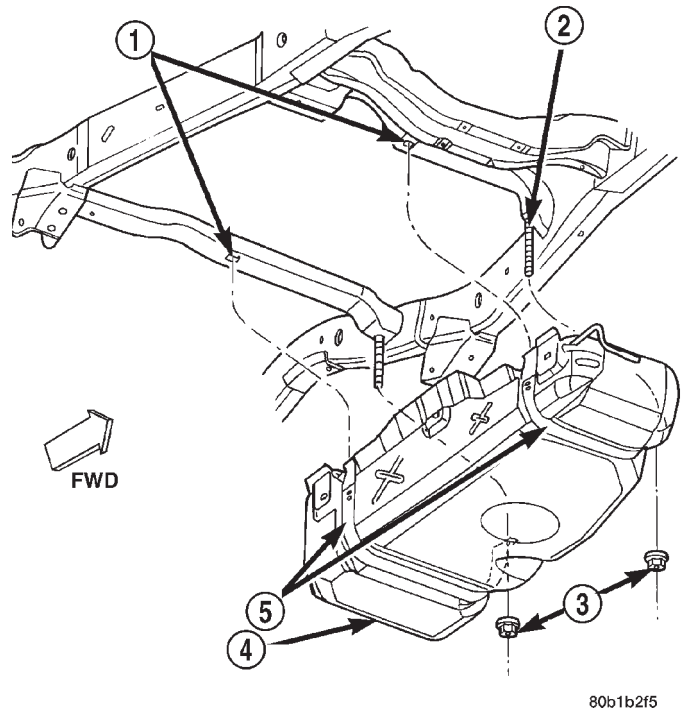
**REMOVAL**

- (1) Perform Fuel System Pressure Release procedure as described in this group.
- (2) Disconnect negative battery cable at battery.
- (3) Remove fuel tank filler tube cap.
- (4) Raise vehicle on hoist.
- (5) If equipped, remove fuel tank skid plate. Refer to Fuel Tank Skid Plate in Group 23, Body.
- (6) Two rubber hoses (fuel filler and fuel vent hoses) connect the fuel tank fittings (at rear of tank) to the metal fuel fill tube assembly at body (Fig. 36). Disconnect hose clamps (Fig. 36) at fuel fill tube assembly end of hoses and disconnect rubber hoses.
- (7) Position a drain hose into the fuel vent hose (Fig. 36) and into tank.
- (8) Drain fuel into an approved portable holding tank or a properly labeled gasoline safety container.



**Fig. 36 Fuel Hoses at Rear of Fuel Tank**

- 1 - CLAMPS
- 2 - L.R. SHOCK ABSORBER
- 3 - FUEL TANK
- 4 - CLAMPS
- 5 - FUEL VENT HOSE
- 6 - FUEL FILL HOSE



**Fig. 37 Fuel Tank Mounting**

- 1 - STRAP MOUNTING HOLES (2)
- 2 - TANK MOUNTING STUDS (2)
- 3 - TANK NUTS (2)
- 4 - FUEL TANK
- 5 - TANK STRAPS (2)

- (9) Place and secure a transmission jack under center of fuel tank and apply slight pressure.
- (10) Remove two tank mounting nuts from mounting straps (Fig. 37). Position tank mounting straps to side of vehicle and lower tank just enough to allow access to connections at top of tank. **To prevent fuel loss, be sure rear of tank is higher than front of tank when lowering.**
- (11) Clean quick-connect fittings (at top of fuel tank) of any dirt/contaminants before removal.
- (12) Disconnect fuel supply line from fuel filter/fuel pressure regulator fitting at top of tank. Refer to Quick-Connect Fittings for procedures.
- (13) Disconnect rear fuel vapor line (EVAP line) from rollover valve at top/rear of tank.
- (14) Disconnect front fuel vapor line (EVAP line) from rollover valve at fuel pump module.
- (15) Disconnect electrical connector from pump module at top of tank.
- (16) Lower tank from vehicle.
- (17) Remove tank from hydraulic jack.
- (18) If fuel pump module requires service, refer to Fuel Pump Module Removal/Installation.

## REMOVAL AND INSTALLATION (Continued)

## INSTALLATION

(1) If fuel pump module is being installed, refer to Fuel Pump Module Removal/Installation. Be sure fuel filter/fuel pressure regulator inlet fitting is pointed towards front of vehicle.

(2) Place and secure fuel tank on top of transmission jack.

(3) Raise tank up enough to connect fuel line, electrical connector and both EVAP lines to top of fuel tank. Refer to Quick-Connect Fittings for fuel line procedures.

(4) Continue raising tank into position and install mounting straps and nuts. Tighten nuts to 27–54 N·m (20–40 ft. lbs.) torque. **Do not over tighten mounting strap nuts.**

(5) Remove transmission jack.

(6) Connect fill/vent hoses to fill/vent tube assembly.

(7) Tighten hose clamps at fill/vent hoses.

(8) If equipped, install fuel tank skid plate. Refer to Fuel Tank Skid Plate in Group 23, Body.

(9) Connect negative cable to battery.

(10) Refill fuel tank and install fill cap.

(11) Inspect all hoses and lines for leaks.

## FUEL TANK FILLER TUBE CAP

## REMOVAL/INSTALLATION

If replacement of the 1/4 turn fuel tank filler tube cap is necessary, it must be replaced with an identical cap to be sure of correct system operation.

**CAUTION:** Remove the fuel tank filler tube cap to relieve fuel tank pressure. The cap must be removed prior to disconnecting any fuel system component or before draining the fuel tank.

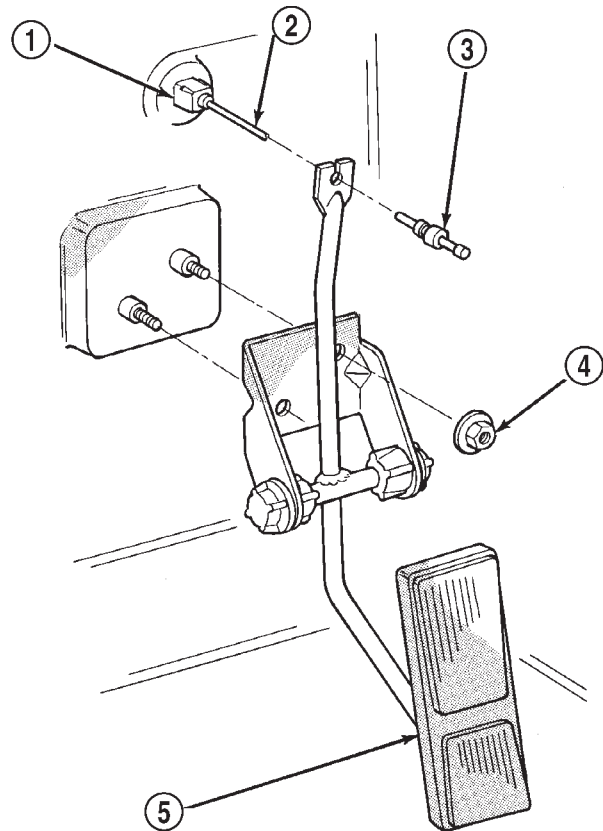
## ACCELERATOR PEDAL

All engines are equipped with torsion return springs located on the throttle body shaft. 3.9L V-6 and 5.2/5.9L V-8 engines equipped with a manual transmission have an additional pedal return spring on the throttle body linkage.

## REMOVAL

**CAUTION:** Be careful not to damage or kink the cable core wire (within the cable sheathing) while servicing accelerator pedal or cables.

(1) From inside the vehicle, hold up accelerator pedal. Remove plastic cable retainer and throttle cable core wire from upper end of pedal arm (Fig. 38). Plastic cable retainer snaps into pedal arm.



J9314-103

**Fig. 38 Accelerator Pedal—Removal or Installation**

- 1 - PINCH SIDES
- 2 - CABLE
- 3 - CABLE RETAINER
- 4 - NUTS (2)
- 5 - ACCELERATOR PEDAL

(2) Remove two accelerator pedal/bracket nuts (Fig. 38) and remove pedal/bracket assembly from vehicle.

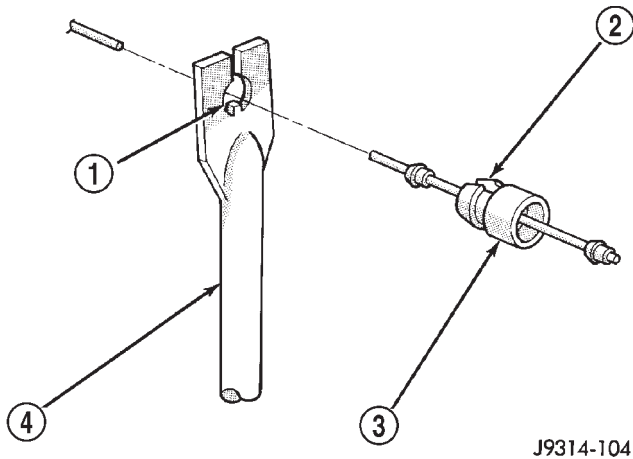
## INSTALLATION

(1) Position pedal/bracket assembly over the two dash panel mounting studs and install retaining nuts.

(2) Tighten nuts to 7 N·m (65 in. lbs.) torque.

(3) From inside the vehicle, hold up the accelerator pedal. Install the throttle cable core wire and plastic cable retainer into the upper end of the pedal arm. The plastic retainer is snapped into the pedal arm. When installing the plastic retainer to the accelerator pedal arm, note the index tab on the pedal arm (Fig. 39). Align the index slot (Fig. 39) on the plastic cable retainer to this index tab.

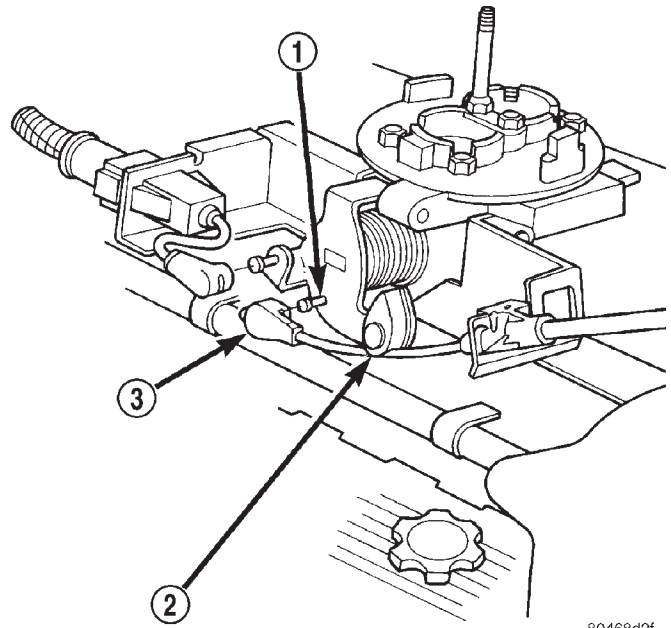
REMOVAL AND INSTALLATION (Continued)



J9314-104

**Fig. 39 Index Tab and Slot**

- 1 - INDEX TAB
- 2 - INDEX SLOT
- 3 - CABLE RETAINER
- 4 - PEDAL ARM



80468d2f

**Fig. 40 Throttle Cable at Throttle Body—Typical (V-8 Shown)**

- 1 - THROTTLE LEVER PIN
- 2 - CAM (V-8 ENGINE ONLY)
- 3 - THROTTLE CABLE END

**THROTTLE CABLE**

**CAUTION:** Be careful not to damage or kink cable core wire (within cable sheathing) while servicing accelerator pedal or cables.

**REMOVAL**

(1) From inside vehicle, hold up accelerator pedal. Remove plastic cable retainer and throttle cable core wire from upper end of pedal arm (Fig. 38). Plastic cable retainer snaps into pedal arm.

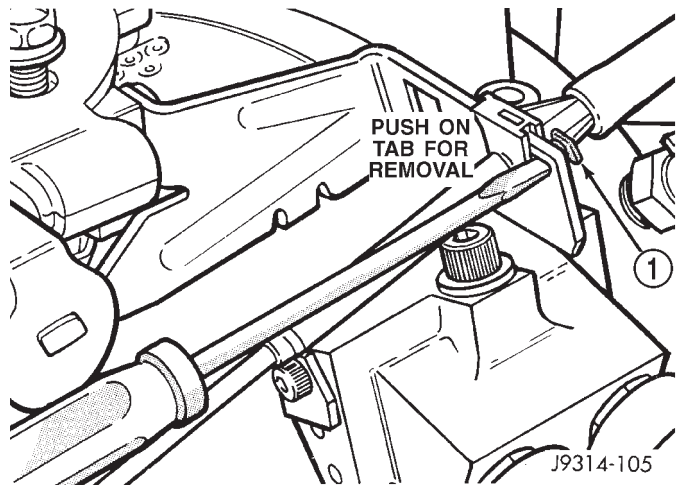
(2) Remove cable core wire at pedal arm.

(3) From inside vehicle, pinch both sides of cable housing retainer at dash panel (Fig. 38). Remove cable housing from dash panel and pull into engine compartment.

(4) Remove air tube at top of throttle body.

(5) Operate throttle body lever (by hand) to full open throttle position. Slip cable end rearward from pin on throttle lever (Fig. 40).

(6) Remove cable housing at throttle body mounting bracket by pressing forward on release tab with a small screwdriver (Fig. 41). **To prevent cable housing breakage, press on tab only enough to release cable from bracket.** Lift cable housing straight up from bracket while pressing on release tab. Remove cable housing.



J9314-105

**Fig. 41 Cable Release Tab—Typical V-6/V8 Engine**

- 1 - TAB

**INSTALLATION**

(1) Snap cable end onto lever pin (Fig. 40). On models with V-8 engines, be sure cable is routed **under** plastic cam (Fig. 40).

(2) Connect cable to throttle body mounting bracket (push down and lock).

(3) Install remaining cable housing end into dash panel opening (snaps into position).

(4) Install ball end of cable wire through hole in pedal arm. Install plastic cable retainer. The plastic retainer is snapped into pedal arm. When installing retainer to accelerator pedal arm, note index tab on pedal arm (Fig. 39). Align index slot (Fig. 39) on plastic retainer to this index tab.

(5) Operate and test throttle before starting engine.

## REMOVAL AND INSTALLATION (Continued)

- (6) Install air tube to throttle body.

## THROTTLE CABLE—4.7L V-8 ENGINE

## REMOVAL

**CAUTION:** Be careful not to damage or kink the cable core wire (within the cable sheathing) while servicing accelerator pedal or throttle cable.

(1) From inside vehicle, hold up accelerator pedal. Remove plastic cable retainer (clip) and throttle cable core wire from upper end of pedal arm (Fig. 38). Plastic cable retainer (clip) snaps into pedal arm.

(2) Remove cable core wire at pedal arm.

(3) From inside vehicle, remove clip holding cable to dashpanel (Fig. 38).

(4) Remove air box at throttle body.

(5) Unsnap cable from dashpanel routing clip.

(6) Remove cable housing from dash panel and pull into engine compartment.

(7) Using finger pressure only, disconnect accelerator cable connector at throttle body bellcrank pin by pushing connector off bellcrank pin towards front of vehicle (Fig. 42). **DO NOT try to pull connector off perpendicular to the bellcrank pin. Connector will be broken.**

(8) Lift accelerator cable from top of cable cam (Fig. 42).

(9) Press tab (Fig. 43) to release plastic cable mount from bracket. **Press on tab only enough to release cable from bracket. If tab is pressed too much, it will be broken.** Slide plastic mount (Fig. 43) towards passenger side of vehicle to remove cable from bracket.

(10) Remove throttle cable from vehicle.

## INSTALLATION

(1) Slide accelerator cable plastic mount into bracket. Continue sliding until tab (Fig. 43) is aligned to hole in mounting bracket.

(2) Route accelerator cable over top of cable cam.

(3) Connect cable end to throttle body bellcrank pin (snaps on rearward).

(4) Slide rubber grommet away from plastic cable housing.

(5) Install rubber grommet into dash panel until seated.

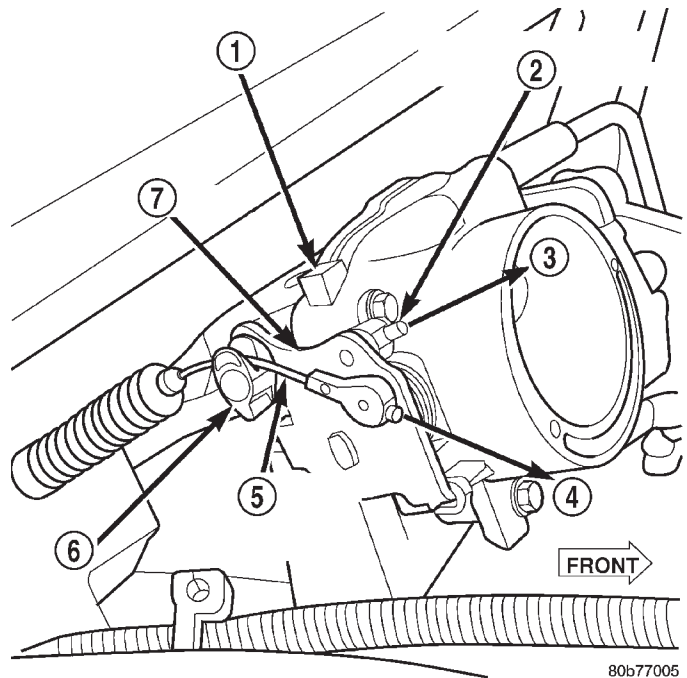
(6) Push cable housing into rubber grommet and through opening in dash panel.

(7) From inside vehicle, install clip holding cable to dashpanel (Fig. 38).

(8) From inside vehicle, slide throttle cable core wire into opening in top of pedal arm.

(9) Push cable retainer (clip) into pedal arm opening until it snaps in place.

(10) Snap cable into dashpanel routing clip.



**Fig. 42 Accelerator Cable at Bell Crank—4.7L V-8 Engine**

- 1 - THROTTLE BODY  
 2 - SPEED CONTROL CABLE CONNECTOR  
 3 - OFF  
 4 - OFF  
 5 - ACCELERATOR CABLE CONNECTOR  
 6 - CABLE CAM  
 7 - BELLCRANK

(11) Install air box to throttle body.

(12) Before starting engine, operate accelerator pedal to check for any binding.

## SPECIFICATIONS

## FUEL TANK CAPACITY

Models	Liters	U.S. Gallons
Standard	95	25
Nominal refill capacities are shown. A variation may be observed from vehicle to vehicle due to manufacturing tolerance and refill procedure.		

## FUEL SYSTEM PRESSURE

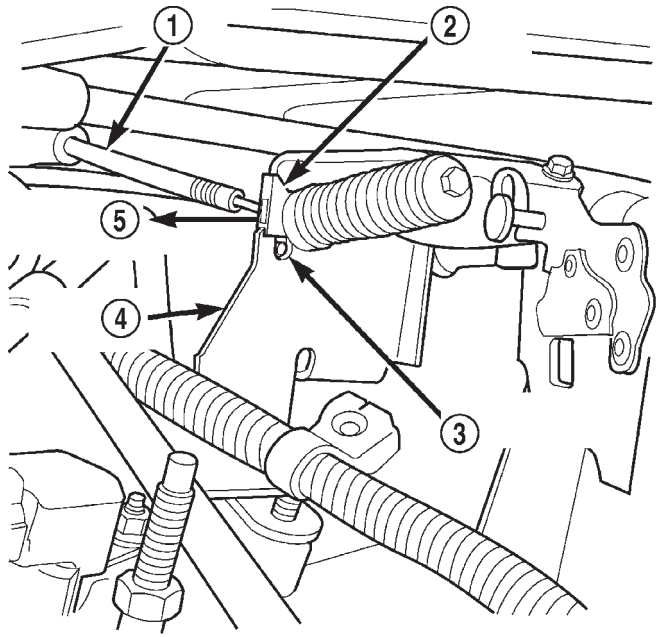
All Engines: 339 kPa  $\pm$  34 kPa (49.2 psi  $\pm$  5 psi)

## FUEL REQUIREMENTS

Your engine is designed to meet all emissions regulations and provide excellent fuel economy and performance when using high quality unleaded gasoline having an octane rating of 87. The use of premium



SPECIFICATIONS (Continued)



80b77006

**Fig. 43 Accelerator Cable Release Tab—4.7L V-8 Engine**

- 1 - ACCELERATOR CABLE
- 2 - PLASTIC CABLE MOUNT
- 3 - PRESS TAB FOR REMOVAL
- 4 - CABLE BRACKET
- 5 - SLIDE FOR REMOVAL

gasoline is not recommended. The use of premium gasoline will provide no benefit over high quality regular gasoline, and in some circumstances may result in poorer performance.

Light spark knock at low engine speeds is not harmful to your engine. However, continued heavy spark knock at high speeds can cause damage and immediate service is required. Engine damage resulting from operation with a heavy spark knock may not be covered by the new vehicle warranty.

Poor quality gasoline can cause problems such as hard starting, stalling and hesitations. If you experience these symptoms, try another brand of gasoline before considering service for the vehicle.

Over 40 auto manufacturers world-wide have issued and endorsed consistent gasoline specifications (the Worldwide Fuel Charter, WWFC) to define fuel properties necessary to deliver enhanced emissions, performance and durability for your vehicle. We recommend the use of gasolines that meet the WWFC specifications if they are available.

**REFORMULATED GASOLINE**

Many areas of the country require the use of cleaner burning gasoline referred to as “reformulated” gasoline. Reformulated gasoline contain oxygen-

ates, and are specifically blended to reduce vehicle emissions and improve air quality.

We strongly supports the use of reformulated gasoline. Properly blended reformulated gasoline will provide excellent performance and durability for the engine and fuel system components.

**GASOLINE/OXYGENATE BLENDS**

Some fuel suppliers blend unleaded gasoline with oxygenates such as 10% ethanol, MTBE, and ETBE. Oxygenates are required in some areas of the country during the winter months to reduce carbon monoxide emissions. Fuels blended with these oxygenates may be used in your vehicle.

**CAUTION: DO NOT use gasoline containing METHANOL. Gasoline containing methanol may damage critical fuel system components.**

**MMT IN GASOLINE**

MMT is a manganese-containing metallic additive that is blended into some gasoline to increase octane. Gasoline blended with MMT provide no performance advantage beyond gasoline of the same octane number without MMT. Gasoline blended with MMT reduce spark plug life and reduce emission system performance in some vehicles. We recommend that gasolines free of MMT be used in your vehicle. The MMT content of gasoline may not be indicated on the gasoline pump; therefore, you should ask your gasoline retailer whether or not his/her gasoline contains MMT.

It is even more important to look for gasoline without MMT in Canada because MMT can be used at levels higher than allowed in the United States. MMT is prohibited in Federal and California reformulated gasoline.

**SULFUR IN GASOLINE**

If you live in the northeast United States, your vehicle may have been designed to meet California low emission standards with Cleaner-Burning California reformulated gasoline with low sulfur. If such fuels are not available in states adopting California emission standards, your vehicles will operate satisfactorily on fuels meeting federal specifications, but emission control system performance may be adversely affected. Gasoline sold outside of California is permitted to have higher sulfur levels which may affect the performance of the vehicle’s catalytic converter. This may cause the Malfunction Indicator Lamp (MIL), Check Engine or Service Engine Soon light to illuminate. We recommend that you try a different brand of unleaded gasoline having lower sulfur to determine if the problem is fuel related prior to returning your vehicle to an authorized dealer for service.

SPECIFICATIONS (Continued)

**CAUTION:** If the Malfunction Indicator Lamp (MIL), Check Engine or Service Engine Soon light is flashing, immediate service is required; see on-board diagnostics system section.

**MATERIALS ADDED TO FUEL**

All gasoline sold in the United States and Canada are required to contain effective detergent additives. Use of additional detergents or other additives is not needed under normal conditions.

**FUEL SYSTEM CAUTIONS**

**CAUTION:** Follow these guidelines to maintain your vehicle's performance:

- The use of leaded gas is prohibited by Federal law. Using leaded gasoline can impair engine performance, damage the emission control system, and could result in loss of warranty coverage.
- An out-of-tune engine, or certain fuel or ignition malfunctions, can cause the catalytic converter to overheat. If you notice a pungent burning odor or some light smoke, your engine may be out of tune or malfunctioning and may require immediate service. Contact your dealer for service assistance.
- When pulling a heavy load or driving a fully loaded vehicle when the humidity is low and the temperature is high, use a premium unleaded fuel to

help prevent spark knock. If spark knock persists, lighten the load, or engine piston damage may result.

- The use of fuel additives which are now being sold as octane enhancers is not recommended. Most of these products contain high concentrations of methanol. Fuel system damage or vehicle performance problems resulting from the use of such fuels or additives is not the responsibility of Daimler-Chrysler Corporation and may not be covered under the new vehicle warranty.

**NOTE:** Intentional tampering with emissions control systems can result in civil penalties being assessed against you.

**TORQUE CHART**

<b>DESCRIPTION</b>	<b>TORQUE</b>
Accelerator Pedal Bracket	
Mounting Nuts . . . . .	7 N·m (65 in. lbs.)
Fuel Rail Mounting	
Bolts—3.9/5.2/5.9L Engines . . . . .	23 N·m (200 in. lbs.)
Fuel Tank	
Mounting Nuts . . . . .	27–54 N·m (20–40 ft. lbs.)
Fuel Hose Clamps (if equipped) . . . . .	3 N·m (25 in. lbs.)

# FUEL INJECTION SYSTEM

## TABLE OF CONTENTS

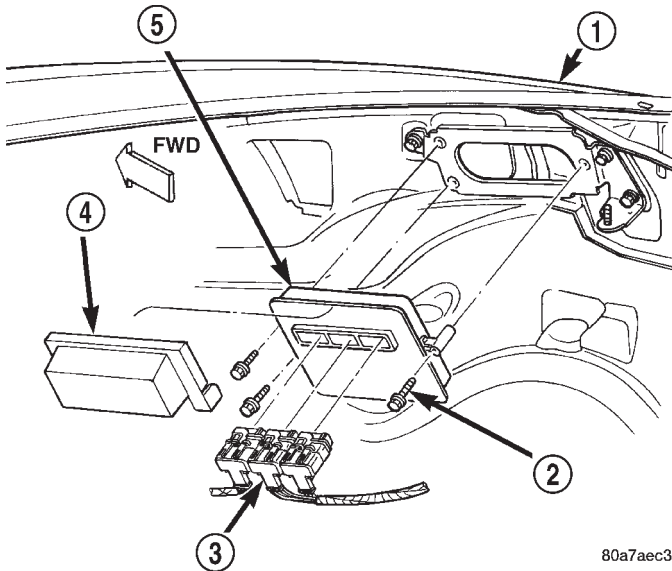
	page		page
<b>DESCRIPTION AND OPERATION</b>		<b>THROTTLE BODY</b> . . . . .	39
POWERTRAIN CONTROL MODULE (PCM) . . . . .	28	<b>DIAGNOSIS AND TESTING</b>	
MODES OF OPERATION . . . . .	29	VISUAL INSPECTION—3.9/5.2/5.9L ENGINES . . . . .	39
AUTOMATIC SHUTDOWN (ASD) RELAY		ASD AND FUEL PUMP RELAYS . . . . .	42
SENSE—PCM INPUT . . . . .	31	THROTTLE BODY MINIMUM AIR FLOW	
BATTERY VOLTAGE—PCM INPUT . . . . .	31	CHECK PROCEDURE . . . . .	43
BRAKE SWITCH—PCM INPUT . . . . .	31	<b>REMOVAL AND INSTALLATION</b>	
ENGINE COOLANT TEMPERATURE		AUTOMATIC SHUTDOWN (ASD) RELAY . . . . .	44
SENSOR—PCM INPUT . . . . .	32	FUEL PUMP RELAY . . . . .	44
FIVE VOLT SENSOR SUPPLIES—PRIMARY		OXYGEN SENSOR HEATER RELAYS . . . . .	45
AND SECONDARY . . . . .	32	THROTTLE BODY—3.9/5.2/5.9L ENGINES . . . . .	45
FUEL LEVEL SENSOR—PCM INPUT . . . . .	32	THROTTLE BODY—4.7L V-8 ENGINE . . . . .	45
IGNITION CIRCUIT SENSE—PCM INPUT . . . . .	32	THROTTLE POSITION SENSOR (TPS)—3.9/	
INTAKE MANIFOLD AIR TEMPERATURE		5.2/5.9L ENGINES . . . . .	46
SENSOR—PCM INPUT . . . . .	32	THROTTLE POSITION SENSOR (TPS)—4.7L	
MANIFOLD ABSOLUTE PRESSURE (MAP)		V-8 ENGINE . . . . .	46
SENSOR—PCM INPUT . . . . .	33	IDLE AIR CONTROL (IAC) MOTOR—3.9/5.2/	
OIL PRESSURE SENSOR—PCM INPUT . . . . .	34	5.9L ENGINES . . . . .	47
OXYGEN SENSOR (O <sub>2</sub> S)—PCM INPUT . . . . .	34	IDLE AIR CONTROL (IAC) MOTOR—4.7L V-8	
POWER GROUNDS . . . . .	35	ENGINE . . . . .	48
POWER STEERING PRESSURE SWITCH—		MANIFOLD ABSOLUTE PRESSURE (MAP)	
PCM INPUT . . . . .	35	SENSOR—3.9/5.2/5.9L ENGINES . . . . .	48
SENSOR RETURN—PCM INPUT . . . . .	36	MANIFOLD ABSOLUTE PRESSURE (MAP)	
SIGNAL GROUND—PCM INPUT . . . . .	36	SENSOR—4.7L V-8 ENGINE . . . . .	49
THROTTLE POSITION SENSOR (TPS)—PCM		POWERTRAIN CONTROL MODULE (PCM) . . . . .	49
INPUT . . . . .	36	OXYGEN SENSOR . . . . .	50
VEHICLE SPEED AND DISTANCE—PCM		AIR CLEANER ELEMENT (FILTER) . . . . .	50
INPUT . . . . .	36	ENGINE COOLANT TEMPERATURE	
AUTO SHUTDOWN (ASD) RELAY—PCM		SENSOR—3.9/5.2/5.9L ENGINES . . . . .	50
OUTPUT . . . . .	36	ENGINE COOLANT TEMPERATURE	
CCD BUS (+/-) CIRCUITS-PCM OUTPUTS . . . . .	37	SENSOR—4.7L V-8 ENGINE . . . . .	51
DATA LINK CONNECTOR—PCM INPUT AND		INTAKE MANIFOLD AIR TEMPERATURE	
OUTPUT . . . . .	37	SENSOR—3.9/5.2/5.9L ENGINES . . . . .	52
FUEL INJECTORS—PCM OUTPUT . . . . .	37	INTAKE MANIFOLD AIR TEMPERATURE	
FUEL PUMP RELAY-PCM OUTPUT . . . . .	37	SENSOR—4.7L V-8 ENGINE . . . . .	53
IDLE AIR CONTROL (IAC) MOTOR—PCM		POWER STEERING PRESSURE SWITCH . . . . .	54
OUTPUT . . . . .	37	<b>SPECIFICATIONS</b>	
OXYGEN SENSOR HEATER RELAYS—PCM		TORQUE CHART . . . . .	54
OUTPUT . . . . .	38	<b>SPECIAL TOOLS</b>	
RADIATOR COOLING FAN RELAY—PCM		FUEL SYSTEM . . . . .	54
OUTPUT . . . . .	38		

## DESCRIPTION AND OPERATION

### POWERTRAIN CONTROL MODULE (PCM)

#### DESCRIPTION

The Powertrain Control Module (PCM) (Fig. 1) is located in the engine compartment. The PCM is referred to as JTEC.



**Fig. 1 PCM Location**

- 1 - RIGHT FRONT FENDER
- 2 - PCM MOUNTING BOLTS (3)
- 3 - 32-WAY CONNECTORS (3)
- 4 - COVER
- 5 - POWERTRAIN CONTROL MODULE (PCM)

#### OPERATION

The PCM operates the fuel system. The PCM is a pre-programmed, triple microprocessor digital computer. It regulates ignition timing, air-fuel ratio, emission control devices, charging system, certain transmission features, speed control, air conditioning compressor clutch engagement and idle speed. The PCM can adapt its programming to meet changing operating conditions.

The PCM receives input signals from various switches and sensors. Based on these inputs, the PCM regulates various engine and vehicle operations through different system components. These components are referred to as Powertrain Control Module (PCM) Outputs. The sensors and switches that provide inputs to the PCM are considered Powertrain Control Module (PCM) Inputs.

The PCM adjusts ignition timing based upon inputs it receives from sensors that react to: engine rpm, manifold absolute pressure, engine coolant temperature, throttle position, transmission gear selec-

tion (automatic transmission), vehicle speed and the brake switch.

The PCM adjusts idle speed based on inputs it receives from sensors that react to: throttle position, vehicle speed, transmission gear selection, engine coolant temperature and from inputs it receives from the air conditioning clutch switch and brake switch.

Based on inputs that it receives, the PCM adjusts ignition coil dwell. The PCM also adjusts the generator charge rate through control of the generator field and provides speed control operation.

#### NOTE: PCM Inputs:

- A/C request (if equipped with factory A/C)
- A/C select (if equipped with factory A/C)
- Auto shutdown (ASD) sense
- Battery temperature
- Battery voltage
- Brake switch
- CCD bus (+) circuits
- CCD bus (-) circuits
- Camshaft position sensor signal
- Crankshaft position sensor
- Data link connection for DRB scan tool
- Engine coolant temperature sensor
- Fuel level
- Generator (battery voltage) output
- Ignition circuit sense (ignition switch in on/off/crank/run position)
- Intake manifold air temperature sensor
- Leak detection pump (switch) sense (if equipped)
- Manifold absolute pressure (MAP) sensor
- Oil pressure
- Output shaft speed sensor
- Overdrive/override switch
- Oxygen sensors
- Park/neutral switch (auto. trans. only)
- Power ground
- Sensor return
- Signal ground
- Speed control multiplexed single wire input
- Throttle position sensor
- Transmission governor pressure sensor
- Transmission temperature sensor
- Vehicle speed inputs from ABS or RWAL system

#### NOTE: PCM Outputs:

- A/C clutch relay
- Auto shutdown (ASD) relay
- CCD bus (+/-) circuits for: speedometer, voltmeter, fuel gauge, oil pressure gauge/lamp, engine temp. gauge and speed control warn. lamp
- Data link connection for DRB scan tool
- EGR valve control solenoid (if equipped)
- EVAP canister purge solenoid

## DESCRIPTION AND OPERATION (Continued)

- Five volt sensor supply (primary)
- Five volt sensor supply (secondary)
- Fuel injectors
- Fuel pump relay
- Generator field driver (-)
- Generator field driver (+)
- Generator lamp (if equipped)
- Idle air control (IAC) motor
- Ignition coil
- Leak detection pump (if equipped)
- Malfunction indicator lamp (Check engine lamp).

Driven through CCD circuits.

- Overdrive indicator lamp (if equipped)
- Speed control vacuum solenoid
- Speed control vent solenoid
- Tachometer (if equipped). Driven through CCD circuits.
- Transmission convertor clutch circuit
- Transmission 3-4 shift solenoid
- Transmission relay
- Transmission temperature lamp (if equipped)
- Transmission variable force solenoid

## MODES OF OPERATION

### OPERATION

As input signals to the Powertrain Control Module (PCM) change, the PCM adjusts its response to the output devices. For example, the PCM must calculate different injector pulse width and ignition timing for idle than it does for wide open throttle (WOT).

The PCM will operate in two different modes:

#### **Open Loop and Closed Loop.**

During Open Loop modes, the PCM receives input signals and responds only according to preset PCM programming. Input from the oxygen (O<sub>2</sub>S) sensors is not monitored during Open Loop modes.

During Closed Loop modes, the PCM will monitor the oxygen (O<sub>2</sub>S) sensors input. This input indicates to the PCM whether or not the calculated injector pulse width results in the ideal air-fuel ratio. This ratio is 14.7 parts air-to-1 part fuel. By monitoring the exhaust oxygen content through the O<sub>2</sub>S sensor, the PCM can fine tune the injector pulse width. This is done to achieve optimum fuel economy combined with low emission engine performance.

The fuel injection system has the following modes of operation:

- Ignition switch ON
- Engine start-up (crank)
- Engine warm-up
- Idle
- Cruise
- Acceleration
- Deceleration
- Wide open throttle (WOT)

- Ignition switch OFF

The ignition switch On, engine start-up (crank), engine warm-up, acceleration, deceleration and wide open throttle modes are Open Loop modes. The idle and cruise modes, (with the engine at operating temperature) are Closed Loop modes.

#### IGNITION SWITCH (KEY-ON) MODE

This is an Open Loop mode. When the fuel system is activated by the ignition switch, the following actions occur:

- The PCM pre-positions the idle air control (IAC) motor.
- The PCM determines atmospheric air pressure from the MAP sensor input to determine basic fuel strategy.
- The PCM monitors the engine coolant temperature sensor input. The PCM modifies fuel strategy based on this input.
- Intake manifold air temperature sensor input is monitored.
- Throttle position sensor (TPS) is monitored.
- The auto shutdown (ASD) relay is energized by the PCM for approximately three seconds.
- The fuel pump is energized through the fuel pump relay by the PCM. The fuel pump will operate for approximately three seconds unless the engine is operating or the starter motor is engaged.
- The O<sub>2</sub>S sensor heater element is energized via the ASD relay. The O<sub>2</sub>S sensor input is not used by the PCM to calibrate air-fuel ratio during this mode of operation.

#### ENGINE START-UP MODE

This is an Open Loop mode. The following actions occur when the starter motor is engaged.

The PCM receives inputs from:

- Battery voltage
- Engine coolant temperature sensor
- Crankshaft position sensor
- Intake manifold air temperature sensor
- Manifold absolute pressure (MAP) sensor
- Throttle position sensor (TPS)
- Starter motor relay
- Camshaft position sensor signal

The PCM monitors the crankshaft position sensor. If the PCM does not receive a crankshaft position sensor signal within 3 seconds of cranking the engine, it will shut down the fuel injection system.

The fuel pump is activated by the PCM through the fuel pump relay.

Voltage is applied to the fuel injectors with the ASD relay via the PCM. The PCM will then control the injection sequence and injector pulse width by turning the ground circuit to each individual injector on and off.

## DESCRIPTION AND OPERATION (Continued)

The PCM determines the proper ignition timing according to input received from the crankshaft position sensor.

## ENGINE WARM-UP MODE

This is an Open Loop mode. During engine warm-up, the PCM receives inputs from:

- Battery voltage
- Crankshaft position sensor
- Engine coolant temperature sensor
- Intake manifold air temperature sensor
- Manifold absolute pressure (MAP) sensor
- Throttle position sensor (TPS)
- Camshaft position sensor signal (in the distributor)
- Park/neutral switch (gear indicator signal—auto. trans. only)
- Air conditioning select signal (if equipped)
- Air conditioning request signal (if equipped)

Based on these inputs the following occurs:

- Voltage is applied to the fuel injectors with the ASD relay via the PCM. The PCM will then control the injection sequence and injector pulse width by turning the ground circuit to each individual injector on and off.
- The PCM adjusts engine idle speed through the idle air control (IAC) motor and adjusts ignition timing.
- The PCM operates the A/C compressor clutch through the clutch relay. This is done if A/C has been selected by the vehicle operator and requested by the A/C thermostat.
- When engine has reached operating temperature, the PCM will begin monitoring O<sub>2</sub>S sensor input. The system will then leave the warm-up mode and go into closed loop operation.

## IDLE MODE

When the engine is at operating temperature, this is a Closed Loop mode. At idle speed, the PCM receives inputs from:

- Air conditioning select signal (if equipped)
- Air conditioning request signal (if equipped)
- Battery voltage
- Crankshaft position sensor
- Engine coolant temperature sensor
- Intake manifold air temperature sensor
- Manifold absolute pressure (MAP) sensor
- Throttle position sensor (TPS)
- Camshaft position sensor signal (in the distributor)
- Battery voltage
- Park/neutral switch (gear indicator signal—auto. trans. only)
- Oxygen sensors

Based on these inputs, the following occurs:

- Voltage is applied to the fuel injectors with the ASD relay via the PCM. The PCM will then control injection sequence and injector pulse width by turning the ground circuit to each individual injector on and off.

- The PCM monitors the O<sub>2</sub>S sensor input and adjusts air-fuel ratio by varying injector pulse width. It also adjusts engine idle speed through the idle air control (IAC) motor.

- The PCM adjusts ignition timing by increasing and decreasing spark advance.

- The PCM operates the A/C compressor clutch through the clutch relay. This happens if A/C has been selected by the vehicle operator and requested by the A/C thermostat.

## CRUISE MODE

When the engine is at operating temperature, this is a Closed Loop mode. At cruising speed, the PCM receives inputs from:

- Air conditioning select signal (if equipped)
- Air conditioning request signal (if equipped)
- Battery voltage
- Engine coolant temperature sensor
- Crankshaft position sensor
- Intake manifold air temperature sensor
- Manifold absolute pressure (MAP) sensor
- Throttle position sensor (TPS)
- Camshaft position sensor signal (in the distributor)
- Park/neutral switch (gear indicator signal—auto. trans. only)

- Oxygen (O<sub>2</sub>S) sensors

Based on these inputs, the following occurs:

- Voltage is applied to the fuel injectors with the ASD relay via the PCM. The PCM will then adjust the injector pulse width by turning the ground circuit to each individual injector on and off.

- The PCM monitors the O<sub>2</sub>S sensor input and adjusts air-fuel ratio. It also adjusts engine idle speed through the idle air control (IAC) motor.

- The PCM adjusts ignition timing by turning the ground path to the coil on and off.

- The PCM operates the A/C compressor clutch through the clutch relay. This happens if A/C has been selected by the vehicle operator and requested by the A/C thermostat.

## ACCELERATION MODE

This is an Open Loop mode. The PCM recognizes an abrupt increase in throttle position or MAP pressure as a demand for increased engine output and vehicle acceleration. The PCM increases injector pulse width in response to increased throttle opening.

## DESCRIPTION AND OPERATION (Continued)

**DECELERATION MODE**

When the engine is at operating temperature, this is an Open Loop mode. During hard deceleration, the PCM receives the following inputs.

- Air conditioning select signal (if equipped)
- Air conditioning request signal (if equipped)
- Battery voltage
- Engine coolant temperature sensor
- Crankshaft position sensor
- Intake manifold air temperature sensor
- Manifold absolute pressure (MAP) sensor
- Throttle position sensor (TPS)
- Camshaft position sensor signal (in the distributor)
- Park/neutral switch (gear indicator signal—auto. trans. only)
- Vehicle speed sensor

If the vehicle is under hard deceleration with the proper rpm and closed throttle conditions, the PCM will ignore the oxygen sensor input signal. The PCM will enter a fuel cut-off strategy in which it will not supply a ground to the injectors. If a hard deceleration does not exist, the PCM will determine the proper injector pulse width and continue injection.

Based on the above inputs, the PCM will adjust engine idle speed through the idle air control (IAC) motor.

The PCM adjusts ignition timing by turning the ground path to the coil on and off.

**WIDE OPEN THROTTLE MODE**

This is an Open Loop mode. During wide open throttle operation, the PCM receives the following inputs.

- Battery voltage
- Crankshaft position sensor
- Engine coolant temperature sensor
- Intake manifold air temperature sensor
- Manifold absolute pressure (MAP) sensor
- Throttle position sensor (TPS)
- Camshaft position sensor signal (in the distributor)

During wide open throttle conditions, the following occurs:

- Voltage is applied to the fuel injectors with the ASD relay via the PCM. The PCM will then control the injection sequence and injector pulse width by turning the ground circuit to each individual injector on and off. The PCM ignores the oxygen sensor input signal and provides a predetermined amount of additional fuel. This is done by adjusting injector pulse width.

- The PCM adjusts ignition timing by turning the ground path to the coil on and off.

**IGNITION SWITCH OFF MODE**

When ignition switch is turned to OFF position, the PCM stops operating the injectors, ignition coil, ASD relay and fuel pump relay.

**AUTOMATIC SHUTDOWN (ASD) RELAY SENSE—PCM INPUT****DESCRIPTION**

The ASD relay is located in the Power Distribution Center (PDC). The PDC is located in the engine compartment. Refer to label on PDC cover for relay location.

**OPERATION**

A 12 volt signal at this input indicates to the PCM that the ASD has been activated. The relay is used to connect the oxygen sensor heater element, ignition coil and fuel injectors to 12 volt + power supply.

This input is used only to sense that the ASD relay is energized. If the powertrain control module (PCM) does not see 12 volts at this input when the ASD should be activated, it will set a diagnostic trouble code (DTC).

**BATTERY VOLTAGE—PCM INPUT****OPERATION**

The battery voltage input provides power to the Powertrain Control Module (PCM). It also informs the PCM what voltage level is supplied to the ignition coil and fuel injectors.

If battery voltage is low, the PCM will increase injector pulse width (period of time that the injector is energized). This is done to compensate for the reduced flow through injector caused by the lowered voltage.

**BRAKE SWITCH—PCM INPUT****OPERATION**

When the brake light switch is activated, the Powertrain Control Module (PCM) receives an input indicating that the brakes are being applied. After receiving this input, the PCM maintains idle speed to a scheduled rpm through control of the Idle Air Control (IAC) motor. The brake switch input is also used to disable vent and vacuum solenoid output signals to the speed control servo.

## DESCRIPTION AND OPERATION (Continued)

**ENGINE COOLANT TEMPERATURE SENSOR—PCM INPUT****DESCRIPTION**

The Engine Coolant Temperature (ECT) sensor is used to sense engine coolant temperature. The sensor protrudes into an engine water jacket.

The ECT sensor is a two-wire Negative Thermal Coefficient (NTC) sensor. Meaning, as engine coolant temperature increases, resistance (voltage) in the sensor decreases. As temperature decreases, resistance (voltage) in the sensor increases.

**OPERATION**

At key-on, the Powertrain Control Module (PCM) sends out a regulated 5 volt signal to the ECT sensor. The PCM then monitors the signal as it passes through the ECT sensor to the sensor ground (sensor return).

When the engine is cold, the PCM will operate in Open Loop cycle. It will demand slightly richer air-fuel mixtures and higher idle speeds. This is done until normal operating temperatures are reached.

The PCM uses inputs from the ECT sensor for the following calculations:

- for engine coolant temperature gauge operation through CCD or PCI (J1850) communications
- Injector pulse-width
- Spark-advance curves
- ASD relay shut-down times
- Idle Air Control (IAC) motor key-on steps
- Pulse-width prime-shot during cranking
- O<sub>2</sub> sensor closed loop times
- Purge solenoid on/off times
- EGR solenoid on/off times (if equipped)
- Leak Detection Pump operation (if equipped)
- Radiator fan relay on/off times (if equipped)
- Target idle speed

**FIVE VOLT SENSOR SUPPLIES—PRIMARY AND SECONDARY****DESCRIPTION**

Two different Powertrain Control Module (PCM) five volt supply circuits are used; primary and secondary.

**OPERATION**

These 2 circuits will:

- supply the required 5 volt power source to the Crankshaft Position (CKP) sensor.
- supply the required 5 volt power source to the Camshaft Position (CMP) sensor.
- supply a reference voltage for the Manifold Absolute Pressure (MAP) sensor.

- supply a reference voltage for the Throttle Position Sensor (TPS) sensor.
- supply the required 5 volt power source to the oil pressure sensor.
- supply the required 5 volt power source for the Vehicle Speed Sensor (VSS) (if equipped).
- supply the 5 volt power source to the transmission pressure sensor (if equipped with an RE automatic transmission).

**FUEL LEVEL SENSOR—PCM INPUT****DESCRIPTION**

The fuel level sensor (fuel gauge sending unit) is located on the fuel pump module.

**OPERATION**

Refer to Fuel Gauge Sending Unit in the Fuel Delivery section for information.

**IGNITION CIRCUIT SENSE—PCM INPUT****DESCRIPTION**

This circuit ties the ignition switch to the Powertrain Control Module (PCM).

**OPERATION**

The ignition circuit sense input tells the PCM the ignition switch has energized the ignition circuit.

Battery voltage is supplied to the PCM through the ignition switch when the ignition is in the RUN or START position. This is referred to as the "ignition sense" circuit and is used to "wake up" the PCM. Voltage on the ignition input can be as low as 6 volts and the PCM will still function. Voltage is supplied to this circuit to power the PCM's 5 volt primary and 5 volt secondary circuits. This allows the PCM to perform fuel, ignition and emissions control functions.

**INTAKE MANIFOLD AIR TEMPERATURE SENSOR—PCM INPUT****DESCRIPTION**

The 2-wire Intake Manifold Air Temperature (IAT) sensor is installed in the intake manifold with the sensor element extending into the air stream.

The IAT sensor is a two-wire Negative Thermal Coefficient (NTC) sensor. Meaning, as intake manifold temperature increases, resistance (voltage) in the sensor decreases. As temperature decreases, resistance (voltage) in the sensor increases.

**OPERATION**

The IAT sensor provides an input voltage to the Powertrain Control Module (PCM) indicating the density of the air entering the intake manifold based



## DESCRIPTION AND OPERATION (Continued)

upon intake manifold temperature. At key-on, a 5-volt power circuit is supplied to the sensor from the PCM. The sensor is grounded at the PCM through a low-noise, sensor-return circuit.

The PCM uses this input to calculate the following:

- Injector pulse-width
- Adjustment of spark timing (to help prevent spark knock with high intake manifold air-charge temperatures)

The resistance values of the IAT sensor is the same as for the Engine Coolant Temperature (ECT) sensor.

## MANIFOLD ABSOLUTE PRESSURE (MAP) SENSOR—PCM INPUT

### DESCRIPTION

The Manifold Absolute Pressure (MAP) sensor is attached to the side of the engine throttle body with 2 screws. The sensor is connected to the throttle body with a rubber L-shaped fitting.

### OPERATION

The MAP sensor is used as an input to the Powertrain Control Module (PCM). It contains a silicon based sensing unit to provide data on the manifold vacuum that draws the air/fuel mixture into the combustion chamber. The PCM requires this information to determine injector pulse width and spark advance. When manifold absolute pressure (MAP) equals Barometric pressure, the pulse width will be at maximum.

A 5 volt reference is supplied from the PCM and returns a voltage signal to the PCM that reflects manifold pressure. The zero pressure reading is 0.5V and full scale is 4.5V. For a pressure swing of 0–15 psi, the voltage changes 4.0V. To operate the sensor, it is supplied a regulated 4.8 to 5.1 volts. Ground is provided through the low-noise, sensor return circuit at the PCM.

The MAP sensor input is the number one contributor to fuel injector pulse width. The most important function of the MAP sensor is to determine barometric pressure. The PCM needs to know if the vehicle is at sea level or at a higher altitude, because the air density changes with altitude. It will also help to correct for varying barometric pressure. Barometric pressure and altitude have a direct inverse correlation; as altitude goes up, barometric goes down. At key-on, the PCM powers up and looks at MAP voltage, and based upon the voltage it sees, it knows the current barometric pressure (relative to altitude). Once the engine starts, the PCM looks at the voltage again, continuously every 12 milliseconds, and compares the current voltage to what it was at key-on. The difference between current voltage and what it was at key-on, is manifold vacuum.

During key-on (engine not running) the sensor reads (updates) barometric pressure. A normal range can be obtained by monitoring a known good sensor.

As the altitude increases, the air becomes thinner (less oxygen). If a vehicle is started and driven to a very different altitude than where it was at key-on, the barometric pressure needs to be updated. Any time the PCM sees Wide Open Throttle (WOT), based upon Throttle Position Sensor (TPS) angle and RPM, it will update barometric pressure in the MAP memory cell. With periodic updates, the PCM can make its calculations more effectively.

The PCM uses the MAP sensor input to aid in calculating the following:

- Manifold pressure
- Barometric pressure
- Engine load
- Injector pulse-width
- Spark-advance programs
- Shift-point strategies (certain automatic transmissions only)
- Idle speed
- Decel fuel shutoff

The MAP sensor signal is provided from a single piezoresistive element located in the center of a diaphragm. The element and diaphragm are both made of silicone. As manifold pressure changes, the diaphragm moves causing the element to deflect, which stresses the silicone. When silicone is exposed to stress, its resistance changes. As manifold vacuum increases, the MAP sensor input voltage decreases proportionally. The sensor also contains electronics that condition the signal and provide temperature compensation.

The PCM recognizes a decrease in manifold pressure by monitoring a decrease in voltage from the reading stored in the barometric pressure memory cell. The MAP sensor is a linear sensor; meaning as pressure changes, voltage changes proportionately. The range of voltage output from the sensor is usually between 4.6 volts at sea level to as low as 0.3 volts at 26 in. of Hg. Barometric pressure is the pressure exerted by the atmosphere upon an object. At sea level on a standard day, no storm, barometric pressure is approximately 29.92 in Hg. For every 100 feet of altitude, barometric pressure drops 1.0 in. Hg. If a storm goes through it can change barometric pressure from what should be present for that altitude. You should know what the average pressure and corresponding barometric pressure is for your area.

## DESCRIPTION AND OPERATION (Continued)

**OIL PRESSURE SENSOR—PCM INPUT****DESCRIPTION**

The 2-wire, electrical/mechanical engine oil pressure sensor (sending unit) is located in an engine oil pressure gallery.

**OPERATION**

The oil pressure sensor uses two circuits. They are:

- A signal to the PCM relating to engine oil pressure
- A sensor ground through the PCM's sensor return

The oil pressure sensor returns a voltage signal back to the PCM relating to engine oil pressure. This signal is then transferred (bussed) to the instrument panel on a CCD bus circuit to operate the oil pressure gauge and the check gauges lamp. Ground for the sensor is provided by the PCM through a low-noise sensor return.

**OXYGEN SENSOR (O2S)—PCM INPUT****DESCRIPTION**

The Oxygen Sensors (O2S) are attached to, and protrude into the vehicle exhaust system. Depending on the emission package, the vehicle may use a total of either 2 or 4 sensors.

**Non-California Engines:** On certain non-California (Federal) emissions packages, 2 sensors are used: upstream (referred to as 1/1) and downstream (referred to as 1/2). With this emission package, the upstream sensor (1/1) is located just before the main catalytic convertor. The downstream sensor (1/2) is located just after the main catalytic convertor.

**California Engines:** On certain California emissions packages, 4 sensors are used: 2 upstream (referred to as 1/1 and 2/1) and 2 downstream (referred to as 1/2 and 2/2). With this emission package, the right upstream sensor (2/1) is located in the right exhaust downpipe just before the mini-catalytic convertor. The left upstream sensor (1/1) is located in the left exhaust downpipe just before the mini-catalytic convertor. The right downstream sensor (2/2) is located in the right exhaust downpipe just after the mini-catalytic convertor, and before the main catalytic convertor. The left downstream sensor (1/2) is located in the left exhaust downpipe just after the mini-catalytic convertor, and before the main catalytic convertor.

**OPERATION**

An O2 sensor is a galvanic battery that provides the PCM with a voltage signal (0-1 volt) inversely proportional to the amount of oxygen in the exhaust. In other words, if the oxygen content is low, the volt-

age output is high; if the oxygen content is high the output voltage is low. The PCM uses this information to adjust injector pulse-width to achieve the 14.7-to-1 air/fuel ratio necessary for proper engine operation and to control emissions.

The O2 sensor must have a source of oxygen from outside of the exhaust stream for comparison. Current O2 sensors receive their fresh oxygen (outside air) supply through the wire harness. This is why it is important to never solder an O2 sensor connector, or pack the connector with grease.

Four wires (circuits) are used on each O2 sensor: a 12-volt feed circuit for the sensor heating element; a ground circuit for the heater element; a low-noise sensor return circuit to the PCM, and an input circuit from the sensor back to the PCM to detect sensor operation.

**Oxygen Sensor Heaters/Heater Relays:** Depending on the emissions package, the heating elements within the sensors will be supplied voltage from either the ASD relay, or 2 separate oxygen sensor relays. Refer to Wiring Diagrams to determine which relays are used.

The O2 sensor uses a Positive Thermal Co-efficient (PTC) heater element. As temperature increases, resistance increases. At ambient temperatures around 70°F, the resistance of the heating element is approximately 4.5 ohms on 5.2 and 5.9L engines, and approximately 13.5 ohms on the 4.7L engine. As the sensor's temperature increases, resistance in the heater element increases. This allows the heater to maintain the optimum operating temperature of approximately 930°-1100°F (500°-600° C). Although the sensors operate the same, there are physical differences, due to the environment that they operate in, that keep them from being interchangeable.

Maintaining correct sensor temperature at all times allows the system to enter into closed loop operation sooner. Also, it allows the system to remain in closed loop operation during periods of extended idle.

In Closed Loop operation, the PCM monitors certain O2 sensor input(s) along with other inputs, and adjusts the injector pulse width accordingly. During Open Loop operation, the PCM ignores the O2 sensor input. The PCM adjusts injector pulse width based on preprogrammed (fixed) values and inputs from other sensors.

**Upstream Sensor (Certain Non-California Emissions):** The upstream sensor (1/1) provides an input voltage to the PCM. The input tells the PCM the oxygen content of the exhaust gas. The PCM uses this information to fine tune fuel delivery to maintain the correct oxygen content at the downstream oxygen sensor. The PCM will change the air/fuel ratio until the upstream sensor inputs a voltage that

## DESCRIPTION AND OPERATION (Continued)

the PCM has determined will make the downstream sensor output (oxygen content) correct.

The upstream oxygen sensor also provides an input to determine catalytic convertor efficiency.

**Downstream Sensor (Certain Non-California Emissions):** The downstream oxygen sensor (1/2) is also used to determine the correct air-fuel ratio. As the oxygen content changes at the downstream sensor, the PCM calculates how much air-fuel ratio change is required. The PCM then looks at the upstream oxygen sensor voltage and changes fuel delivery until the upstream sensor voltage changes enough to correct the downstream sensor voltage (oxygen content).

The downstream oxygen sensor also provides an input to determine catalytic convertor efficiency.

**Upstream Sensors (Certain California Emissions):** Two upstream sensors are used (1/1 and 2/1). The 1/1 sensor is the first sensor to receive exhaust gases from the #1 cylinder. They provide an input voltage to the PCM. The input tells the PCM the oxygen content of the exhaust gas. The PCM uses this information to fine tune fuel delivery to maintain the correct oxygen content at the downstream oxygen sensors. The PCM will change the air/fuel ratio until the upstream sensors input a voltage that the PCM has determined will make the downstream sensors output (oxygen content) correct.

The upstream oxygen sensors also provide an input to determine mini-catalyst efficiency. Main catalytic convertor efficiency is not calculated with this package.

**Downstream Sensors (Certain California Emissions):** Two downstream sensors are used (1/2 and 2/2). The downstream sensors are used to determine the correct air-fuel ratio. As the oxygen content changes at the downstream sensor, the PCM calculates how much air-fuel ratio change is required. The PCM then looks at the upstream oxygen sensor voltage, and changes fuel delivery until the upstream sensor voltage changes enough to correct the downstream sensor voltage (oxygen content).

The downstream oxygen sensors also provide an input to determine mini-catalyst efficiency. Main catalytic convertor efficiency is not calculated with this package.

Engines equipped with either a downstream sensor(s), or a post-catalytic sensor, will monitor catalytic convertor efficiency. If efficiency is below emission standards, the Malfunction Indicator Lamp (MIL) will be illuminated and a Diagnostic Trouble Code (DTC) will be set. Refer to Monitored Systems in Emission Control Systems for additional information.

## POWER GROUNDS

## OPERATION

The Powertrain Control Module (PCM) has 2 main grounds. Both of these grounds are referred to as power grounds. All of the high-current, noisy, electrical devices are connected to these grounds as well as all of the sensor returns. Sensor return is a low-noise, low-current, dedicated ground.

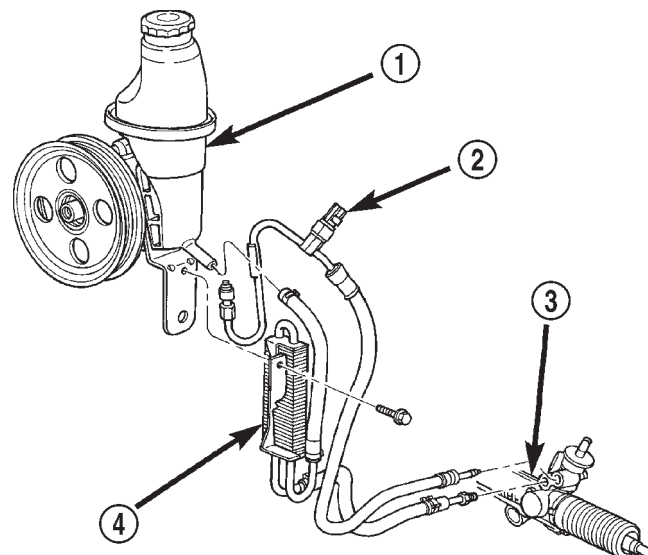
The power ground is used to control ground circuits for the following PCM loads:

- Generator field winding
- Fuel injectors
- Ignition coil(s)
- Certain relays/solenoids
- Certain sensors

## POWER STEERING PRESSURE SWITCH—PCM INPUT

## DESCRIPTION

A pressure sensing switch (Fig. 2) is included in the power steering system (mounted on the high-pressure line). This switch will be used only on vehicles equipped with a 4.7L V-8 engine and power steering.



80bfe152

**Fig. 2 Power Steering Pump Pressure Switch—4.7L V-8 Engine**

- 1 - HYDRAULIC PUMP
- 2 - POWER STEERING PRESSURE SWITCH
- 3 - RACK AND PINION GEAR
- 4 - OIL COOLER

## DESCRIPTION AND OPERATION (Continued)

**OPERATION**

The power steering pressure switch provides an input to the Powertrain Control Module (PCM). This input is provided during periods of high pump load and low engine rpm; such as during parking maneuvers. The PCM will then increase the idle speed through the Idle Air Control (IAC) motor. This is done to prevent the engine from stalling under the increased load.

When steering pump pressure exceeds  $3275 \text{ kPa} \pm 690 \text{ kPa}$  ( $475 \text{ psi} \pm 100 \text{ psi}$ ), the normally closed switch will open and the PCM will increase the engine idle speed. This will prevent the engine from stalling.

When pump pressure drops to approximately  $1379 \text{ kPa}$  ( $200 \text{ psi}$ ), the switch circuit will re-close and engine idle speed will return to its previous setting.

**SENSOR RETURN—PCM INPUT****OPERATION**

The Sensor Return circuits are internal to the Powertrain Control Module (PCM).

Sensor Return provides a low-noise ground reference for all engine control system sensors. Refer to Power Grounds for more information.

**SIGNAL GROUND—PCM INPUT****OPERATION**

Signal ground provides a low noise ground to the data link connector.

**THROTTLE POSITION SENSOR (TPS)—PCM INPUT****DESCRIPTION**

The 3-wire Throttle Position Sensor (TPS) is mounted on the throttle body and is connected to the throttle blade.

**OPERATION**

The TPS is a 3-wire variable resistor that provides the Powertrain Control Module (PCM) with an input signal (voltage) that represents the throttle blade position of the throttle body. The sensor is connected to the throttle blade shaft. As the position of the throttle blade changes, the resistance (output voltage) of the TPS changes.

The PCM supplies approximately 5 volts to the TPS. The TPS output voltage (input signal to the PCM) represents the throttle blade position. The PCM receives an input signal voltage from the TPS. This will vary in an approximate range of from .26 volts at minimum throttle opening (idle), to 4.49 volts at wide open throttle. Along with inputs from other

sensors, the PCM uses the TPS input to determine current engine operating conditions. In response to engine operating conditions, the PCM will adjust fuel injector pulse width and ignition timing.

The PCM needs to identify the actions and position of the throttle blade at all times. This information is needed to assist in performing the following calculations:

- Ignition timing advance
- Fuel injection pulse-width
- Idle (learned value or minimum TPS)
- Off-idle (0.06 volt)
- Wide Open Throttle (WOT) open loop (2.608 volts above learned idle voltage)
- Deceleration fuel lean out
- Fuel cutoff during cranking at WOT (2.608 volts above learned idle voltage)
- A/C WOT cutoff (certain automatic transmissions only)

**VEHICLE SPEED AND DISTANCE—PCM INPUT****OPERATION**

Vehicle speed and distance covered are measured by the Rear Wheel Speed Sensor. The sensor is mounted to the rear axle. A signal is sent from this sensor to the Controller Antilock Brake (CAB) computer. A signal is then sent from the CAB to the Powertrain Control Module (PCM) to determine vehicle speed and distance covered. The PCM will then determine strategies for fuel system and speed control system operation.

Refer to Odometer and Trip Odometer in Group 8E, Instrument Panel for additional information.

**AUTO SHUTDOWN (ASD) RELAY—PCM OUTPUT****DESCRIPTION**

The 5-pin, 12-volt, Automatic Shutdown (ASD) relay is located in the Power Distribution Center (PDC). Refer to label on PDC cover for relay location.

**OPERATION**

The ASD relay supplies battery voltage (12+ volts) to the fuel injectors and ignition coil(s). With certain emissions packages it also supplies 12-volts to the oxygen sensor heating elements.

The ground circuit for the coil within the ASD relay is controlled by the Powertrain Control Module (PCM). The PCM operates the ASD relay by switching its ground circuit on and off.

The ASD relay will be shut-down, meaning the 12-volt power supply to the ASD relay will be de-activated by the PCM if:

**DESCRIPTION AND OPERATION (Continued)**

- the ignition key is left in the ON position. This is if the engine has not been running for approximately 1.8 seconds.

- there is a crankshaft position sensor signal to the PCM that is lower than pre-determined values.

The PCM will sense if or when the ASD relay has been activated through a “sense circuit”. Refer to Automatic Shut-Down (ASD) Relay Sense-PCM Input for additional information.

**CCD BUS (+/-) CIRCUITS-PCM OUTPUTS****OPERATION**

The Powertrain Control Module (PCM) sends certain output signals through the CCD bus circuits. These signals are used to control certain instrument panel located items and to determine certain identification numbers.

Refer to Group 8E, Instrument Panel and Gauges for additional information.

**DATA LINK CONNECTOR—PCM INPUT AND OUTPUT****DESCRIPTION**

The data link connector is located at the lower edge of the instrument panel near the steering column.

**OPERATION**

The 16-way data link connector (diagnostic scan tool connector) links the Diagnostic Readout Box (DRB) scan tool or the Mopar Diagnostic System (MDS) with the Powertrain Control Module (PCM).

**FUEL INJECTORS—PCM OUTPUT****DESCRIPTION**

The fuel injectors are connected to the engine with the fuel injector rail.

**OPERATION**

The nozzle ends of the injectors are positioned into openings in the intake manifold just above the intake valve ports of the cylinder head. The engine wiring harness connector for each fuel injector is equipped with an attached numerical tag (INJ 1, INJ 2 etc.). This is used to identify each fuel injector with its respective cylinder number.

The injectors are energized individually in a sequential order by the Powertrain Control Module (PCM). The PCM will adjust injector pulse width by switching the ground path to each individual injector on and off. Injector pulse width is the period of time that the injector is energized. The PCM will adjust

injector pulse width based on various inputs it receives.

Battery voltage (12 volts +) is supplied to the injectors through the ASD relay. The ASD relay will shut-down the 12 volt power source to the fuel injectors if the PCM senses the ignition is on, but the engine is not running. This occurs after the engine has not been running for approximately 1.8 seconds.

The PCM determines injector on-time (pulse width) based on various inputs.

**FUEL PUMP RELAY-PCM OUTPUT****DESCRIPTION**

The 5-pin, 12-volt, fuel pump relay is located in the Power Distribution Center (PDC). Refer to the label on the PDC cover for relay location.

**OPERATION**

The Powertrain Control Module (PCM) energizes the electric fuel pump through the fuel pump relay. The fuel pump relay is energized by first applying battery voltage to it when the ignition key is turned ON, and then applying a ground signal to the relay from the PCM.

Whenever the ignition key is turned ON, the electric fuel pump will operate. But, the PCM will shut-down the ground circuit to the fuel pump relay in approximately 1–3 seconds unless the engine is operating or the starter motor is engaged.

**IDLE AIR CONTROL (IAC) MOTOR—PCM OUTPUT****DESCRIPTION**

The IAC stepper motor is mounted to the throttle body, and regulates the amount of air bypassing the control of the throttle plate. As engine loads and ambient temperatures change, engine rpm changes. A pintle on the IAC stepper motor protrudes into a passage in the throttle body, controlling air flow through the passage. The IAC is controlled by the Powertrain Control Module (PCM) to maintain the target engine idle speed.

**OPERATION**

At idle, engine speed can be increased by retracting the IAC motor pintle and allowing more air to pass through the port, or it can be decreased by restricting the passage with the pintle and diminishing the amount of air bypassing the throttle plate.

The IAC is called a stepper motor because it is moved (rotated) in steps, or increments. Opening the IAC opens an air passage around the throttle blade which increases RPM.

## DESCRIPTION AND OPERATION (Continued)

The PCM uses the IAC motor to control idle speed (along with timing) and to reach a desired MAP during decel (keep engine from stalling).

The IAC motor has 4 wires with 4 circuits. Two of the wires are for 12 volts and ground to supply electrical current to the motor windings to operate the stepper motor in one direction. The other 2 wires are also for 12 volts and ground to supply electrical current to operate the stepper motor in the opposite direction.

To make the IAC go in the opposite direction, the PCM just reverses polarity on both windings. If only 1 wire is open, the IAC can only be moved 1 step (increment) in either direction. To keep the IAC motor in position when no movement is needed, the PCM will energize both windings at the same time. This locks the IAC motor in place.

In the IAC motor system, the PCM will count every step that the motor is moved. This allows the PCM to determine the motor pintle position. If the memory is cleared, the PCM no longer knows the position of the pintle. So at the first key ON, the PCM drives the IAC motor closed, regardless of where it was before. This zeros the counter. From this point the PCM will back out the IAC motor and keep track of its position again.

When engine rpm is above idle speed, the IAC is used for the following:

- Off-idle dashpot (throttle blade will close quickly but idle speed will not stop quickly)
- Deceleration air flow control
- A/C compressor load control (also opens the passage slightly before the compressor is engaged so that the engine rpm does not dip down when the compressor engages)
- Power steering load control

The PCM can control polarity of the circuit to control direction of the stepper motor.

**IAC Stepper Motor Program:** The PCM is also equipped with a memory program that records the number of steps the IAC stepper motor most recently advanced to during a certain set of parameters. For example: The PCM was attempting to maintain a 1000 rpm target during a cold start-up cycle. The last recorded number of steps for that may have been 125. That value would be recorded in the memory cell so that the next time the PCM recognizes the identical conditions, the PCM recalls that 125 steps were required to maintain the target. This program allows for greater customer satisfaction due to greater control of engine idle.

Another function of the memory program, which occurs when the power steering switch (if equipped), or the A/C request circuit, requires that the IAC stepper motor control engine rpm, is the recording of the last targeted steps into the memory cell. The PCM

can anticipate A/C compressor loads. This is accomplished by delaying compressor operation for approximately 0.5 seconds until the PCM moves the IAC stepper motor to the recorded steps that were loaded into the memory cell. Using this program helps eliminate idle-quality changes as loads change. Finally, the PCM incorporates a "No-Load" engine speed limiter of approximately 1800 - 2000 rpm, when it recognizes that the TPS is indicating an idle signal and IAC motor cannot maintain engine idle.

A (factory adjusted) set screw is used to mechanically limit the position of the throttle body throttle plate. **Never attempt to adjust the engine idle speed using this screw.** All idle speed functions are controlled by the IAC motor through the PCM.

## OXYGEN SENSOR HEATER RELAYS—PCM OUTPUT

### DESCRIPTION

The 2 oxygen (O<sub>2</sub>) sensor heater relays (upstream and downstream) are located in the Powertrain Distribution Center (PDC).

### OPERATION

Engines equipped with the California (NAE) Emissions Package use **four O<sub>2</sub> sensors**.

Two of the four sensor heater elements (upstream sensors 1/1 and 2/1) are controlled by the upstream heater relay through output signals from the Powertrain Control Module (PCM).

The other two heater elements (downstream sensors 1/2 and 2/2) are controlled by the downstream heater relay through output signals from the PCM.

To avoid a large simultaneous current surge, power is delayed to the 2 downstream heater elements by the PCM for approximately 2 seconds.

## RADIATOR COOLING FAN RELAY—PCM OUTPUT

### DESCRIPTION

The radiator cooling fan relay is a 5-pin, solenoid type, mini-relay. It is located in the Power Distribution Center (PDC). Refer to label on PDC cover for relay location.

### OPERATION

The electric radiator cooling fan is controlled by the Powertrain Control Module (PCM) through the radiator cooling fan relay. The PCM will activate the relay after receiving inputs from the engine coolant temperature sensor and/or an air conditioning on/off signal. **Not Equipped With A/C:** The relay is energized when coolant temperature is above approximately 103°C (217°F). It will then de-energize when

DESCRIPTION AND OPERATION (Continued)

coolant temperature drops to approximately 98°C (208°F). Refer to Cooling Systems for additional information. **Equipped With A/C:** In addition to using coolant temperatures to control cooling fan operation, the cooling fan will also be engaged when the air conditioning system has been activated. Refer to Heating and Air Conditioning for additional information.

**THROTTLE BODY**

**DESCRIPTION**

The throttle body is located on the intake manifold. Fuel does not enter the intake manifold through the throttle body. Fuel is sprayed into the manifold by the fuel injectors.

**OPERATION**

Filtered air from the air cleaner enters the intake manifold through the throttle body. The throttle body contains an air control passage controlled by an Idle Air Control (IAC) motor. The air control passage is used to supply air for idle conditions. A throttle valve (plate) is used to supply air for above idle conditions.

Certain sensors are attached to the throttle body. The accelerator pedal cable, speed control cable and transmission control cable (when equipped) are connected to the throttle body linkage arm.

A (factory adjusted) set screw is used to mechanically limit the position of the throttle body throttle plate. **Never attempt to adjust the engine idle speed using this screw.** All idle speed functions are controlled by the PCM.

**DIAGNOSIS AND TESTING**

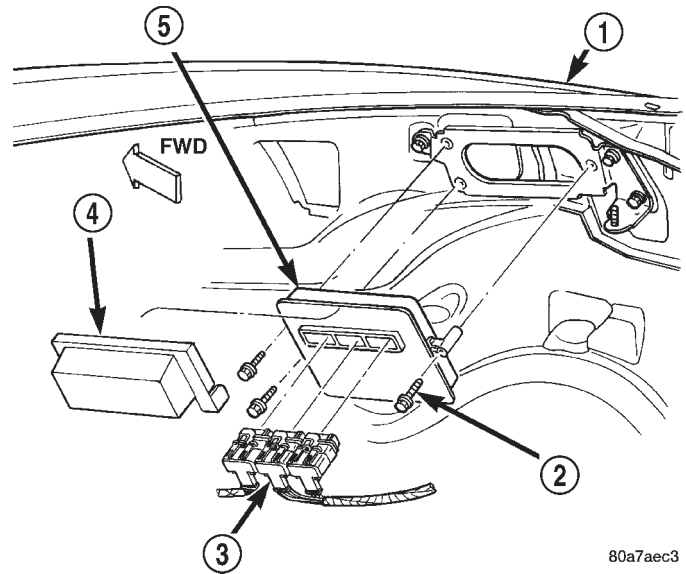
**VISUAL INSPECTION—3.9/5.2/5.9L ENGINES**

A visual inspection for loose, disconnected or incorrectly routed wires and hoses should be made. This should be done before attempting to diagnose or service the fuel injection system. A visual check will help spot these faults and save unnecessary test and diagnostic time. A thorough visual inspection will include the following checks:

(1) Verify three 32-way electrical connectors are fully inserted into connector of powertrain control module (PCM) (Fig. 3).

(2) Inspect battery cable connections. Be sure they are clean and tight.

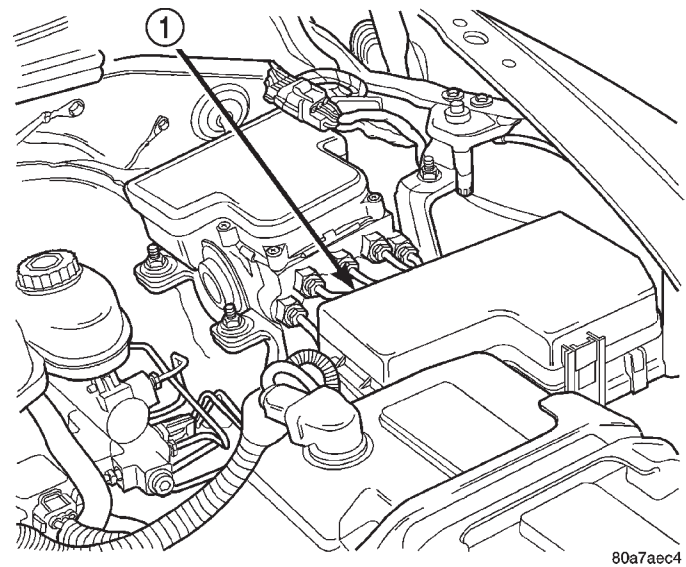
(3) Inspect fuel pump relay and air conditioning compressor clutch relay (if equipped). Inspect ASD relay connections. Inspect starter motor relay connections. Inspect relays for signs of physical damage and corrosion. The relays are located in Power Distribu-



**Fig. 3 Powertrain Control Module (PCM)**

- 1 - RIGHT FRONT FENDER
- 2 - PCM MOUNTING BOLTS (3)
- 3 - 32-WAY CONNECTORS (3)
- 4 - COVER
- 5 - POWERTRAIN CONTROL MODULE (PCM)

tion Center (PDC) (Fig. 4). Refer to label on PDC cover for relay location.



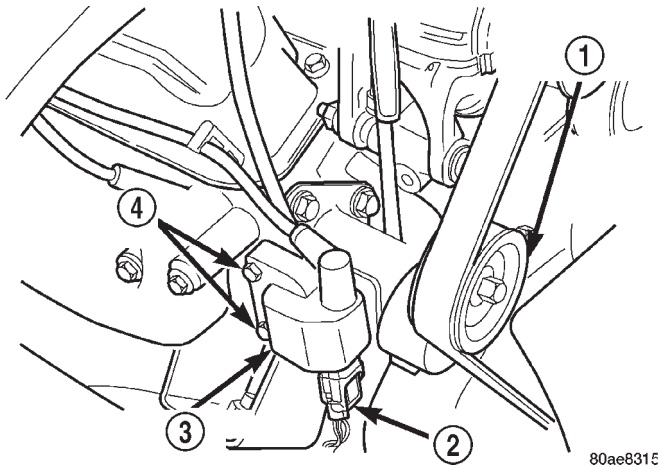
**Fig. 4 Power Distribution Center (PDC)**

- 1 - POWER DISTRIBUTION CENTER (PDC)

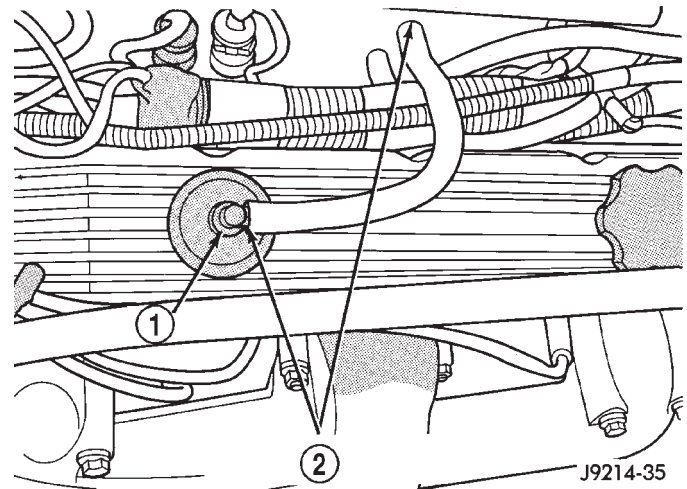
(4) Inspect ignition coil connections. Verify coil secondary cable is firmly connected to coil (Fig. 5).

(5) Verify distributor cap is correctly attached to distributor. Be sure spark plug cables are firmly connected to the distributor cap and the spark plugs are in their correct firing order. Be sure coil cable is

## DIAGNOSIS AND TESTING (Continued)

**Fig. 5 Ignition Coil**

- 1 - ACCESSORY DRIVE BELT TENSIONER
- 2 - COIL CONNECTOR
- 3 - IGNITION COIL
- 4 - COIL MOUNTING BOLTS

**Fig. 6 PCV Valve Hose Connections**

- 1 - PCV VALVE
- 2 - PCV VALVE HOSE CONNECTIONS

firmly connected to distributor cap and coil. Be sure camshaft position sensor wire connector (at the distributor) is firmly connected to harness connector. Inspect spark plug condition. Refer to Group 8D, Ignition. Connect vehicle to an oscilloscope and inspect spark events for fouled or damaged spark plugs or cables.

(6) Verify generator output wire, generator connector and ground wire are firmly connected to generator.

(7) Inspect system body grounds for loose or dirty connections. Refer to Group 8, Wiring for ground locations.

(8) Verify positive crankcase ventilation (PCV) valve operation. Refer to Group 25, Emission Control System for additional information. Verify PCV valve hose is firmly connected to PCV valve and manifold (Fig. 6).

(9) Inspect fuel tube quick-connect fitting-to-fuel rail connections.

(10) Verify hose connections to all ports of vacuum fittings on intake manifold are tight and not leaking.

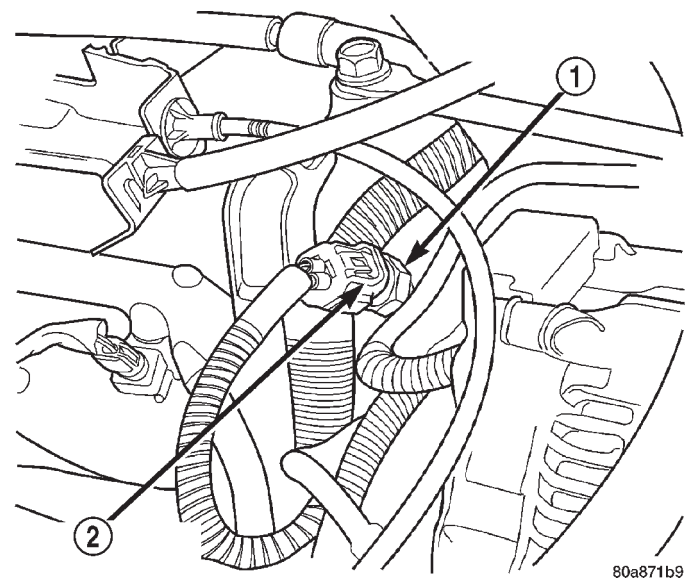
(11) Inspect accelerator cable, transmission throttle cable (if equipped) and cruise control cable connections (if equipped). Check their connections to throttle arm of throttle body for any binding or restrictions.

(12) If equipped with vacuum brake booster, verify vacuum booster hose is firmly connected to fitting on intake manifold. Also check connection to brake vacuum booster.

(13) Inspect air cleaner inlet and air cleaner element for dirt or restrictions.

(14) Inspect radiator grille area, radiator fins and air conditioning condenser for restrictions.

(15) Verify intake manifold air temperature sensor wire connector is firmly connected to harness connector (Fig. 7).

**Fig. 7 Intake Manifold Air Temperature Sensor—Typical**

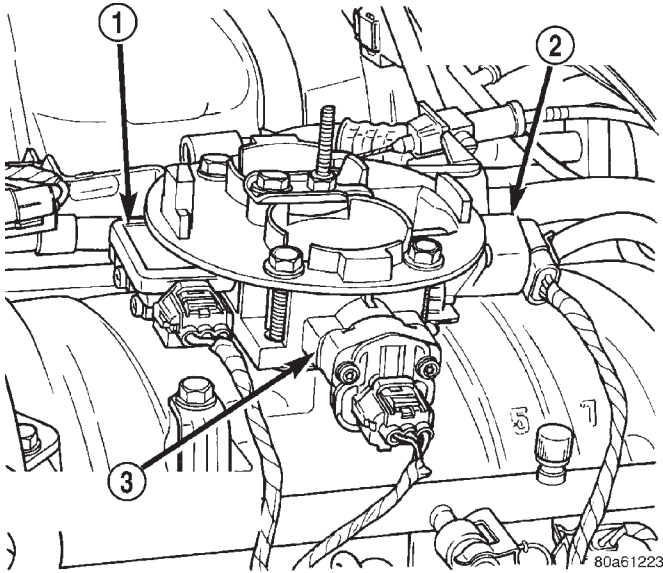
- 1 - INTAKE MANIFOLD AIR TEMPERATURE SENSOR
- 2 - ELECTRICAL CONNECTOR

(16) Verify MAP sensor electrical connector is firmly connected to MAP sensor (Fig. 8). Also verify rubber L-shaped fitting from MAP sensor to throttle body is firmly connected (Fig. 9).

(17) Verify fuel injector wire harness connectors are firmly connected to injectors in correct order. Each harness connector is numerically tagged with



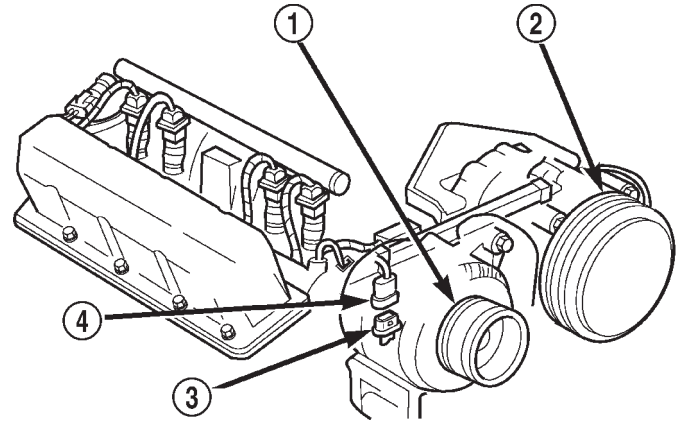
DIAGNOSIS AND TESTING (Continued)



**Fig. 8 Sensor and IAC Motor Location—Typical (V-8 Shown)**

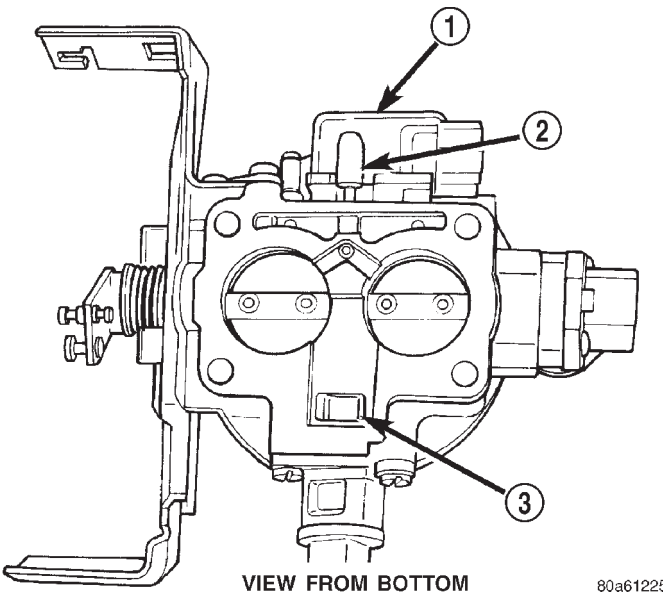
- 1 - MAP SENSOR
- 2 - IDLE AIR CONTROL MOTOR
- 3 - THROTTLE POSITION SENSOR

(19) Verify wire harness connector is firmly connected to engine coolant temperature sensor (Fig. 10).



**Fig. 10 Engine Coolant Temperature Sensor**

- 1 - GENERATOR
- 2 - A/C COMPRESSOR
- 3 - ENGINE COOLANT TEMPERATURE SENSOR
- 4 - ELEC. CONN.

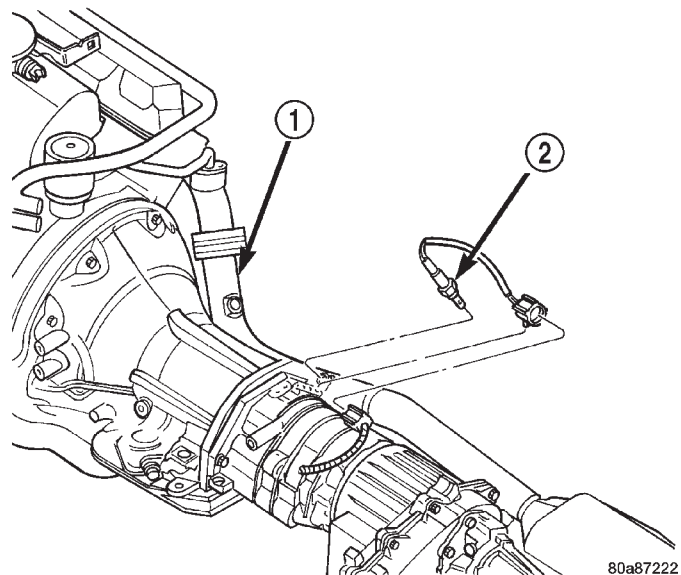


**Fig. 9 Rubber L-Shaped Fitting—MAP Sensor-to-Throttle Body**

- 1 - MAP SENSOR
- 2 - RUBBER FITTING
- 3 - IDLE AIR PASSAGE

(20) Raise and support vehicle.

(21) Verify both upstream and downstream oxygen sensor wire connectors are firmly connected to sensors. Inspect sensors and connectors for damage (Fig. 11) or (Fig. 12).



**Fig. 11 Upstream Oxygen Sensor**

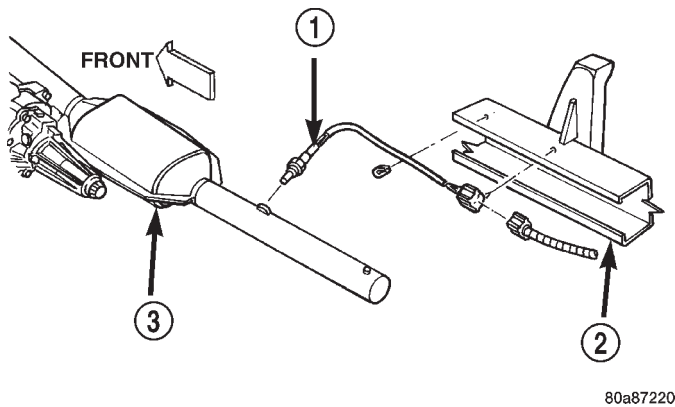
- 1 - EXHAUST PIPE
- 2 - UPSTREAM OXYGEN SENSOR

injector number (INJ 1, INJ 2 etc.) of its corresponding fuel injector and cylinder number.

(18) Verify harness connectors are firmly connected to idle air control (IAC) motor, throttle position sensor (TPS) and manifold absolute pressure (MAP) sensor (Fig. 8).

(22) Inspect for pinched or leaking fuel tubes. Inspect for pinched, cracked or leaking fuel hoses.

DIAGNOSIS AND TESTING (Continued)



**Fig. 12 Downstream Oxygen Sensor**

- 1 - DOWNSTREAM OXYGEN SENSOR
- 2 - FRAME RAIL
- 3 - CATALYTIC CONVERTER

(23) Inspect for exhaust system restrictions such as pinched exhaust pipes, collapsed muffler or plugged catalytic convertor.

(24) If equipped with automatic transmission, verify electrical harness is firmly connected to park/neutral switch. Refer to Automatic Transmission section of Group 21.

(25) Verify electrical harness is firmly connected to rear wheel speed sensor. Verify rear wheel speed sensor is firmly attached to rear axle with proper air gap. Refer to Group 5, Brakes for information.

(26) If equipped with 4-wheel antilock brake system, verify electrical harness is firmly connected to each front wheel speed sensor. Verify both front wheel speed sensors are firmly attached. Refer to Group 5, Brakes for information.

(27) Verify fuel pump/gauge sender unit wire connector is firmly connected to harness connector.

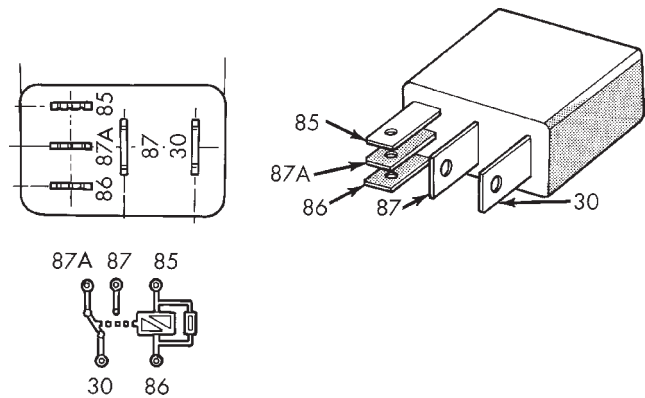
(28) Inspect fuel hoses at fuel pump/gauge sender unit for cracks or leaks.

(29) Inspect transmission torque convertor housing (automatic transmission) or clutch housing (manual transmission) for damage to timing ring on drive plate/flywheel.

(30) Verify battery cable and solenoid feed wire connections to starter solenoid are tight and clean. Inspect for chaffed wires or wires rubbing against other components.

**ASD AND FUEL PUMP RELAYS**

The following description of operation and tests apply only to the Automatic Shutdown (ASD) and fuel pump relays. The terminals on the bottom of each relay are numbered (Fig. 13).



TERMINAL LEGEND	
NUMBER	IDENTIFICATION
30	COMMON FEED
85	COIL GROUND
86	COIL BATTERY
87	NORMALLY OPEN
87A	NORMALLY CLOSED

**Fig. 13 ASD and Fuel Pump Relay Terminals**

**OPERATION**

- Terminal number 30 is connected to battery voltage. For both the ASD and fuel pump relays, terminal 30 is connected to battery voltage at all times.

- The PCM grounds the coil side of the relay through terminal number 85.

- Terminal number 86 supplies voltage to the coil side of the relay.

- When the PCM de-energizes the ASD and fuel pump relays, terminal number 87A connects to terminal 30. This is the Off position. In the off position, voltage is not supplied to the rest of the circuit. Terminal 87A is the center terminal on the relay.

- When the PCM energizes the ASD and fuel pump relays, terminal 87 connects to terminal 30. This is the On position. Terminal 87 supplies voltage to the rest of the circuit.

**TESTING**

The following procedure applies to the ASD and fuel pump relays.

(1) Remove relay from connector before testing.

(2) With the relay removed from the vehicle, use an ohmmeter to check the resistance between terminals 85 and 86. The resistance should be  $75 \pm 5$  ohms.

(3) Connect the ohmmeter between terminals 30 and 87A. The ohmmeter should show continuity between terminals 30 and 87A.

(4) Connect the ohmmeter between terminals 87 and 30. The ohmmeter should not show continuity at this time.

DIAGNOSIS AND TESTING (Continued)

(5) Connect one end of a jumper wire (16 gauge or smaller) to relay terminal 85. Connect the other end of the jumper wire to the ground side of a 12 volt power source.

(6) Connect one end of another jumper wire (16 gauge or smaller) to the power side of the 12 volt power source. **Do not attach the other end of the jumper wire to the relay at this time.**

**WARNING: DO NOT ALLOW OHMMETER TO CONTACT TERMINALS 85 OR 86 DURING THIS TEST.**

(7) Attach the other end of the jumper wire to relay terminal 86. This activates the relay. The ohmmeter should now show continuity between relay terminals 87 and 30. The ohmmeter should not show continuity between relay terminals 87A and 30.

(8) Disconnect jumper wires.

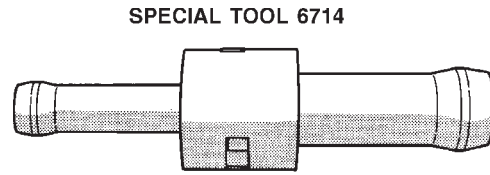
(9) Replace the relay if it did not pass the continuity and resistance tests. If the relay passed the tests, it operates properly. Check the remainder of the ASD and fuel pump relay circuits. Refer to group 8W, Wiring Diagrams.

**THROTTLE BODY MINIMUM AIR FLOW CHECK PROCEDURE**

**3.9/5.2/5.9L ENGINES**

The following test procedure has been developed to check throttle body calibrations for correct idle conditions. The procedure should be used to diagnose the throttle body for conditions that may cause idle problems. **This procedure should be used only after normal diagnostic procedures have failed to produce results that indicate a throttle body related problem. Be sure to check for proper operation of the idle air control motor before performing this test.**

A special fixed orifice tool (number 6714) (Fig. 14) must be used for the following test.



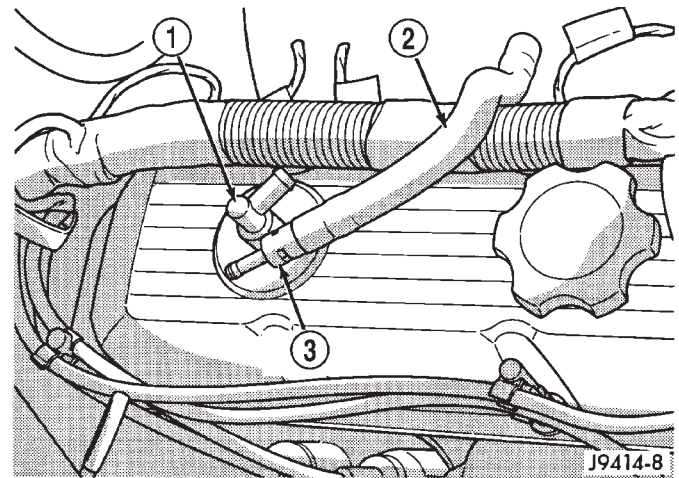
J9414-7

**Fig. 14 Fixed Orifice Tool**

(1) Start the engine and bring to operating temperature. Be sure all accessories are off before performing this test.

(2) Shut off the engine and remove the air duct at throttle body.

(3) Disconnect the vacuum line at the PCV valve (Fig. 15).



J9414-8

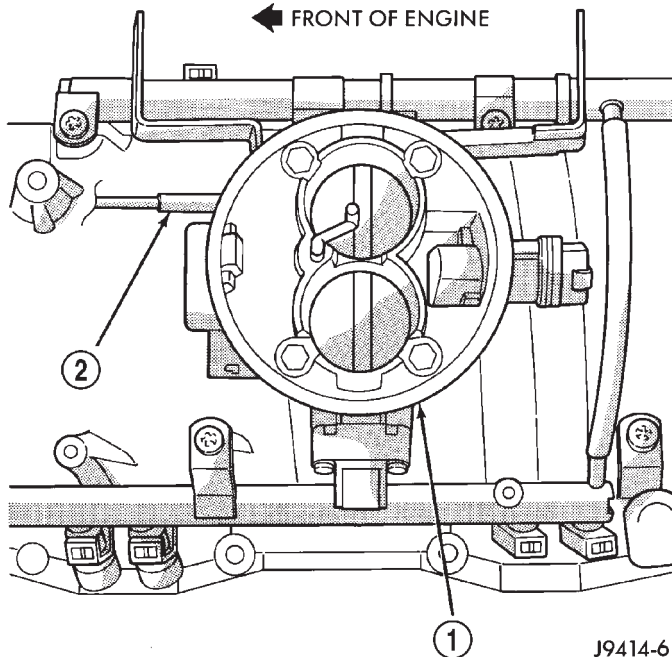
**Fig. 15 Install Orifice Tool**

- 1 - PCV VALVE
- 2 - VACUUM LINE
- 3 - ORIFICE TOOL

(4) Install the 0.185 inch orifice tool (number 6714) into the disconnected vacuum line in place of the PCV valve (Fig. 15).

## DIAGNOSIS AND TESTING (Continued)

(5) Disconnect the idle purge vacuum line from fitting at throttle body. This vacuum line is located on the front of throttle body next to the MAP sensor (Fig. 16). Cap the fitting at throttle body after vacuum line has been removed.



**Fig. 16 Idle Purge Line**

- 1 - THROTTLE BODY  
2 - PURGE VACUUM LINE

(6) Connect the DRB scan tool to the 16-way data link connector. This connector is located under the instrument panel to the left of the steering column. Refer to the appropriate Powertrain Diagnostic Procedures service manual for DRB operation.

(7) Start the engine and allow to warm up.

(8) Using the DRB scan tool, scroll through the menus as follows: select—Stand Alone DRB III, select the year 2000 Diagnostics, select—Engine, select—System Test, select—Minimum Air Flow.

(9) The DRB scan tool will count down to stabilize the idle rpm and display the minimum air flow idle rpm. The idle rpm should be between **500 and 900 rpm**. If the idle speed is outside of these specifications, replace the throttle body. Refer to Throttle Body in the Component Removal/Installation section of this group.

(10) Disconnect the DRB scan tool from the vehicle.

(11) Remove cap from idle purge fitting at throttle body and install vacuum line.

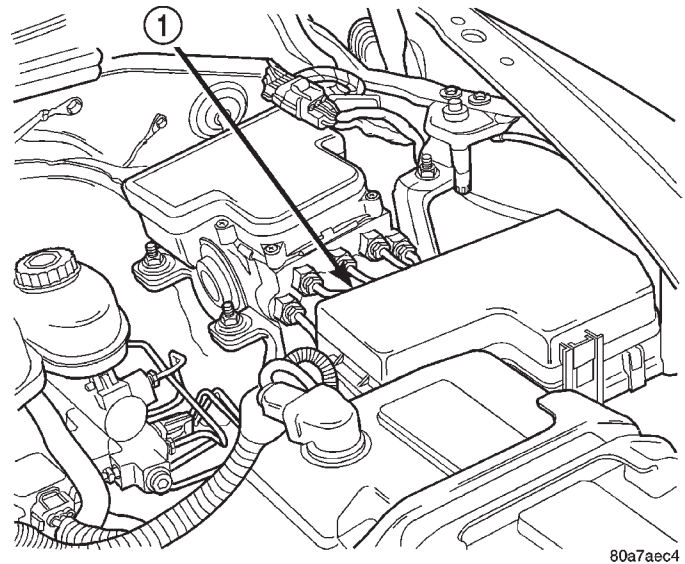
(12) Remove orifice tool and connect vacuum line to PCV valve.

(13) Install air duct to throttle body.

## REMOVAL AND INSTALLATION

## AUTOMATIC SHUTDOWN (ASD) RELAY

The ASD relay is located in the Power Distribution Center (PDC) (Fig. 17). Refer to label on PDC cover for relay location.



**Fig. 17 Power Distribution Center (PDC) Location**

- 1 - POWER DISTRIBUTION CENTER (PDC)

## REMOVAL

- (1) Remove PDC cover.
- (2) Remove relay from PDC.
- (3) Check condition of relay terminals and PDC connector terminals for damage or corrosion. Repair if necessary before installing relay.
- (4) Check for pin height (pin height should be the same for all terminals within the PDC connector). Repair if necessary before installing relay.

## INSTALLATION

- (1) Install relay to PDC.
- (2) Install cover to PDC.

## FUEL PUMP RELAY

The fuel pump relay is located in the Power Distribution Center (PDC) (Fig. 17). Refer to label on PDC cover for relay location.

## REMOVAL

- (1) Remove PDC cover.
- (2) Remove relay from PDC.
- (3) Check condition of relay terminals and PDC connector terminals for damage or corrosion. Repair if necessary before installing relay.
- (4) Check for pin height (pin height should be the same for all terminals within the PDC connector). Repair if necessary before installing relay.

REMOVAL AND INSTALLATION (Continued)

**INSTALLATION**

- (1) Install relay to PDC.
- (2) Install cover to PDC.

**OXYGEN SENSOR HEATER RELAYS**

The oxygen sensor heater relays are located in the Power Distribution Center (PDC) (Fig. 17). Refer to label on PDC cover for relay location.

**REMOVAL**

- (1) Remove PDC cover.
- (2) Remove relay from PDC.
- (3) Check condition of relay terminals and PDC connector terminals for damage or corrosion. Repair if necessary before installing relay.
- (4) Check for pin height (pin height should be the same for all terminals within the PDC connector). Repair if necessary before installing relay.

**INSTALLATION**

- (1) Install relay to PDC.
- (2) Install cover to PDC.

**THROTTLE BODY—3.9/5.2/5.9L ENGINES**

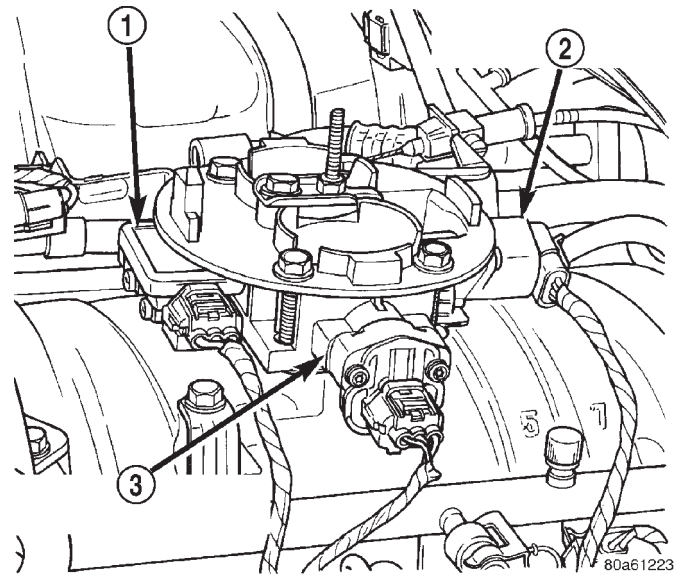
A (factory adjusted) set screw is used to mechanically limit the position of the throttle body throttle plate. **Never attempt to adjust the engine idle speed using this screw.** All idle speed functions are controlled by the powertrain control module (PCM).

**REMOVAL**

- (1) Remove the air duct at throttle body.
- (2) Disconnect throttle body electrical connectors at MAP sensor, IAC motor and TPS (Fig. 18).
- (3) Remove vacuum line at throttle body.
- (4) Remove all control cables from throttle body (lever) arm. Refer to the Accelerator Pedal and Throttle Cable section of this group for additional information.
- (5) Remove four throttle body mounting bolts (Fig. 19).
- (6) Remove throttle body from intake manifold.
- (7) Discard old throttle body-to-intake manifold gasket.

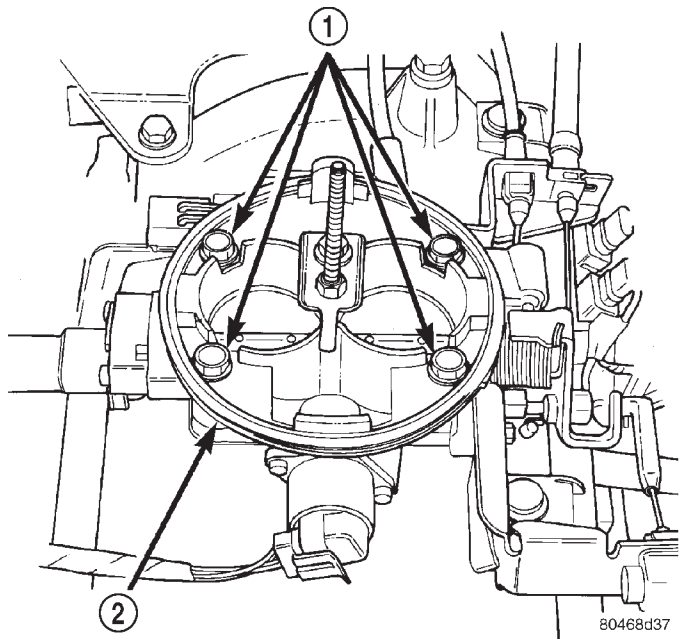
**INSTALLATION**

- (1) Clean the mating surfaces of the throttle body and the intake manifold.
- (2) Install new throttle body-to-intake manifold gasket.
- (3) Install throttle body to intake manifold.
- (4) Install four mounting bolts. Tighten bolts to 23 N·m (200 in. lbs.) torque.
- (5) Install control cables.
- (6) Install vacuum line to throttle body.
- (7) Install electrical connectors.



**Fig. 18 Sensor Electrical Connectors—3.9/5.2/5.9L Engines—Typical**

- 1 - MAP SENSOR
- 2 - IDLE AIR CONTROL MOTOR
- 3 - THROTTLE POSITION SENSOR



**Fig. 19 Throttle Body Mounting Bolts—3.9/5.2/5.9L Engines—Typical**

- 1 - THROTTLE BODY MOUNTING BOLTS (4)
- 2 - THROTTLE BODY

- (8) Install air duct at throttle body.

**THROTTLE BODY—4.7L V-8 ENGINE**

A (factory adjusted) set screw is used to mechanically limit the position of the throttle body throttle

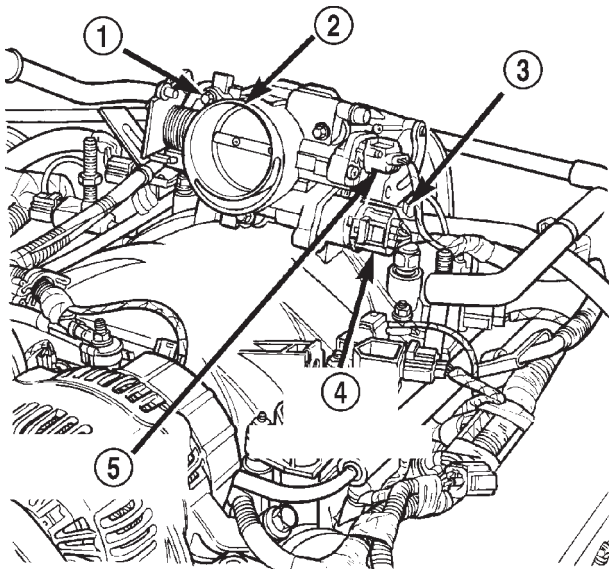
## REMOVAL AND INSTALLATION (Continued)

plate. **Never attempt to adjust the engine idle speed using this screw.** All idle speed functions are controlled by the Powertrain Control Module (PCM).

## REMOVAL

(1) Remove the air duct and air resonator box at throttle body.

(2) Disconnect throttle body electrical connectors at IAC motor and TPS (Fig. 20).



80b898f6

**Fig. 20 Throttle Body, Sensors and Electrical Connectors—4.7L V-8 Engine**

- 1 - MOUNTING BOLTS (3)
- 2 - THROTTLE BODY
- 3 - IAT SENSOR CONNECTOR
- 4 - IAC MOTOR CONNECTOR
- 5 - TPS CONNECTOR

- (3) Remove vacuum line at throttle body.
- (4) Remove all control cables from throttle body (lever) arm. Refer to Accelerator Pedal and Throttle Cable.
- (5) Remove three throttle body mounting bolts (Fig. 20).
- (6) Remove throttle body from intake manifold.

## INSTALLATION

- (1) Clean throttle body-to-intake manifold o-ring.
- (2) Clean mating surfaces of throttle body and intake manifold.
- (3) Install throttle body to intake manifold by positioning throttle body to manifold alignment pins.
- (4) Install three mounting bolts. Tighten bolts to 12 N·m (105 in. lbs.) torque.
- (5) Install control cables.
- (6) Install vacuum line to throttle body.
- (7) Install electrical connectors.

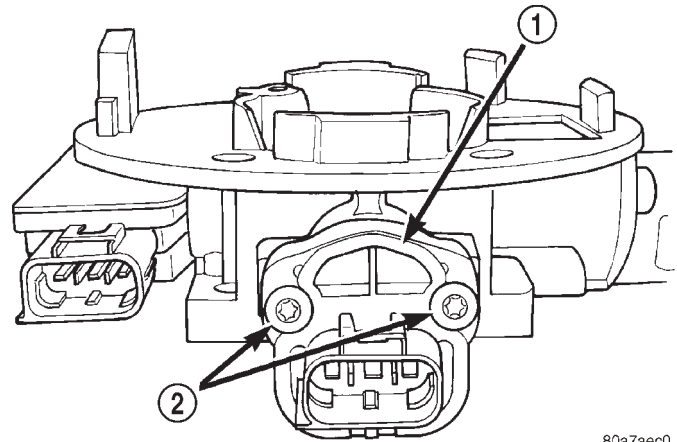
- (8) Install air duct/air box at throttle body.

## THROTTLE POSITION SENSOR (TPS)—3.9/5.2/5.9L ENGINES

## REMOVAL

The TPS is located on side of throttle body.

- (1) Remove air duct at throttle body.
- (2) Disconnect TPS electrical connector.
- (3) Remove two TPS mounting bolts (Fig. 21).



80a7aec0

**Fig. 21 TPS Mounting Bolts—3.9/5.2/5.9L Engines**

- 1 - THROTTLE POSITION SENSOR
- 2 - MOUNTING SCREWS

- (4) Remove TPS from throttle body.

## INSTALLATION

The throttle shaft end of the throttle body slides into a socket in the TPS (Fig. 22). The TPS must be installed so that it can be rotated a few degrees. If the sensor will not rotate, install the sensor with the throttle shaft on the other side of the socket tangs. The TPS will be under slight tension when rotated.

- (1) Install the TPS and two retaining bolts.
- (2) Tighten bolts to 7 N·m (60 in. lbs.) torque.
- (3) Manually operate the throttle control lever by hand to check for any binding of the TPS.
- (4) Connect TPS electrical connector to TPS.
- (5) Install air duct at throttle body.

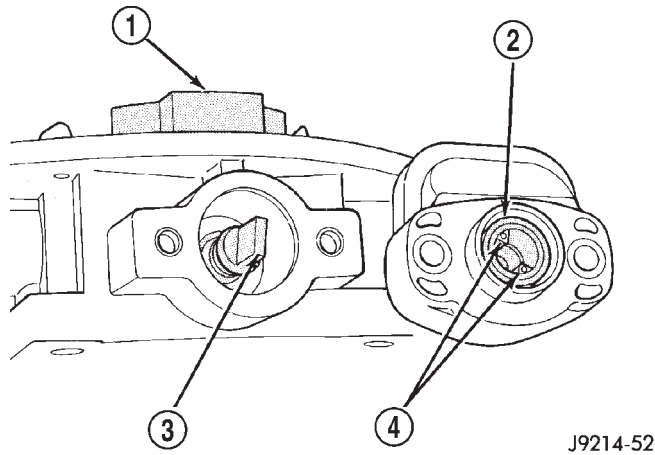
## THROTTLE POSITION SENSOR (TPS)—4.7L V-8 ENGINE

## REMOVAL

The TPS is located on the throttle body.

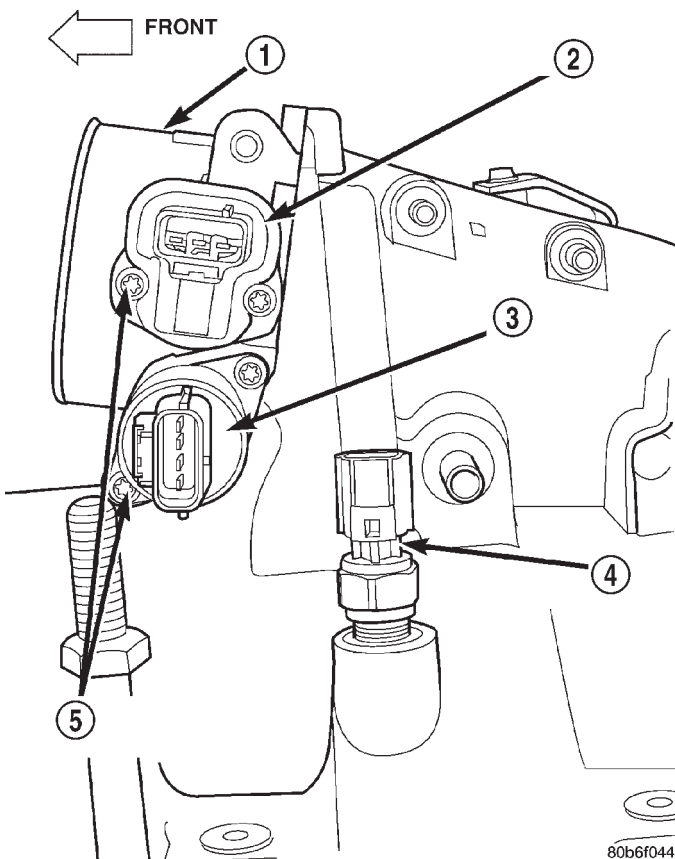
- (1) Remove air duct and air resonator box at throttle body.
- (2) Disconnect TPS electrical connector (Fig. 20).
- (3) Remove two TPS mounting bolts (screws) (Fig. 23).

REMOVAL AND INSTALLATION (Continued)



**Fig. 22 Installation—3.9/5.2/5.9L Engines—Typical**

- 1 - THROTTLE BODY
- 2 - THROTTLE POSITION SENSOR
- 3 - THROTTLE SHAFT
- 4 - SOCKET LOCATING TANGS



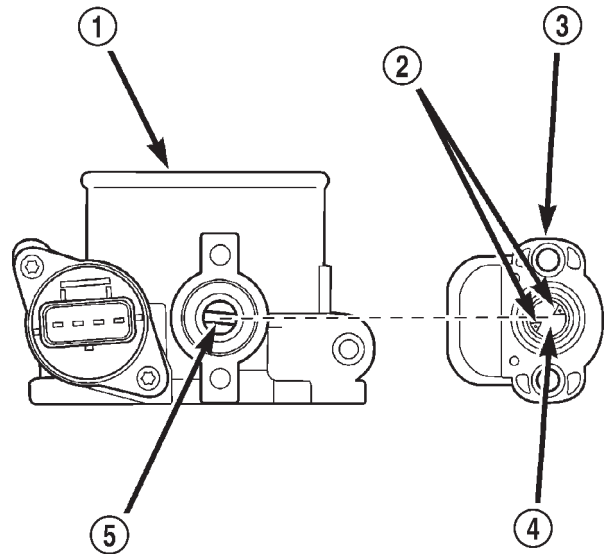
**Fig. 23 TPS Mounting Bolts—4.7L V-8 Engine**

- 1 - THROTTLE BODY
- 2 - TPS
- 3 - IAC MOTOR
- 4 - IAT SENSOR
- 5 - MOUNTING SCREWS

(4) Remove TPS from throttle body.

**INSTALLATION**

The throttle shaft end of throttle body slides into a socket in TPS (Fig. 24). The TPS must be installed so that it can be rotated a few degrees. If sensor will not rotate, install sensor with throttle shaft on other side of socket tangs. The TPS will be under slight tension when rotated.



**Fig. 24 TPS Installation—4.7L V-8 Engine**

- 1 - THROTTLE BODY
- 2 - LOCATING TANGS
- 3 - THROTTLE POSITION SENSOR
- 4 - SOCKET
- 5 - THROTTLE SHAFT

- (1) Install TPS and two retaining bolts.
- (2) Tighten bolts to 7 N·m (60 in. lbs.) torque.
- (3) Manually operate throttle control lever by hand to check for any binding of TPS.
- (4) Connect TPS electrical connector to TPS.
- (5) Install air duct/air box to throttle body.

**IDLE AIR CONTROL (IAC) MOTOR—3.9/5.2/5.9L ENGINES**

The IAC motor is located on the back of the throttle body (Fig. 25).

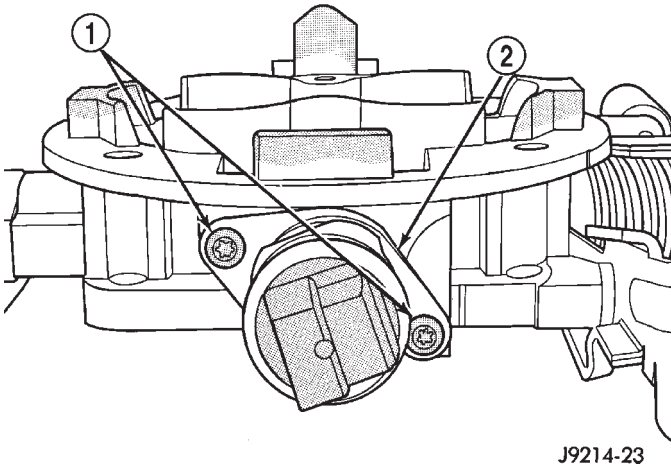
**REMOVAL**

- (1) Remove air duct at throttle body.
- (2) Disconnect electrical connector from IAC motor.
- (3) Remove two mounting bolts (screws) (Fig. 25).
- (4) Remove IAC motor from throttle body.

**INSTALLATION**

- (1) Install IAC motor to throttle body.

## REMOVAL AND INSTALLATION (Continued)



J9214-23

**Fig. 25 Mounting Bolts (Screws)—IAC Motor—3.9/5.2/5.9L Engines**

- 1 - MOUNTING SCREWS  
2 - IDLE SPEED MOTOR

- (2) Install and tighten two mounting bolts (screws) to 7 N·m (60 in. lbs.) torque.
- (3) Install electrical connector.
- (4) Install air duct at throttle body.

### IDLE AIR CONTROL (IAC) MOTOR—4.7L V-8 ENGINE

The IAC motor is located on the throttle body.

#### REMOVAL

- (1) Remove air duct and air resonator box at throttle body.
- (2) Disconnect electrical connector from IAC motor (Fig. 20).
- (3) Remove two mounting bolts (screws) (Fig. 21).
- (4) Remove IAC motor from throttle body.

#### INSTALLATION

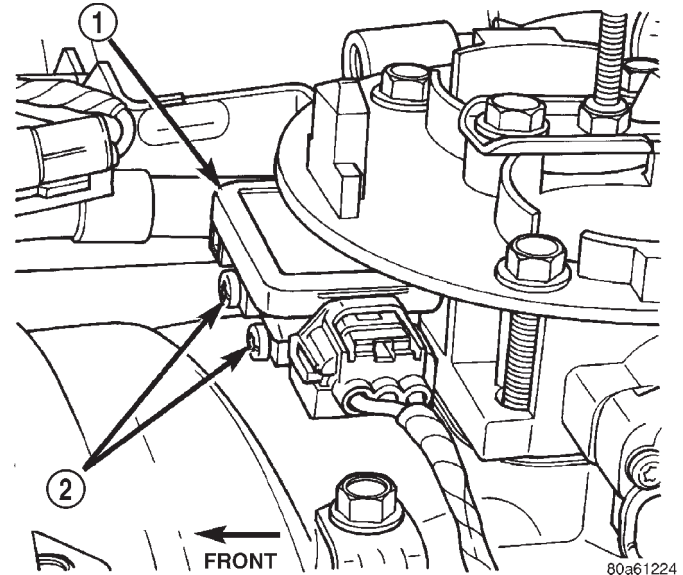
- (1) Install IAC motor to throttle body.
- (2) Install and tighten two mounting bolts (screws) to 7 N·m (60 in. lbs.) torque.
- (3) Install electrical connector.
- (4) Install air duct/air box to throttle body.

### MANIFOLD ABSOLUTE PRESSURE (MAP) SENSOR—3.9/5.2/5.9L ENGINES

The MAP sensor is located on the front of the throttle body (Fig. 26). An L-shaped rubber fitting is used to connect the MAP sensor to throttle body (Fig. 27).

#### REMOVAL

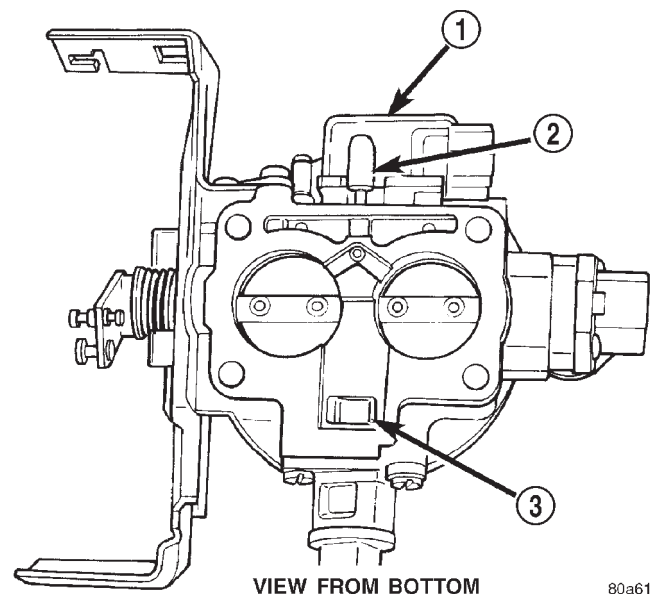
- (1) Remove air duct at throttle body.
- (2) Remove two MAP sensor mounting bolts (screws) (Fig. 26).



80a61224

**Fig. 26 MAP Sensor Location—3.9/5.2/5.9L Engines**

- 1 - MAP SENSOR  
2 - MOUNTING SCREWS (2)



80a61225

**Fig. 27 MAP Sensor L-Shaped Rubber Fitting—3.9/5.2/5.9L Engines**

- 1 - MAP SENSOR  
2 - RUBBER FITTING  
3 - IDLE AIR PASSAGE

- (3) While removing MAP sensor, slide the vacuum rubber L-shaped fitting (Fig. 27) from the throttle body.
- (4) Remove rubber L-shaped fitting from MAP sensor.

#### INSTALLATION

- (1) Install rubber L-shaped fitting to MAP sensor.

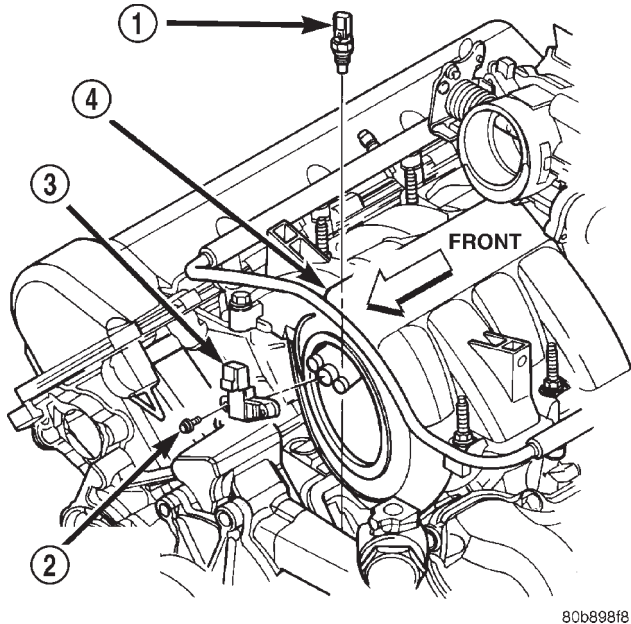


REMOVAL AND INSTALLATION (Continued)

- (2) Position sensor to throttle body while guiding rubber fitting over throttle body vacuum nipple.
- (3) Install MAP sensor mounting bolts (screws). Tighten screws to 3 N·m (25 in. lbs.) torque.
- (4) Install air duct at throttle body.

**MANIFOLD ABSOLUTE PRESSURE (MAP) SENSOR—4.7L V-8 ENGINE**

The MAP sensor is located on the front of the intake manifold (Fig. 28). An o-ring seals the sensor to the intake manifold.



**Fig. 28 MAP and ECT Sensor Locations—4.7L V-8 Engine**

- 1 - ECT SENSOR
- 2 - MOUNTING BOLTS (2)
- 3 - MAP SENSOR
- 4 - INTAKE MANIFOLD

**REMOVAL**

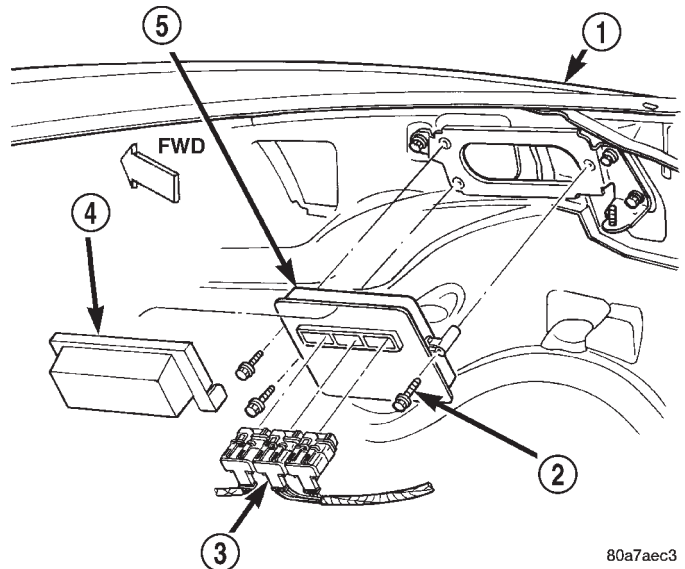
- (1) Disconnect electrical connector at sensor.
- (2) Clean area around MAP sensor.
- (3) Remove 2 sensor mounting bolts (Fig. 28).
- (4) Remove MAP sensor from intake manifold.

**INSTALLATION**

- (1) Clean MAP sensor mounting hole at intake manifold.
- (2) Check MAP sensor o-ring seal for cuts or tears.
- (3) Position sensor into manifold.
- (4) Install MAP sensor mounting bolts (screws). Tighten screws to 3 N·m (25 in. lbs.) torque.
- (5) Connect electrical connector.

**POWERTRAIN CONTROL MODULE (PCM)**

The PCM is located in the engine compartment (Fig. 29).



**Fig. 29 PCM Location and Mounting**

- 1 - RIGHT FRONT FENDER
- 2 - PCM MOUNTING BOLTS (3)
- 3 - 32-WAY CONNECTORS (3)
- 4 - COVER
- 5 - POWERTRAIN CONTROL MODULE (PCM)

**REMOVAL**

To avoid possible voltage spike damage to the PCM, ignition key must be off, and negative battery cable must be disconnected before unplugging PCM connectors.

- (1) Disconnect negative battery cable at battery.
- (2) Remove cover over electrical connectors. Cover snaps onto PCM.
- (3) Carefully unplug the three 32-way connectors from PCM.
- (4) Remove three PCM mounting bolts and remove PCM from vehicle.

**INSTALLATION**

- (1) Install PCM and mounting bolts to vehicle.
- (2) Tighten bolts to 3-5 N·m (30-40 in. lbs.).
- (3) Check pin connectors in the PCM and the three 32-way connectors for corrosion or damage. Repair as necessary.
- (4) Install three 32-way connectors.
- (5) Install cover over electrical connectors. Cover snaps onto PCM.
- (6) Install battery cable.
- (7) Use the DRB scan tool to reprogram new PCM with vehicles original Identification Number (VIN) and original vehicle mileage. If this step is not done, a Diagnostic Trouble Code (DTC) may be set.

## REMOVAL AND INSTALLATION (Continued)

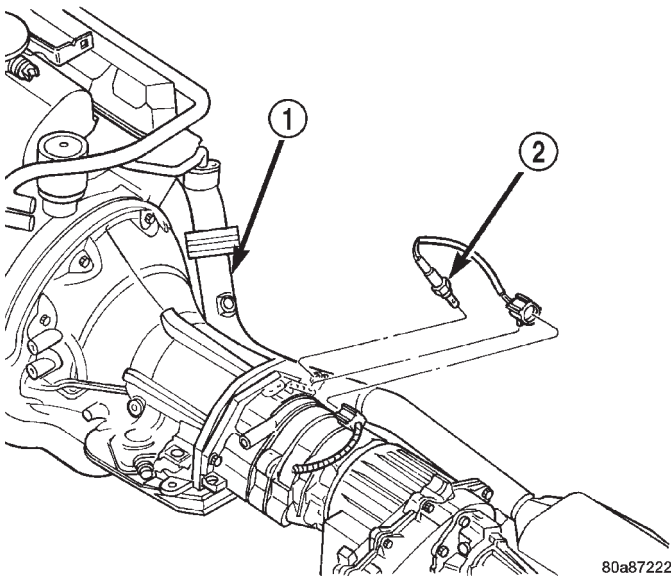
## OXYGEN SENSOR

## REMOVAL

Never apply any type of grease to the oxygen sensor electrical connector, or attempt any soldering of the sensor wiring harness. For sensor operation, it must have a comparison source of oxygen from outside the exhaust system. This fresh air is supplied to the sensor through its pigtail wiring harness.

5.2L/5.9L Engines: The upstream O2S sensor is located on exhaust downpipe (Fig. 30). The downstream sensor is located near outlet end of catalytic converter (Fig. 31).

4.7L V-8 Engines: Refer to (Fig. 32) for locations.



**Fig. 30 Upstream Oxygen Sensor Locations—5.2L/5.9L V-8 Engines**

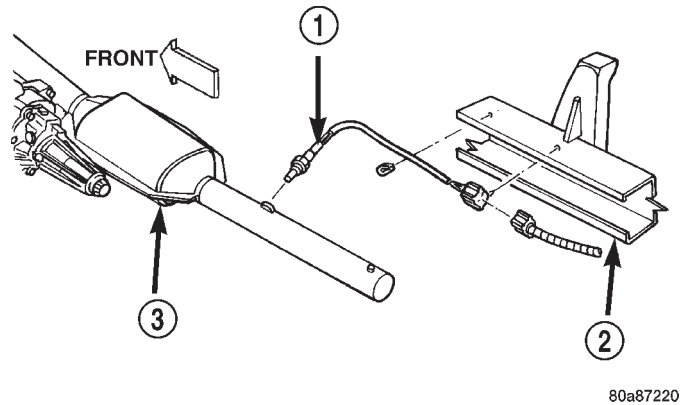
- 1 - EXHAUST PIPE  
2 - UPSTREAM OXYGEN SENSOR

**WARNING: THE EXHAUST MANIFOLD, EXHAUST PIPES AND CATALYTIC CONVERTER BECOME VERY HOT DURING ENGINE OPERATION. ALLOW ENGINE TO COOL BEFORE REMOVING OXYGEN SENSOR.**

- (1) Raise and support the vehicle.
- (2) Disconnect the wire connector from the O2S sensor.

**CAUTION: When disconnecting the sensor electrical connector, do not pull directly on wire going into sensor.**

- (3) Remove the O2S sensor with an oxygen sensor removal and installation tool.



**Fig. 31 Downstream Oxygen Sensor Location—5.2L/5.9L V-8 Engines**

- 1 - DOWNSTREAM OXYGEN SENSOR  
2 - FRAME RAIL  
3 - CATALYTIC CONVERTER

## INSTALLATION

Threads of new oxygen sensors are factory coated with anti-seize compound to aid in removal. **DO NOT add any additional anti-seize compound to the threads of a new oxygen sensor.**

- (1) Install the O2S sensor. Tighten to 30 N·m (22 ft. lbs.) torque.
- (2) Connect the O2S sensor wire connector.
- (3) Lower the vehicle.

## AIR CLEANER ELEMENT (FILTER)

## REMOVAL

Housing removal is not necessary for element (filter) replacement.

- (1) Pry up spring clips from housing cover (spring clips retain cover to housing).
- (2) Release housing cover from locating tabs on housing (Fig. 33) and remove cover.
- (3) Remove air cleaner element (filter) from housing.
- (4) Clean inside of housing before replacing element.

## INSTALLATION

- (1) Install element into housing.
- (2) Position housing cover into housing locating tabs.
- (3) Pry up spring clips and lock cover to housing.

## ENGINE COOLANT TEMPERATURE SENSOR—3.9/5.2/5.9L ENGINES

The engine coolant temperature sensor is installed into a water jacket at front of intake manifold near rear of generator (Fig. 34).

REMOVAL AND INSTALLATION (Continued)

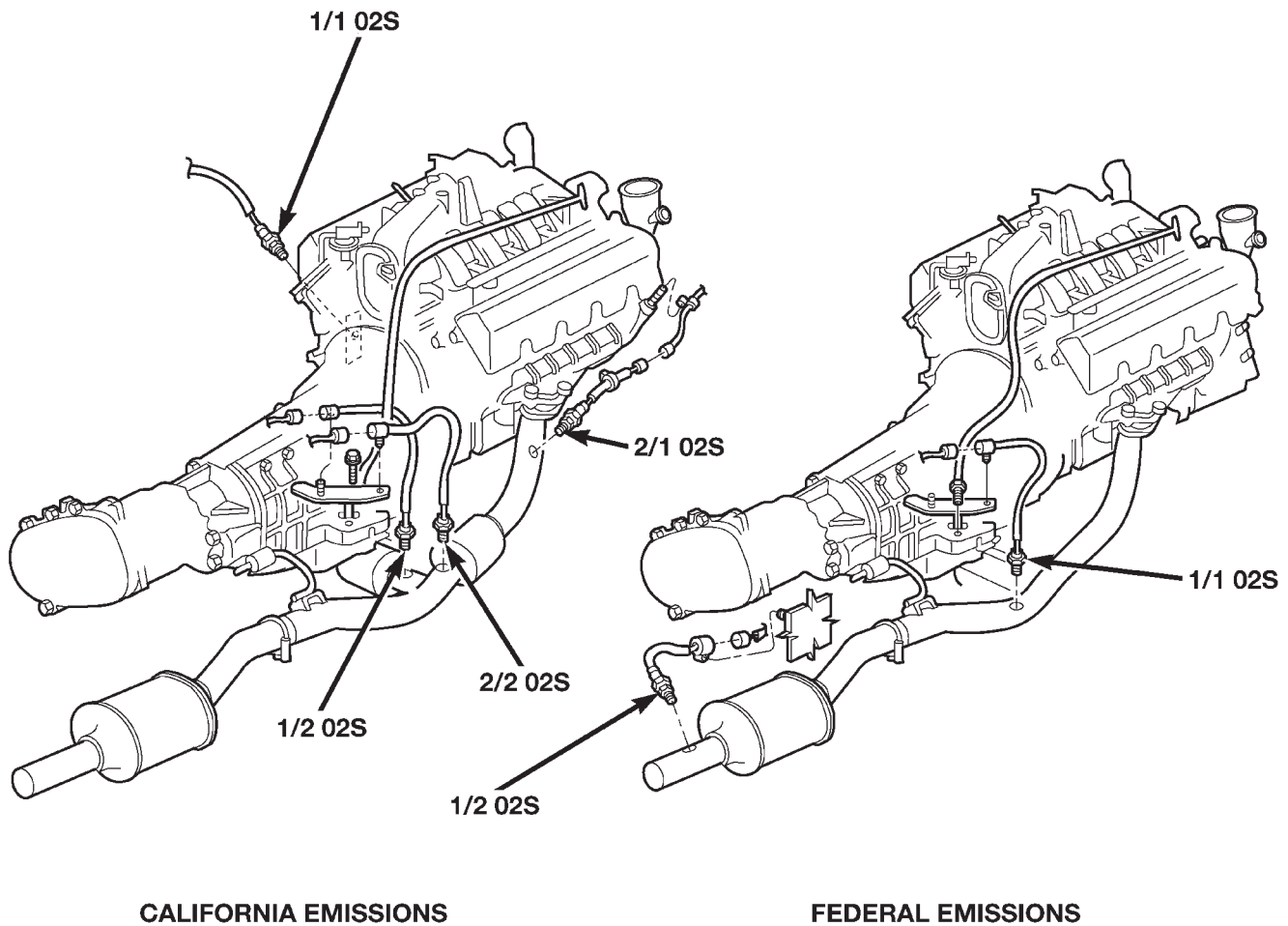


Fig. 32 Oxygen Sensor Locations—4.7L V-8 Engine

REMOVAL

**WARNING: HOT, PRESSURIZED COOLANT CAN CAUSE INJURY BY SCALDING. COOLING SYSTEM MUST BE PARTIALLY DRAINED BEFORE REMOVING THE COOLANT TEMPERATURE SENSOR. REFER TO GROUP 7, COOLING.**

- (1) Partially drain cooling system. Refer to Group 7, Cooling.
- (2) Disconnect electrical connector from sensor (Fig. 34).
- (3) **Engines with air conditioning:** When removing the connector from sensor, do not pull directly on wiring harness. Fabricate an L-shaped hook tool from a coat hanger (approximately eight inches long). Place the hook part of tool under the connector for removal. The connector is snapped onto the sensor. It is not equipped with a lock type tab.
- (4) Remove sensor from intake manifold.

INSTALLATION

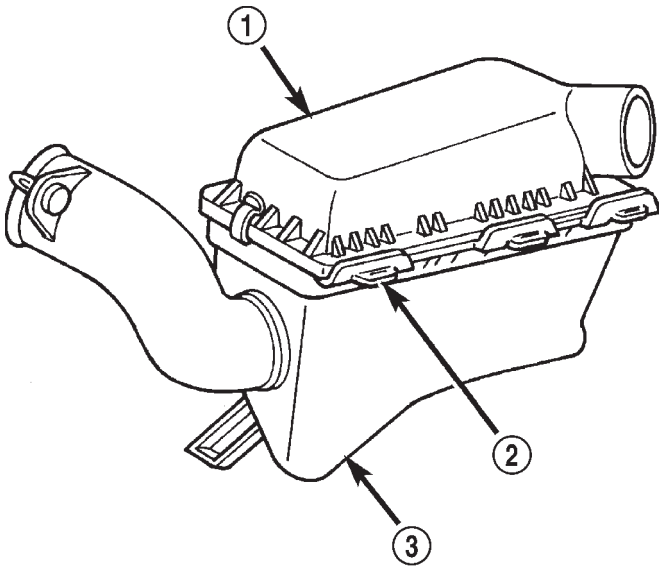
- (1) Install sensor.
- (2) Tighten to 11 N·m (8 ft. lbs.) torque.
- (3) Use long needlenose pliers to connect electrical connector to sensor. The sensor connector is symmetrical (not indexed). It can be installed to the sensor in either direction.
- (4) Replace any lost engine coolant. Refer to Group 7, Cooling System.

ENGINE COOLANT TEMPERATURE SENSOR—4.7L V-8 ENGINE

REMOVAL

**WARNING: HOT, PRESSURIZED COOLANT CAN CAUSE INJURY BY SCALDING. COOLING SYSTEM MUST BE PARTIALLY DRAINED BEFORE REMOVING THE ENGINE COOLANT TEMPERATURE (ECT) SENSOR. REFER TO GROUP 7, COOLING.**

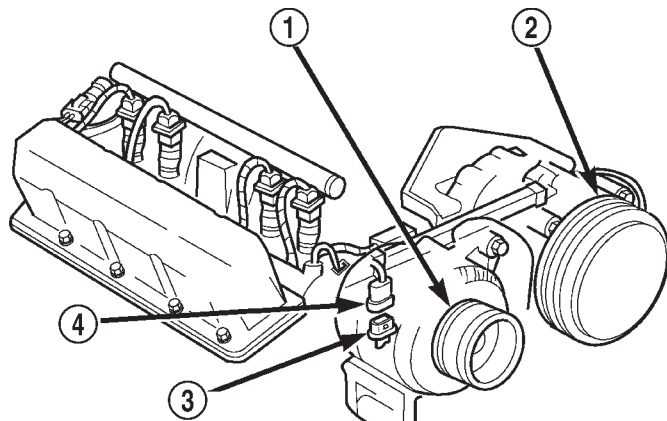
## REMOVAL AND INSTALLATION (Continued)



80bfe157

**Fig. 33 Air Cleaner Housing Assembly**

- 1 - AIR CLEANER ELEMENT COVER
- 2 - TABS
- 3 - HOUSING



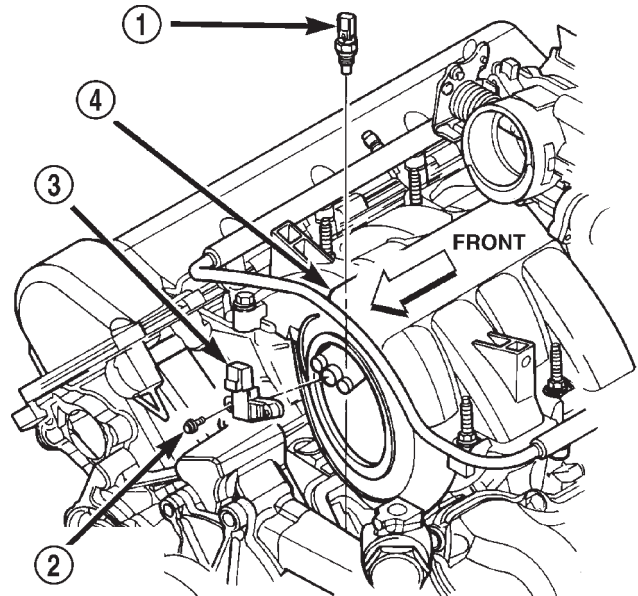
80b1b2f7

**Fig. 34 Engine Coolant Temperature Sensor—3.9/5.2/5.9L Engines—Typical**

- 1 - GENERATOR
- 2 - A/C COMPRESSOR
- 3 - ENGINE COOLANT TEMPERATURE SENSOR
- 4 - ELEC. CONN.

The ECT sensor is located near the front of the intake manifold (Fig. 35).

- (1) Partially drain cooling system. Refer to Group 7, Cooling.
- (2) Disconnect electrical connector from ECT sensor.
- (3) Remove sensor from intake manifold.



80b898f8

**Fig. 35 Engine Coolant Temperature Sensor—4.7L V-8 Engine**

- 1 - ECT SENSOR
- 2 - MOUNTING BOLTS (2)
- 3 - MAP SENSOR
- 4 - INTAKE MANIFOLD

**INSTALLATION**

- (1) Install sensor.
- (2) Tighten to 11 N·m (8 ft. lbs.) torque.
- (3) Connect electrical connector to sensor.
- (4) Replace any lost engine coolant. Refer to Group 7, Cooling System.

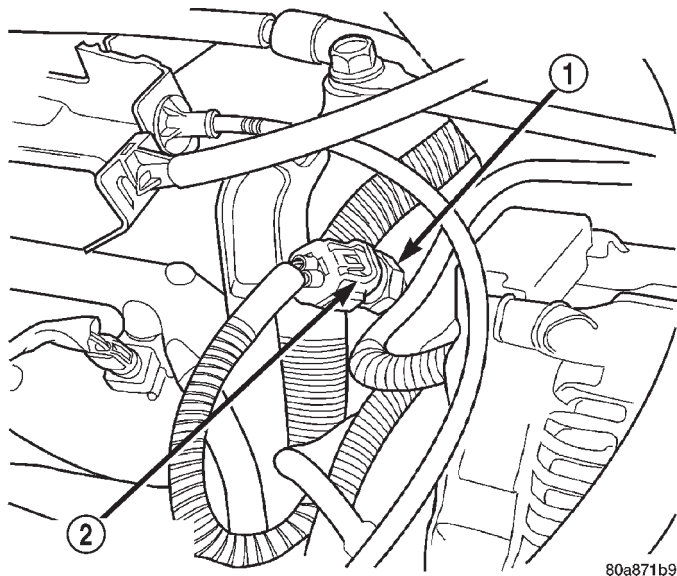
**INTAKE MANIFOLD AIR TEMPERATURE SENSOR—3.9/5.2/5.9L ENGINES**

The intake manifold air temperature sensor is located in the front/side of the intake manifold (Fig. 36).

**REMOVAL**

- (1) Remove air duct at throttle body.
- (2) Disconnect electrical connector at sensor (Fig. 36).
- (3) Remove sensor from intake manifold.

REMOVAL AND INSTALLATION (Continued)



80a871b9

**Fig. 36 Intake Manifold Air Temperature Sensor—  
3.9/5.2/5.9L Engines—Typical**

- 1 - INTAKE MANIFOLD AIR TEMPERATURE SENSOR
- 2 - ELECTRICAL CONNECTOR

**INSTALLATION**

- (1) Install sensor to intake manifold. Tighten to 28 N·m (20 ft. lbs.) torque.
- (2) Install electrical connector.
- (3) Install air duct at throttle body.

**INTAKE MANIFOLD AIR TEMPERATURE SENSOR—4.7L V-8 ENGINE**

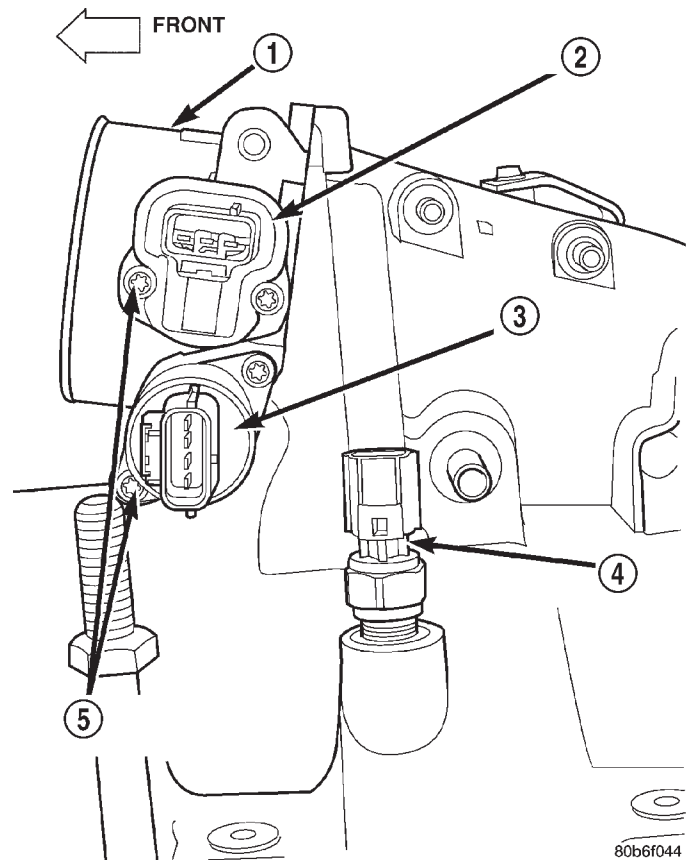
The Intake Manifold Air Temperature (IAT) sensor is installed into the intake manifold plenum near the left side of the throttle body (Fig. 37).

**REMOVAL**

- (1) Disconnect electrical connector from sensor.
- (2) Remove sensor from intake manifold.

**INSTALLATION**

- (1) Install sensor into intake manifold. Tighten sensor to 28 N·m (20 ft. lbs.) torque.
- (2) Connect electrical connector to sensor.



80b6f044

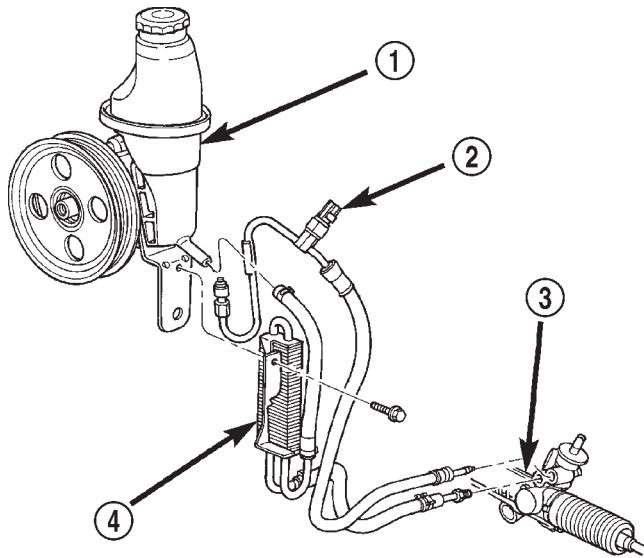
**Fig. 37 Intake Manifold Air Sensor Location—4.7L  
V-8 Engine**

- 1 - THROTTLE BODY
- 2 - TPS
- 3 - IAC MOTOR
- 4 - IAT SENSOR
- 5 - MOUNTING SCREWS

REMOVAL AND INSTALLATION (Continued)

**POWER STEERING PRESSURE SWITCH**

This switch is used only with 4.7L V-8 engine.  
 The power steering pressure switch is installed in the power steering high-pressure hose (Fig. 38).



80bfe152

**Fig. 38 Power Steering Pressure Switch—4.7L Engine**

- 1 - HYDRAULIC PUMP
- 2 - POWER STEERING PRESSURE SWITCH
- 3 - RACK AND PINION GEAR
- 4 - OIL COOLER

**REMOVAL**

- (1) Disconnect electrical connector from power steering pressure switch.
- (2) Place a small container or shop towel beneath switch to collect any excess fluid.
- (3) Remove switch. Use back-up wrench on power steering line to prevent line bending.

**INSTALLATION**

- (1) Install power steering switch into power steering line.
- (2) Tighten to 14–22 N·m (124–195 in. lbs.) torque.
- (3) Connect electrical connector to switch.
- (4) Check power steering fluid and add as necessary.
- (5) Start engine and again check power steering fluid. Add fluid if necessary.

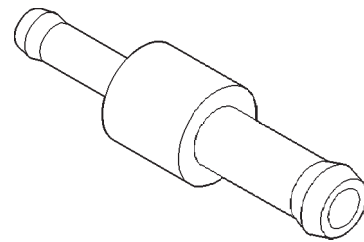
**SPECIFICATIONS**

**TORQUE CHART**

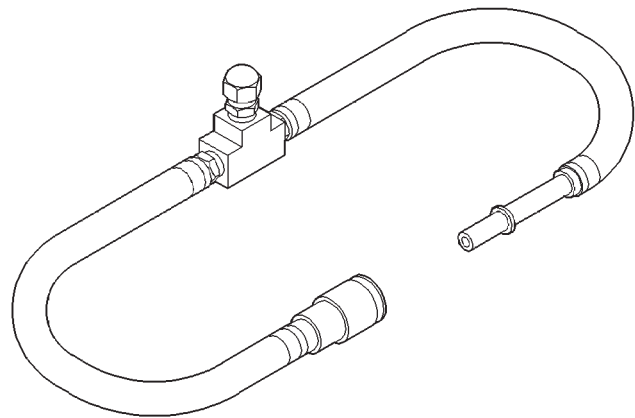
DESCRIPTION	TORQUE
Engine Coolant Temperature Sensor—All Engines . . . . .	11 N·m (96 in. lbs.)
IAC Motor-To-Throttle Body Bolts . . . . .	7 N·m (60 in. lbs.)
Intake Manifold Air Temp. Sensor—All Engines . . . . .	28 N·m (20 ft. lbs.)
MAP Sensor Mounting Screws—All Engines . . . . .	3 N·m (25 in. lbs.)
Oxygen Sensor—All Engines . . . . .	30 N·m (22 ft. lbs.)
Powertrain Control Module Mounting Screws . . . . .	3–5 N·m (30–40 in. lbs.)
Throttle Body Mounting Bolts . . . . .	23 N·m (200 in. lbs.)
Throttle Position Sensor Mounting Screws—All Engines . . . . .	7 N·m (60 in. lbs.)

**SPECIAL TOOLS**

**FUEL SYSTEM**



**Fitting, Air Metering—6714**

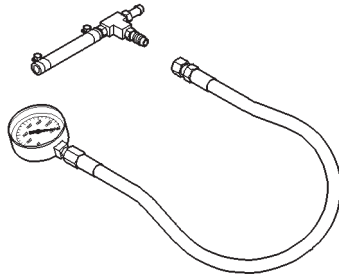


**Adapters, Fuel Pressure Test—6539 and/or 6631**

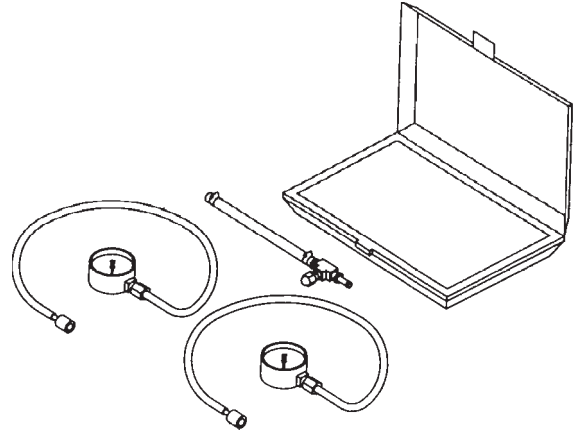
SPECIAL TOOLS (Continued)



**O2S (Oxygen Sensor) Remover/Installer—C-4907**



**Test Kit, Fuel Pressure—C-4799-B**



**Test Kit, Fuel Pressure—5069**



**Fuel Line Removal Tool—6782**

