

BRAKES

TABLE OF CONTENTS

	page		page
BASE BRAKE SYSTEM	1	FOUR WHEEL ANTILOCK BRAKES	40
REAR WHEEL ANTILOCK BRAKES	32		

BASE BRAKE SYSTEM

TABLE OF CONTENTS

	page		page
DESCRIPTION AND OPERATION			
BRAKE SYSTEM	2	BRAKE PEDAL	14
SERVICE WARNINGS & CAUTIONS	2	COMBINATION VALVE	14
BRAKE PEDAL	2	MASTER CYLINDER	15
STOP LAMP SWITCH	2	POWER BRAKE BOOSTER	15
RED BRAKE WARNING LAMP	3	DISC BRAKE CALIPER	16
POWER BRAKE BOOSTER	3	DISC BRAKE SHOES	17
MASTER CYLINDER	3	DISC BRAKE ROTOR	19
COMBINATION VALVE	3	REAR BRAKE SHOES	19
FRONT DISC BRAKES	4	WHEEL CYLINDER	21
DRUM BRAKES	4	BRAKE SUPPORT PLATE	21
PARKING BRAKES	5	FRONT PARK BRAKE CABLE	21
BRAKE HOSES AND LINES	5	REAR PARK BRAKE CABLES	22
		PARK BRAKE PEDAL ASSEMBLY	23
DIAGNOSIS AND TESTING			
BASE BRAKE SYSTEM	5	DISASSEMBLY AND ASSEMBLY	
BRAKE LAMP SWITCH	8	MASTER CYLINDER RESERVOIR	23
RED BRAKE WARNING LAMP	8	DISC BRAKE CALIPER	24
MASTER CYLINDER/POWER BOOSTER	8	WHEEL CYLINDER	27
COMBINATION VALVE	9	CLEANING AND INSPECTION	
DISC BRAKE ROTOR	9	REAR DRUM BRAKE	27
BRAKE DRUM	10	CALIPER	27
BRAKE LINE AND HOSES	10	WHEEL CYLINDER	28
BRAKE FLUID CONTAMINATION	10	ADJUSTMENTS	
SERVICE PROCEDURES			
BRAKE FLUID LEVEL	11	REAR DRUM BRAKE	28
MASTER CYLINDER BLEEDING	11	PARK BRAKE CABLE TENSIONER	30
BASE BRAKE BLEEDING	11	SPECIFICATIONS	
DISC ROTOR MACHINING	12	BRAKE FLUID	30
BRAKE DRUM MACHINING	12	BASE BRAKES	31
BRAKE TUBE FLARING	12	TORQUE CHART	31
REMOVAL AND INSTALLATION			
BRAKE LAMP SWITCH	13	SPECIAL TOOLS	
		BASE BRAKES	31

DESCRIPTION AND OPERATION

BRAKE SYSTEM

DESCRIPTION

This vehicle is equipped with front disc brakes and rear drum brakes. The front disc brakes consist of single piston calipers and ventilated rotors. The rear brakes are dual brake shoe, internal expanding units with cast brake drums. The parking brake mechanism is cable operated and connected to the rear brake secondary shoes. Power brake assist is standard equipment. A vacuum operated power brake booster is used for all applications.

Two antilock brake systems are used on this vehicle. A rear wheel antilock (RWAL) brake system is standard. An all-wheel antilock brake system (ABS) is available as an option.

SERVICE WARNINGS & CAUTIONS

DESCRIPTION

WARNING: DUST AND DIRT ACCUMULATING ON BRAKE PARTS DURING NORMAL USE MAY CONTAIN ASBESTOS FIBERS FROM PRODUCTION OR AFTERMARKET LININGS. BREATHING EXCESSIVE CONCENTRATIONS OF ASBESTOS FIBERS CAN CAUSE SERIOUS BODILY HARM. EXERCISE CARE WHEN SERVICING BRAKE PARTS. DO NOT CLEAN BRAKE PARTS WITH COMPRESSED AIR OR BY DRY BRUSHING. USE A VACUUM CLEANER SPECIFICALLY DESIGNED FOR THE REMOVAL OF ASBESTOS FIBERS FROM BRAKE COMPONENTS. IF A SUITABLE VACUUM CLEANER IS NOT AVAILABLE, CLEANING SHOULD BE DONE WITH A WATER DAMPENED CLOTH. DO NOT SAND, OR GRIND BRAKE LINING UNLESS EQUIPMENT USED IS DESIGNED TO CONTAIN THE DUST RESIDUE. DISPOSE OF ALL RESIDUE CONTAINING ASBESTOS FIBERS IN SEALED BAGS OR CONTAINERS TO MINIMIZE EXPOSURE TO YOURSELF AND OTHERS. FOLLOW PRACTICES PRESCRIBED BY THE OCCUPATIONAL SAFETY AND HEALTH ADMINISTRATION AND THE ENVIRONMENTAL PROTECTION AGENCY FOR THE HANDLING, PROCESSING, AND DISPOSITION OF DUST OR DEBRIS THAT MAY CONTAIN ASBESTOS FIBERS.

CAUTION: Never use gasoline, kerosene, alcohol, motor oil, transmission fluid, or any fluid containing mineral oil to clean the system components. These fluids damage rubber cups and seals. Use only fresh brake fluid or Mopar brake cleaner to clean or flush brake system components. These are the only

cleaning materials recommended. If system contamination is suspected, check the fluid for dirt, discoloration, or separation into distinct layers. Also check the reservoir cap seal for distortion. Drain and flush the system with new brake fluid if contamination is suspected.

CAUTION: Use Mopar brake fluid, or an equivalent quality fluid meeting SAE/DOT standards J1703 and DOT 3. Brake fluid must be clean and free of contaminants. Use fresh fluid from sealed containers only to ensure proper antilock component operation.

CAUTION: Use Mopar multi-mileage or high temperature grease to lubricate caliper slide surfaces, drum brake pivot pins, and shoe contact points on the backing plates. Use multi-mileage grease or GE 661 or Dow 111 silicone grease on caliper slide pins to ensure proper operation.

BRAKE PEDAL

DESCRIPTION

A suspended-type brake pedal is used. The pedal is attached to the pedal support bracket with a pivot pin and bushings. The booster push rod is attached to the pedal with a clip. The pedal, bushings, pivot pin and support bracket are all serviceable components.

OPERATION

The brake pedal is attached to the booster push rod. When the pedal is depressed, the primary booster push rod is depressed which move the booster secondary rod. The booster secondary rod depress the master cylinder piston.

STOP LAMP SWITCH

DESCRIPTION

The plunger type stop lamp switch is mounted on a bracket attached to the brake pedal support.

CAUTION: The switch can only be adjusted during initial installation. If the switch is not adjusted properly a new switch must be installed.

OPERATION

The brake lamp switch is used to for the brake lamp, speed control and brake sensor circuits. The brake lamp circuit is open until the plunger is

DESCRIPTION AND OPERATION (Continued)

depressed. The speed control and brake sensor circuits is closed until the plunger is depressed.

RED BRAKE WARNING LAMP**DESCRIPTION**

A red warning lamp is used for the service brake portion of the hydraulic system. The lamp is located in the instrument cluster.

OPERATION

The red warning light alerts the driver if a pressure differential exists between the front and rear hydraulic systems or the parking brakes are applied. The lamp is turned on momentarily when the ignition switch is turned to the on position. This is a self test to verify the lamp is operational.

POWER BRAKE BOOSTER**DESCRIPTION**

All models use a tandem diaphragm, power brake booster.

NOTE: The power brake booster is not a repairable component. The booster must be replaced as an assembly if diagnosis indicates a malfunction has occurred.

OPERATION

The booster unit consists of a single housing divided into two by a tandem diaphragm. The outer edge of the diaphragm is secured to the housing. The booster push rod, which connects the booster to the brake pedal and master cylinder, is attached to the center of the diaphragm. A check valve is used in the booster outlet connected to the engine intake manifold. Power assist is generated by utilizing a combination of vacuum and atmospheric pressure to boost brake assist.

MASTER CYLINDER**DESCRIPTION**

A two-piece master cylinder is used on all models. The cylinder body containing the primary and secondary pistons is made of aluminum. The removable fluid reservoir is made of nylon reinforced with glass fiber. The reservoir stores reserve brake fluid for the hydraulic brake circuits. The reservoir is the only serviceable component.

The fluid compartments of the nylon reservoir are interconnected to permit fluid level equalization. However, the equalization feature does not affect circuit separation in the event of a front or rear brake

malfunction. The reservoir compartments will retain enough fluid to operate the functioning hydraulic circuit.

Care must be exercised when removing/installing the master cylinder connecting lines. The threads in the cylinder fluid ports can be damaged if care is not exercised. Start all brake line fittings by hand to avoid cross threading.

The cylinder reservoir can be replaced when necessary. However, the aluminum body section of the master cylinder is not a repairable component.

NOTE: If diagnosis indicates that an internal malfunction has occurred, the aluminum body section must be replaced as an assembly.

OPERATION

The master cylinder bore contains a primary and secondary piston. The primary piston supplies hydraulic pressure to the front brakes. The secondary piston supplies hydraulic pressure to the rear brakes.

COMBINATION VALVE

The combination valve contains a pressure differential valve and switch and a proportioning valve. The combination valve/proportioning valve are not repairable and must be replaced as an assembly.

PRESSURE DIFFERENTIAL SWITCH

The pressure differential switch is connected to the brake warning lamp. The switch is triggered by movement of the switch valve. The purpose of the switch is to monitor fluid pressure in the separate front/rear brake hydraulic circuits.

A decrease or loss of fluid pressure in either hydraulic circuit will cause the switch valve to shuttle forward or rearward in response to the pressure differential. Movement of the switch valve will push the switch plunger upward. This closes the switch internal contacts completing the electrical circuit to the warning lamp. The switch valve may remain in an actuated position until repair restores system pressures to normal levels.

PROPORTIONING VALVE

The proportioning valve is used to balance front-rear brake action at high decelerations. The valve allows normal fluid pressure during moderate braking. The valve only controls fluid pressure during high decelerations brake stops, when a percentage of rear weight is transferred to the front wheels.

DESCRIPTION AND OPERATION (Continued)

FRONT DISC BRAKES

DESCRIPTION

The calipers are a single piston type. The calipers are free to slide laterally, this allows continuous compensation for lining wear.

OPERATION

When the brakes are applied fluid pressure is exerted against the caliper piston. The fluid pressure is exerted equally and in all directions. This means pressure exerted against the caliper piston and within the caliper bore will be equal (Fig. 1).

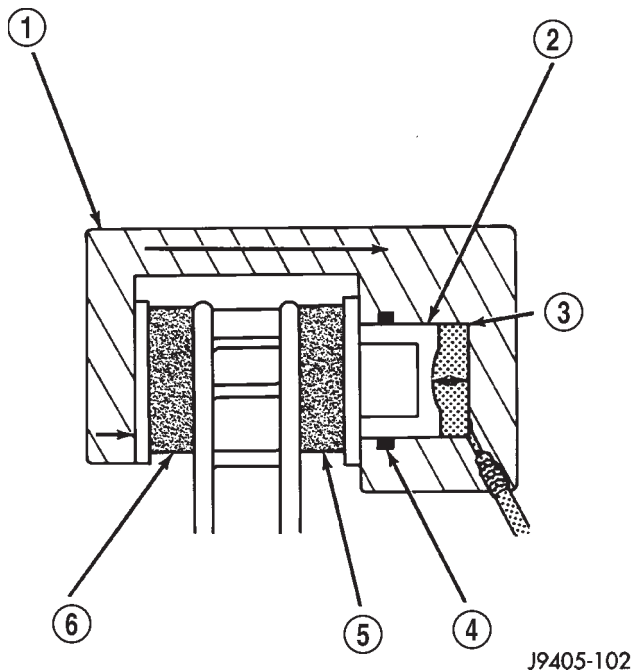

Fig. 1 Brake Caliper Operation

- 1 - CALIPER
- 2 - PISTON
- 3 - PISTON BORE
- 4 - SEAL
- 5 - INBOARD SHOE
- 6 - OUTBOARD SHOE

Fluid pressure applied to the piston is transmitted directly to the inboard brake shoe. This forces the shoe lining against the inner surface of the disc brake rotor. At the same time, fluid pressure within the piston bore forces the caliper to slide inward on the mounting bolts. This action brings the outboard brake shoe lining into contact with the outer surface of the disc brake rotor.

In summary, fluid pressure acting simultaneously on both piston and caliper, produces a strong clamping action. When sufficient force is applied, friction will attempt to stop the rotors from turning and bring the vehicle to a stop.

Application and release of the brake pedal generates only a very slight movement of the caliper and piston. Upon release of the pedal, the caliper and piston return to a rest position. The brake shoes do not retract an appreciable distance from the rotor. In fact, clearance is usually at, or close to zero. The reasons for this are to keep road debris from getting between the rotor and lining and in wiping the rotor surface clear each revolution.

The caliper piston seal controls the amount of piston extension needed to compensate for normal lining wear.

During brake application, the seal is deflected outward by fluid pressure and piston movement (Fig. 2). When the brakes (and fluid pressure) are released, the seal relaxes and retracts the piston.

The amount of piston retraction is determined by the amount of seal deflection. Generally the amount is just enough to maintain contact between the piston and inboard brake shoe.

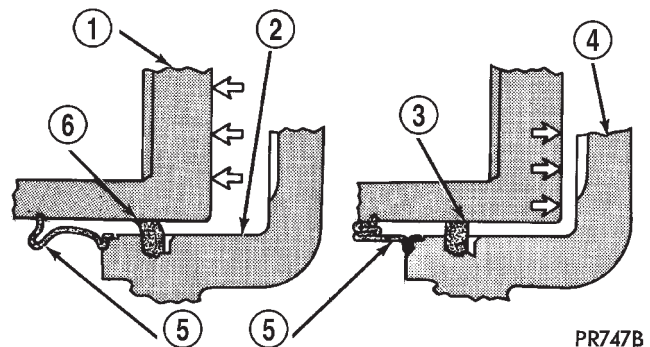

Fig. 2 Lining Wear Compensation By Piston Seal

- 1 - PISTON
- 2 - CYLINDER BORE
- 3 - PISTON SEAL BRAKE PRESSURE OFF
- 4 - CALIPER HOUSING
- 5 - DUST BOOT
- 6 - PISTON SEAL BRAKE PRESSURE ON

DRUM BRAKES

DESCRIPTION

Drum brakes on all models are dual shoe, internal expanding units with an automatic self adjusting mechanism (Fig. 3). Nine inch and eleven inch brakes are used.

OPERATION

When the brake pedal is depressed hydraulic pressure pushes the rear wheel cylinder pistons outward. The wheel cylinder push rods then push the brake shoes outward against the brake drum. When the brake pedal is released return springs attached to the brake shoes pull the shoes back to their original position.

DESCRIPTION AND OPERATION (Continued)

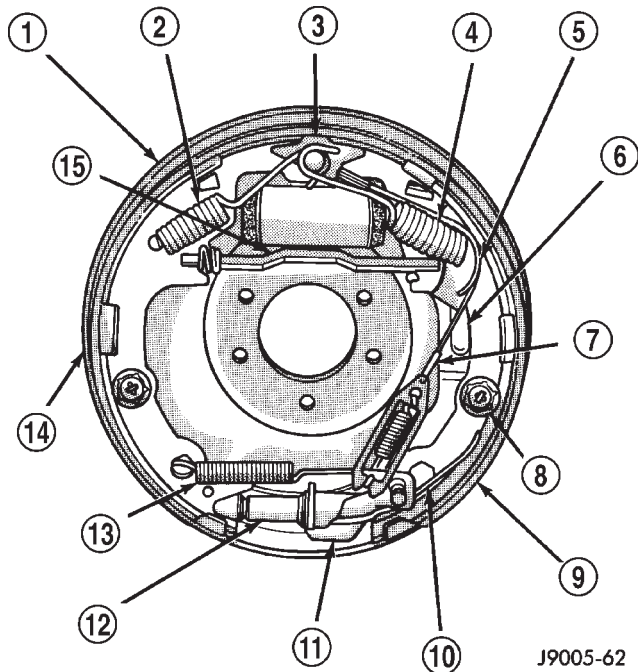

Fig. 3 Brake Assembly

- 1 - SUPPORT PLATE
- 2 - RETURN SPRING
- 3 - ANCHOR PLATE
- 4 - RETURN SPRING
- 5 - CABLE GUIDE
- 6 - PARKING BRAKE LEVER
- 7 - ADJUSTER CABLE AND SPRING
- 8 - SHOE RETAINER, SPRING AND PIN
- 9 - SECONDARY SHOE AND LINING
- 10 - LEVER SPRING
- 11 - ADJUSTER LEVER
- 12 - ADJUSTER SCREW ASSEMBLY
- 13 - SHOE SPRING
- 14 - PRIMARY SHOE AND LINING
- 15 - PARKING BRAKE STRUT AND SPRING

PARKING BRAKES

DESCRIPTION

The rear drum brake shoes serve as the parking brakes. The parking brakes are operated by a system of cables and levers attached to the rear brake secondary shoes.

OPERATION

The shoes make contact with the brake drum surface by a cable and lever mechanism attached to the secondary brake shoe. The front parking brake cable is connected to the parking brake pedal and to the rear cables. An intermediate cable is used on some vehicles to connect the front and rear cables.

The parking brake pedal assembly is mounted on the driver side cowl panel. The front cable is directly attached to the assembly. The pedal assembly con-

tains a spring loaded mechanism to hold the pedal in the applied position. A rod and spring are used to release the ratchet mechanism and return the pedal to normal position.

BRAKE HOSES AND LINES

DESCRIPTION

Flexible rubber hose is used at both front brakes and at the rear axle junction block. Double walled steel tubing is used to connect the master cylinder to the major hydraulic braking components and then to the flexible rubber hoses. Double inverted style and ISO style flares are used on the brake lines.

OPERATION

The hoses and lines transmit the brake fluid hydraulic pressure to the calipers and or wheel cylinders.

DIAGNOSIS AND TESTING

BASE BRAKE SYSTEM

Base brake components consist of the brake shoes, calipers, wheel cylinders, brake drums, rotors, brake lines, master cylinder, booster, and parking brake components.

Brake diagnosis involves determining if the problem is related to a mechanical, hydraulic, or vacuum operated component.

The first diagnosis step is the preliminary check.

PRELIMINARY BRAKE CHECK

(1) Check condition of tires and wheels. Damaged wheels and worn, damaged, or underinflated tires can cause pull, shudder, vibration, and a condition similar to grab.

(2) If complaint was based on noise when braking, check suspension components. Jounce front and rear of vehicle and listen for noise that might be caused by loose, worn or damaged suspension or steering components.

(3) Inspect brake fluid level and condition. Note that the brake reservoir fluid level will decrease in proportion to normal lining wear. **Also note that brake fluid tends to darken over time. This is normal and should not be mistaken for contamination.**

(a) If fluid level is abnormally low, look for evidence of leaks at calipers, wheel cylinders, brake lines, and master cylinder.

(b) If fluid appears contaminated, drain out a sample to examine. System will have to be flushed if fluid is separated into layers, or contains a substance other than brake fluid. The system seals

DIAGNOSIS AND TESTING (Continued)

and cups will also have to be replaced after flushing. Use clean brake fluid to flush the system.

(4) Check parking brake operation. Verify free movement and full release of cables and pedal. Also note if vehicle was being operated with parking brake partially applied.

(5) Check brake pedal operation. Verify that pedal does not bind and has adequate free play. If pedal lacks free play, check pedal and power booster for being loose or for bind condition. Do not road test until condition is corrected.

(6) Check booster vacuum check valve and hose.

(7) If components checked appear OK, road test the vehicle.

ROAD TESTING

(1) If complaint involved low brake pedal, pump pedal and note if it comes back up to normal height.

(2) Check brake pedal response with transmission in Neutral and engine running. Pedal should remain firm under constant foot pressure.

(3) During road test, make normal and firm brake stops in 25-40 mph range. Note faulty brake operation such as low pedal, hard pedal, fade, pedal pulsation, pull, grab, drag, noise, etc.

(4) Attempt to stop the vehicle with the parking brake only and note grab, drag, noise, etc.

PEDAL FALLS AWAY

A brake pedal that falls away under steady foot pressure is generally the result of a system leak. The leak point could be at a brake line, fitting, hose, or caliper/wheel cylinder. If leakage is severe, fluid will be evident at or around the leaking component.

Internal leakage (seal by-pass) in the master cylinder caused by worn or damaged piston cups, may also be the problem cause.

An internal leak in the ABS or RWAL system may also be the problem with no physical evidence.

LOW PEDAL

If a low pedal is experienced, pump the pedal several times. If the pedal comes back up worn linings, rotors, drums, or rear brakes out of adjustment are the most likely causes. The proper course of action is to inspect and replace all worn component and make the proper adjustments.

SPONGY PEDAL

A spongy pedal is most often caused by air in the system. However, thin brake drums or substandard brake lines and hoses can also cause a spongy pedal. The proper course of action is to bleed the system, and replace thin drums and substandard quality brake hoses if suspected.

HARD PEDAL OR HIGH PEDAL EFFORT

A hard pedal or high pedal effort may be due to lining that is water soaked, contaminated, glazed, or badly worn. The power booster or check valve could also be faulty.

PEDAL PULSATION

Pedal pulsation is caused by components that are loose, or beyond tolerance limits.

The primary cause of pulsation are disc brake rotors with excessive lateral runout or thickness variation, or out of round brake drums. Other causes are loose wheel bearings or calipers and worn, damaged tires.

NOTE: Some pedal pulsation may be felt during ABS activation.

BRAKE DRAG

Brake drag occurs when the lining is in constant contact with the rotor or drum. Drag can occur at one wheel, all wheels, fronts only, or rears only.

Drag is a product of incomplete brake shoe release. Drag can be minor or severe enough to overheat the linings, rotors and drums.

Minor drag will usually cause slight surface charring of the lining. It can also generate hard spots in rotors and drums from the overheat-cool down process. In most cases, the rotors, drums, wheels and tires are quite warm to the touch after the vehicle is stopped.

Severe drag can char the brake lining all the way through. It can also distort and score rotors and drums to the point of replacement. The wheels, tires and brake components will be extremely hot. In severe cases, the lining may generate smoke as it chars from overheating.

Common causes of brake drag are:

- Seized or improperly adjusted parking brake cables.
- Loose/worn wheel bearing.
- Seized caliper or wheel cylinder piston.
- Caliper binding on corroded bushings or rusted slide surfaces.
- Loose caliper mounting.
- Drum brake shoes binding on worn/damaged support plates.
- Mis-assembled components.
- Long booster output rod.

If brake drag occurs at all wheels, the problem may be related to a blocked master cylinder return port, or faulty power booster (binds-does not release).

DIAGNOSIS AND TESTING (Continued)

BRAKE FADE

Brake fade is usually a product of overheating caused by brake drag. However, brake overheating and resulting fade can also be caused by riding the brake pedal, making repeated high deceleration stops in a short time span, or constant braking on steep mountain roads. Refer to the Brake Drag information in this section for causes.

BRAKE PULL

Front brake pull condition could result from:

- Contaminated lining in one caliper
- Seized caliper piston
- Binding caliper
- Loose caliper
- Rusty caliper slide surfaces
- Improper brake shoes
- Damaged rotor

A worn, damaged wheel bearing or suspension component are further causes of pull. A damaged front tire (bruised, ply separation) can also cause pull.

A common and frequently misdiagnosed pull condition is where direction of pull changes after a few stops. The cause is a combination of brake drag followed by fade at one of the brake units.

As the dragging brake overheats, efficiency is so reduced that fade occurs. Since the opposite brake unit is still functioning normally, its braking effect is magnified. This causes pull to switch direction in favor of the normally functioning brake unit.

An additional point when diagnosing a change in pull condition concerns brake cool down. Remember that pull will return to the original direction, if the dragging brake unit is allowed to cool down (and is not seriously damaged).

REAR BRAKE GRAB OR PULL

Rear grab or pull is usually caused by improperly adjusted or seized parking brake cables, contaminated lining, bent or binding shoes and support plates, or improperly assembled components. This is particularly true when only one rear wheel is involved. However, when both rear wheels are affected, the master cylinder or proportioning valve could be at fault.

BRAKES DO NOT HOLD AFTER DRIVING THROUGH DEEP WATER PUDDLES

This condition is generally caused by water soaked lining. If the lining is only wet, it can be dried by driving with the brakes very lightly applied for a mile or two. However, if the lining is both soaked and dirt contaminated, cleaning and/or replacement will be necessary.

BRAKE LINING CONTAMINATION

Brake lining contamination is mostly a product of leaking calipers or wheel cylinders, worn seals, driving through deep water puddles, or lining that has become covered with grease and grit during repair. Contaminated lining should be replaced to avoid further brake problems.

WHEEL AND TIRE PROBLEMS

Some conditions attributed to brake components may actually be caused by a wheel or tire problem.

A damaged wheel can cause shudder, vibration and pull. A worn or damaged tire can also cause pull.

Severely worn tires with very little tread left can produce a grab-like condition as the tire loses and recovers traction. Flat-spotted tires can cause vibration and generate shudder during brake operation. A tire with internal damage such as a severe bruise, cut, or ply separation can cause pull and vibration.

BRAKE NOISES

Some brake noise is common with rear drum brakes and on some disc brakes during the first few stops after a vehicle has been parked overnight or stored. This is primarily due to the formation of trace corrosion (light rust) on metal surfaces. This light corrosion is typically cleared from the metal surfaces after a few brake applications causing the noise to subside.

BRAKE SQUEAK/SQUEAL

Brake squeak or squeal may be due to linings that are wet or contaminated with brake fluid, grease, or oil. Glazed linings and rotors with hard spots can also contribute to squeak. Dirt and foreign material embedded in the brake lining will also cause squeak/squeal.

A very loud squeak or squeal is frequently a sign of severely worn brake lining. If the lining has worn through to the brake shoes in spots, metal-to-metal contact occurs. If the condition is allowed to continue, rotors and drums can become so scored that replacement is necessary.

BRAKE CHATTER

Brake chatter is usually caused by loose or worn components, or glazed/burnt lining. Rotors with hard spots can also contribute to chatter. Additional causes of chatter are out-of-tolerance rotors, brake lining not securely attached to the shoes, loose wheel bearings and contaminated brake lining.

THUMP/CLUNK NOISE

Thumping or clunk noises during braking are frequently **not** caused by brake components. In many cases, such noises are caused by loose or damaged

DIAGNOSIS AND TESTING (Continued)

steering, suspension, or engine components. However, calipers that bind on the slide surfaces can generate a thump or clunk noise. In addition, worn out, improperly adjusted, or improperly assembled rear brake shoes can also produce a thump noise.

BRAKE LAMP SWITCH

The brake lamp switch can be tested with an ohmmeter. The ohmmeter is used to check continuity between the pin terminals (Fig. 4).

SWITCH CIRCUIT IDENTIFICATION

- Terminals 1 and 2: brake lamp circuit
- Terminals 3 and 4: RWAL/ABS module and Powertrain Control Module (PCM) circuit
- Terminals 5 and 6: speed control circuit

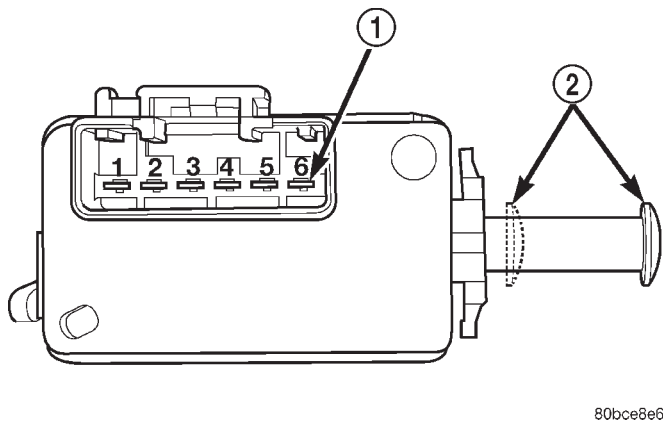

Fig. 4 Brake Lamp Switch Terminal Identification

- 1 - TERMINAL PINS
2 - PLUNGER TEST POSITIONS

SWITCH CONTINUITY TEST

NOTE: Disconnect switch harness before testing switch continuity.

With switch plunger extended, attach test leads to pins 1 and 2. Replace switch if meter indicates no continuity.

With switch plunger retracted, attach test leads to pins 3 and 4. Replace switch if meter indicates no continuity.

With switch plunger retracted, attach test leads to pins 5 and 6. Replace switch if meter indicates no continuity.

RED BRAKE WARNING LAMP

The red warning lamp is in circuit with the parking brake switch and pressure differential switch in the combination valve.

The red lamp illuminates when the parking brakes are applied, or when a pressure drop occurs in the front or rear brake hydraulic circuit.

The lamp illuminates for approximately 2-4 seconds at every engine start up. This is a self test feature designed to check bulb and circuit operation.

A pressure drop in the front or rear brake hydraulic circuit activates the pressure differential valve inside the combination valve. A pressure decrease moves the valve toward the low pressure side. As the valve moves, it pushes the pressure differential switch contact plunger upward. This closes the switch internal contacts and completes the circuit to the red warning lamp. The lamp will remain on until repairs are made and normal fluid pressure restored.

MASTER CYLINDER/POWER BOOSTER

(1) Start engine and check booster vacuum hose connections. A hissing noise indicates vacuum leak. Correct any vacuum leak before proceeding.

(2) Stop engine and shift transmission into Neutral.

(3) Pump brake pedal until all vacuum reserve in booster is depleted.

(4) Press and hold brake pedal under light foot pressure. The pedal should hold firm, if the pedal falls away master cylinder is faulty (internal leakage).

(5) Start engine and note pedal action. It should fall away slightly under light foot pressure then hold firm. If no pedal action is discernible, power booster, vacuum supply, or vacuum check valve is faulty. Proceed to the POWER BOOSTER VACUUM TEST.

(6) If the POWER BOOSTER VACUUM TEST passes, rebuild booster vacuum reserve as follows: Release brake pedal. Increase engine speed to 1500 rpm, close the throttle and immediately turn off ignition to stop engine.

(7) Wait a minimum of 90 seconds and try brake action again. Booster should provide two or more vacuum assisted pedal applications. If vacuum assist is not provided, booster is faulty.

POWER BOOSTER VACUUM TEST

(1) Connect vacuum gauge to booster check valve with short length of hose and T-fitting (Fig. 5).

(2) Start and run engine at curb idle speed for one minute.

(3) Observe the vacuum supply. If vacuum supply is not adequate, repair vacuum supply.

(4) Clamp hose shut between vacuum source and check valve.

(5) Stop engine and observe vacuum gauge.

(6) If vacuum drops more than one inch HG (33 millibars) within 15 seconds, booster diaphragm or check valve is faulty.

POWER BOOSTER CHECK VALVE TEST

(1) Disconnect vacuum hose from check valve.

DIAGNOSIS AND TESTING (Continued)

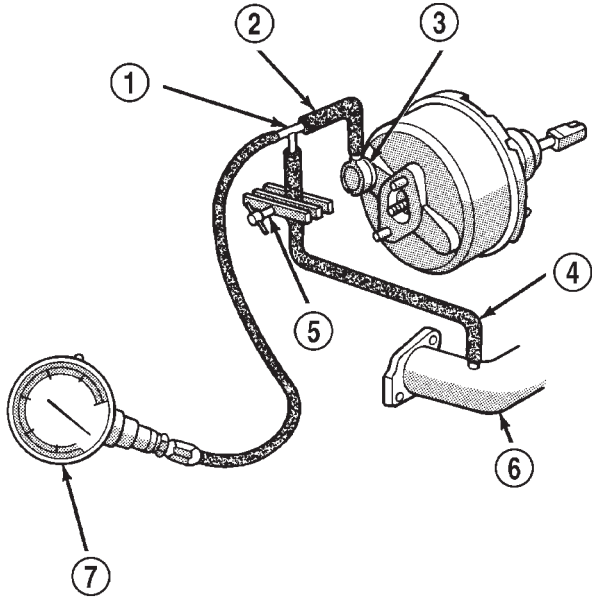

J9005-81

Fig. 5 Typical Booster Vacuum Test Connections

- 1 - TEE FITTING
- 2 - SHORT CONNECTING HOSE
- 3 - CHECK VALVE
- 4 - CHECK VALVE HOSE
- 5 - CLAMP TOOL
- 6 - INTAKE MANIFOLD
- 7 - VACUUM GAUGE

(2) Remove check valve and valve seal from booster.

(3) Use a hand operated vacuum pump for test.

(4) Apply 15-20 inches vacuum at large end of check valve (Fig. 6).

(5) Vacuum should hold steady. If gauge on pump indicates vacuum loss, check valve is faulty and should be replaced.

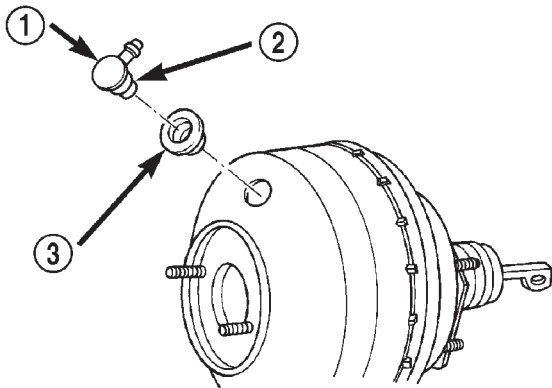

8031e866

Fig. 6 Vacuum Check Valve And Seal

- 1 - BOOSTER CHECK VALVE
- 2 - APPLY TEST VACUUM HERE
- 3 - VALVE SEAL

COMBINATION VALVE

Pressure Differential Switch

(1) Have helper sit in drivers seat to apply brake pedal and observe red brake warning light.

(2) Raise vehicle on hoist.

(3) Connect bleed hose to a rear wheel cylinder and immerse hose end in container partially filled with brake fluid.

(4) Have helper press and hold brake pedal to floor and observe warning light.

(a) If warning light illuminates, switch is operating correctly.

(b) If light fails to illuminate, check circuit fuse, bulb, and wiring. The parking brake switch can be used to aid in identifying whether or not the brake light bulb and fuse is functional. Repair or replace parts as necessary and test differential pressure switch operation again.

(5) If warning light still does not illuminate, switch is faulty. Replace combination valve assembly, bleed brake system and verify proper switch and valve operation.

DISC BRAKE ROTOR

The rotor braking surfaces should not be refinished unless necessary.

Light surface rust and scale can be removed with a lathe equipped with dual sanding discs. The rotor surfaces can be restored by machining in a disc brake lathe if surface scoring and wear are light.

Replace the rotor under the following conditions:

- severely scored
- tapered
- hard spots
- cracked
- below minimum thickness

ROTOR MINIMUM THICKNESS

Measure rotor thickness at the center of the brake shoe contact surface. Replace the rotor if worn below minimum thickness, or if machining would reduce thickness below the allowable minimum.

Rotor minimum thickness is usually specified on the rotor hub. The specification is either stamped or cast into the hub surface.

ROTOR RUNOUT

Check rotor lateral runout with dial indicator C-3339 (Fig. 7). Excessive lateral runout will cause brake pedal pulsation and rapid, uneven wear of the brake shoes. Position the dial indicator plunger approximately 25.4 mm (1 in.) inward from the rotor edge. Maximum allowable rotor runout is 0.102 mm (0.004 in.).

DIAGNOSIS AND TESTING (Continued)

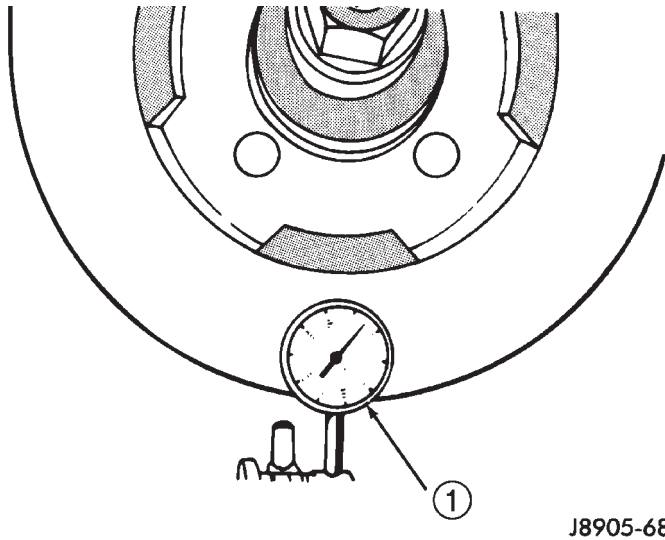

Fig. 7 Checking Rotor Runout And Thickness Variation

1 - DIAL INDICATOR

ROTOR THICKNESS VARIATION

Variations in rotor thickness will cause pedal pulsation, noise and shudder.

Measure rotor thickness at 6 to 12 points around the rotor face (Fig. 8).

Position the micrometer approximately 25.4 mm (1 in.) from the rotor outer circumference for each measurement.

Thickness should not **vary** by more than 0.013 mm (0.0005 in.) from point-to-point on the rotor. Machine or replace the rotor if necessary.

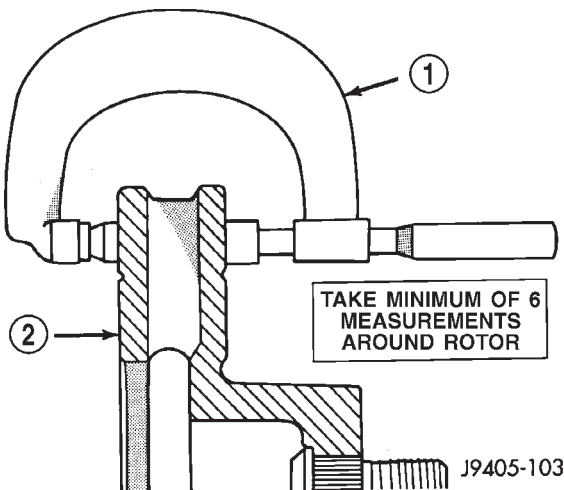

Fig. 8 Measuring Rotor Thickness

1 - MICROMETER

2 - ROTOR

BRAKE DRUM

The maximum allowable diameter of the drum braking surface is indicated on the drum outer edge. Generally, a drum can be machined to a maximum of 1.52 mm (0.060 in.) oversize. Always replace the drum if machining would cause drum diameter to exceed the size limit indicated on the drum.

BRAKE DRUM RUNOUT

Measure drum diameter and runout with an accurate gauge. The most accurate method of measurement involves mounting the drum in a brake lathe and checking variation and runout with a dial indicator.

Variations in drum diameter should not exceed 0.069 mm (0.0028 in.). Drum runout should not exceed 0.18 mm (0.007 in.) out of round. Machine the drum if runout or variation exceed these values. Replace the drum if machining causes the drum to exceed the maximum allowable diameter.

BRAKE LINE AND HOSES

Flexible rubber hose is used at both front brakes and at the rear axle junction block. Inspect the hoses whenever the brake system is serviced, at every engine oil change, or whenever the vehicle is in for service.

Inspect the hoses for surface cracking, scuffing, or worn spots. Replace any brake hose immediately if the fabric casing of the hose is exposed due to cracks or abrasions.

Also check brake hose installation. Faulty installation can result in kinked, twisted hoses, or contact with the wheels and tires or other chassis components. All of these conditions can lead to scuffing, cracking and eventual failure.

The steel brake lines should be inspected periodically for evidence of corrosion, twists, kinks, leaks, or other damage. Heavily corroded lines will eventually rust through causing leaks. In any case, corroded or damaged brake lines should be replaced.

Factory replacement brake lines and hoses are recommended to ensure quality, correct length and superior fatigue life. Care should be taken to make sure that brake line and hose mating surfaces are clean and free from nicks and burrs. Also remember that right and left brake hoses are not interchangeable.

Use new copper seal washers at all caliper connections. Be sure brake line connections are properly made (not cross threaded) and tightened to recommended torque.

BRAKE FLUID CONTAMINATION

Indications of fluid contamination are swollen or deteriorated rubber parts.

DIAGNOSIS AND TESTING (Continued)

Swollen rubber parts indicate the presence of petroleum in the brake fluid.

To test for contamination, put a small amount of drained brake fluid in clear glass jar. If fluid separates into layers, there is mineral oil or other fluid contamination of the brake fluid.

If brake fluid is contaminated, drain and thoroughly flush system. Replace master cylinder, proportioning valve, caliper seals, wheel cylinder seals, Antilock Brakes hydraulic unit and all hydraulic fluid hoses.

SERVICE PROCEDURES

BRAKE FLUID LEVEL

Always clean the master cylinder reservoir and caps before checking fluid level. If not cleaned, dirt could enter the fluid.

The fluid fill level is indicated on the side of the master cylinder reservoir (Fig. 9).

The correct fluid level is to the FULL indicator on the side of the reservoir. If necessary, add fluid to the proper level.

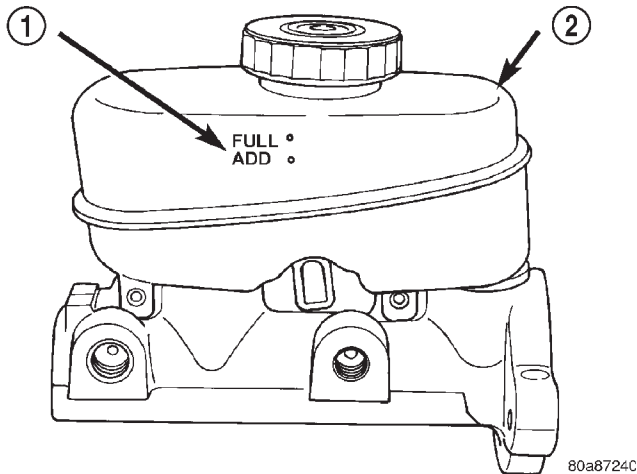

Fig. 9 Master Cylinder Fluid Level - Typical

- 1 - INDICATOR
- 2 - RESERVOIR

MASTER CYLINDER BLEEDING

A new master cylinder should be bled before installation on the vehicle. Required bleeding tools include bleed tubes and a wood dowel to stroke the pistons. Bleed tubes can be fabricated from brake line.

BLEEDING PROCEDURE

- (1) Mount master cylinder in vise.
- (2) Attach bleed tubes to cylinder outlet ports. Then position each tube end into the reservoir (Fig. 10).
- (3) Fill reservoir with fresh brake fluid.

(4) Press cylinder pistons inward with wood dowel. Then release pistons and allow them to return under spring pressure. Continue bleeding operations until air bubbles are no longer visible in fluid.

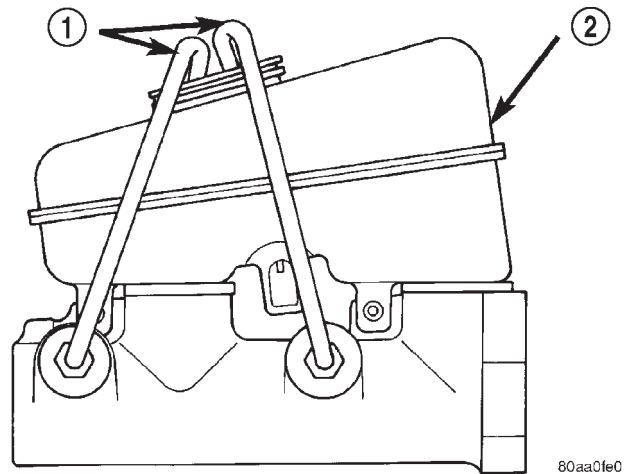

Fig. 10 Master Cylinder Bleeding

- 1 - BLEEDING TUBES
- 2 - RESERVOIR

BASE BRAKE BLEEDING

Use Mopar brake fluid, or an equivalent quality fluid meeting SAE J1703-F and DOT 3 standards only. Use fresh, clean fluid from a sealed container at all times.

Do not pump the brake pedal at any time while bleeding. Air in the system will be compressed into small bubbles that are distributed throughout the hydraulic system. This will make additional bleeding operations necessary.

Do not allow the master cylinder to run out of fluid during bleed operations. An empty cylinder will allow additional air to be drawn into the system. Check the cylinder fluid level frequently and add fluid as needed.

Bleed only one brake component at a time in the following sequence:

- Master Cylinder
- Combination Valve
- Rear Antilock Valve
- Right Rear Wheel
- Left Rear Wheel
- Right Front Wheel
- Left Front Wheel

MANUAL BLEEDING

- (1) Remove reservoir filler caps and fill reservoir.
- (2) If calipers, or wheel cylinders were overhauled, open all caliper and wheel cylinder bleed screws. Then close each bleed screw as fluid starts to drip from it. Top off master cylinder reservoir once more before proceeding.

SERVICE PROCEDURES (Continued)

(3) Attach one end of bleed hose to bleed screw and insert opposite end in glass container partially filled with brake fluid (Fig. 11). Be sure end of bleed hose is immersed in fluid.

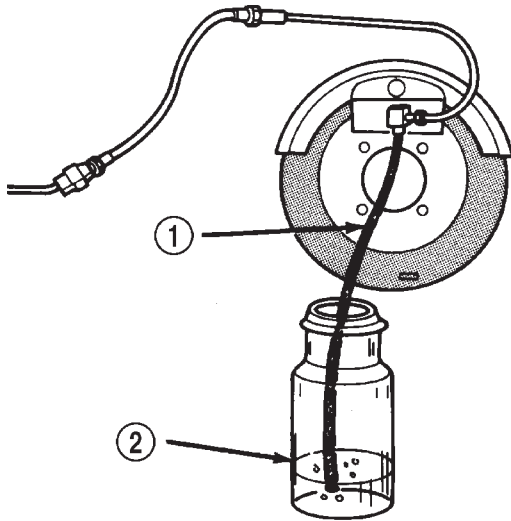

J8905-18

Fig. 11 Bleed Hose Setup

- 1 - BLEED HOSE
2 - FLUID CONTAINER PARTIALLY FILLED WITH FLUID

(4) Open up bleeder, then have a helper press down the brake pedal. Once the pedal is down close the bleeder. Repeat bleeding until fluid stream is clear and free of bubbles. Then move to the next wheel.

PRESSURE BLEEDING

Follow the manufacturers instructions carefully when using pressure equipment. Do not exceed the tank manufacturers pressure recommendations. Generally, a tank pressure of 15-20 psi is sufficient for bleeding.

Fill the bleeder tank with recommended fluid and purge air from the tank lines before bleeding.

Do not pressure bleed without a proper master cylinder adapter. The wrong adapter can lead to leakage, or drawing air back into the system. Use adapter provided with the equipment or Adapter 6921.

DISC ROTOR MACHINING

The disc brake rotor can be machined if scored or worn. The lathe must machine both sides of the rotor simultaneously with dual cutter heads. The rotor mounting surface must be clean before placing on the lathe. Equipment capable of machining only one side at a time may produce a tapered rotor.

NOTE: A hub mounted on-vehicle lathe is recommended. This type of lathe trues the rotor to the vehicles hub/bearing.

CAUTION: Brake rotors that do not meet minimum thickness specifications before or after machining must be replaced.

BRAKE DRUM MACHINING

The brake drums can be machined on a drum lathe when necessary. Initial machining cuts should be limited to 0.12 - 0.20 mm (0.005 - 0.008 in.) at a time as heavier feed rates can produce taper and surface variation. Final finish cuts of 0.025 to 0.038 mm (0.001 to 0.0015 in.) are recommended and will generally provide the best surface finish.

Be sure the drum is securely mounted in the lathe before machining operations. A damper strap should always be used around the drum to reduce vibration and avoid chatter marks.

The maximum allowable diameter of the drum braking surface is stamped or cast into the drum outer edge.

CAUTION: Replace the drum if machining will cause the drum to exceed the maximum allowable diameter.

BRAKE TUBE FLARING

A preformed metal brake tube is recommended and preferred for all repairs. However, double-wall steel tube can be used for emergency repair when factory replacement parts are not readily available.

Special bending tools are needed to avoid kinking or twisting of metal brake tubes. Special flaring tools are needed to make a double inverted flare or ISO flare (Fig. 12).

DOUBLE INVERTED FLARING

- (1) Cut off damaged tube with Tubing Cutter.
- (2) Ream cut edges of tubing to ensure proper flare.
- (3) Install replacement tube nut on the tube.
- (4) Insert tube in flaring tool.
- (5) Place gauge form over the end of the tube.
- (6) Push tubing through flaring tool jaws until tube contacts recessed notch in gauge that matches tube diameter.
- (7) Tighten the tool bar on the tube
- (8) Insert plug on gauge in the tube. Then swing compression disc over gauge and center tapered flaring screw in recess of compression disc (Fig. 13).

SERVICE PROCEDURES (Continued)

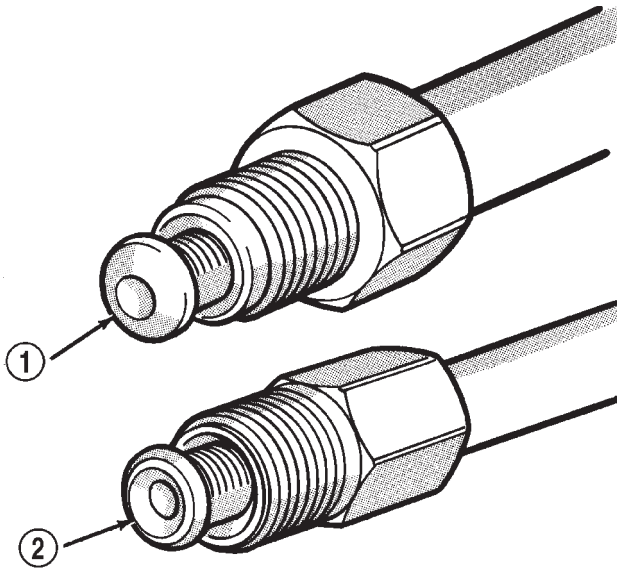

9205-174

Fig. 12 Inverted Flare And ISO Flare

- 1 - ISO-STYLE FLARE
- 2 - DOUBLE INVERTED-STYLE FLARE

(9) Tighten tool handle until plug gauge is squarely seated on jaws of flaring tool. This will start the inverted flare.

(10) Remove the plug gauge and complete the inverted flare.

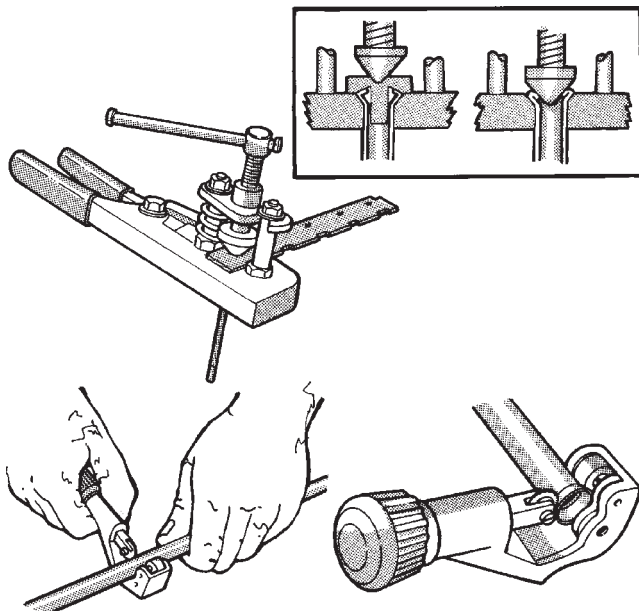

RH222

Fig. 13 Inverted Flare Tools

ISO FLARING

To make a ISO flare use Snap-On® Flaring Tool TFM-428 or equivalent.

- (1) Cut off damaged tube with Tubing Cutter.

- (2) Remove any burrs from the inside of the tube.
- (3) Install tube nut on the tube.
- (4) Position the tube in the flaring tool flush with the top of the tool bar (Fig. 14). Then tighten the tool bar on the tube.
- (5) Install the correct size adaptor on the flaring tool yoke screw.
- (6) Lubricate the adaptor.
- (7) Align the adaptor and yoke screw over the tube (Fig. 14).
- (8) Turn the yoke screw in until the adaptor is squarely seated on the tool bar.

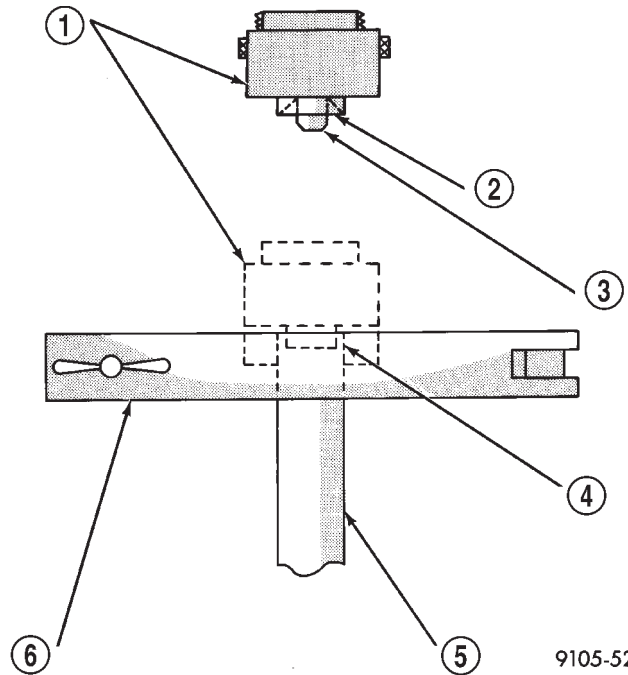

9105-52

Fig. 14 ISO Flaring

- 1 - ADAPTER
- 2 - LUBRICATE HERE
- 3 - PILOT
- 4 - FLUSH WITH BAR
- 5 - TUBING
- 6 - BAR ASSEMBLY

REMOVAL AND INSTALLATION

BRAKE LAMP SWITCH

REMOVAL

- (1) Disconnect switch harness (Fig. 15).
- (2) Press and hold brake pedal in applied position.
- (3) Rotate switch counterclockwise about 30° to align switch lock tab with notch in bracket.
- (4) Pull switch rearward out of mounting bracket and release brake pedal.

INSTALLATION

- (1) Press and hold brake pedal down.

REMOVAL AND INSTALLATION (Continued)

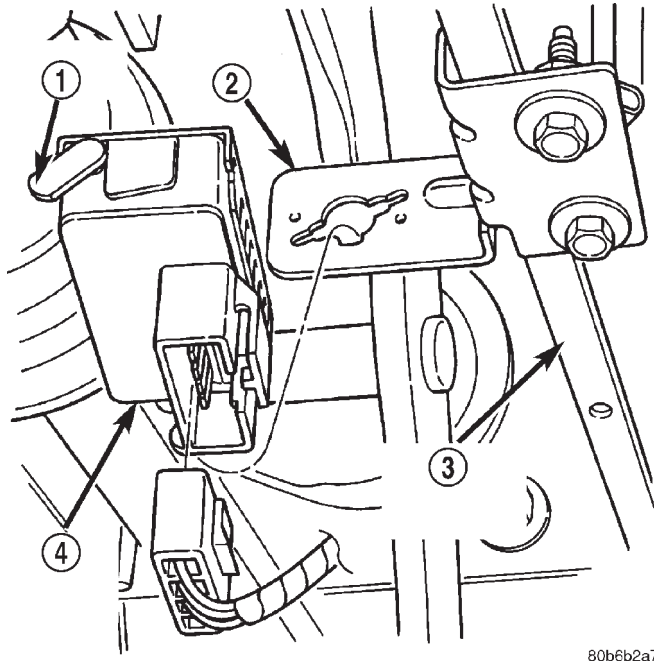

80b6b2a7

Fig. 15 Brake Lamp Switch & Bracket

- 1 - RELEASE LEVER
- 2 - BRACKET
- 3 - BRAKE PEDAL SUPPORT
- 4 - BRAKE LAMP SWITCH

(2) Align tab on **new** switch with notch in switch bracket. Then insert switch in bracket and turn it clockwise about 30° to lock it in place.

(3) Connect harness wires to switch.

(4) Release brake pedal.

(5) Move the release lever (Fig. 15) on the switch to engage the switch plunger. The switch is now adjusted and **can not** be adjusted again.

BRAKE PEDAL**REMOVAL**

- (1) Remove stop lamp switch.
- (2) Remove clip securing booster push rod to brake pedal (Fig. 16).
- (3) Remove pedal pivot pin C-clip and slide pin out of support bracket and pedal.
- (4) Remove pedal and bushings.

INSTALLATION

- (1) Replace bushings if worn or damaged.
- (2) Lubricate pedal bushings and pivot pin with Mopar multi mileage grease, Lubriplate, or a silicone grease.
- (3) Install bushings in pedal and position pedal in support.
- (4) Insert pivot pin through support and pedal bushings and install C-clip.

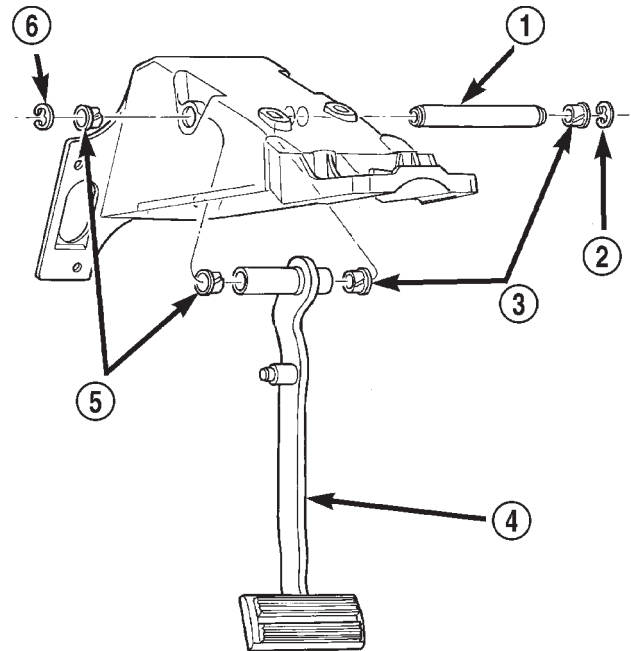

80b1b3d0

Fig. 16 Brake Pedal Mounting

- 1 - PIVOT PIN
- 2 - CLIP
- 3 - BUSHINGS
- 4 - BRAKE PEDAL
- 5 - BUSHINGS
- 6 - CLIP

(5) Install booster push rod on brake pedal and install push rod retainer clip.

(6) Install stop lamp switch.

COMBINATION VALVE**REMOVAL**

- (1) Disconnect wire from the pressure differential switch.
- (2) Disconnect rear brake lines from combination valve.
- (3) Remove the bolt from the combination valve and remove the valve.

INSTALLATION

- (1) Install the combination valve to the bracket and tighten the mounting bolt to 20-27 N·m (15-20 ft. lbs.). If vehicle is equipped with ABS brakes tighten the bolt to 10-13 N·m (7-10 ft. lbs.).
- (2) Install the brake lines to the combination valve.
- (3) Tighten the brake line to 19 N·m (170 in. lbs.).
- (4) Connect the wire to the pressure differential switch.
- (5) Bleed brakes system.

REMOVAL AND INSTALLATION (Continued)

MASTER CYLINDER

REMOVAL

- (1) Remove brake lines from the master cylinder (Fig. 17).
- (2) Remove mounting nuts from the master cylinder (Fig. 17).
- (3) Remove master cylinder.

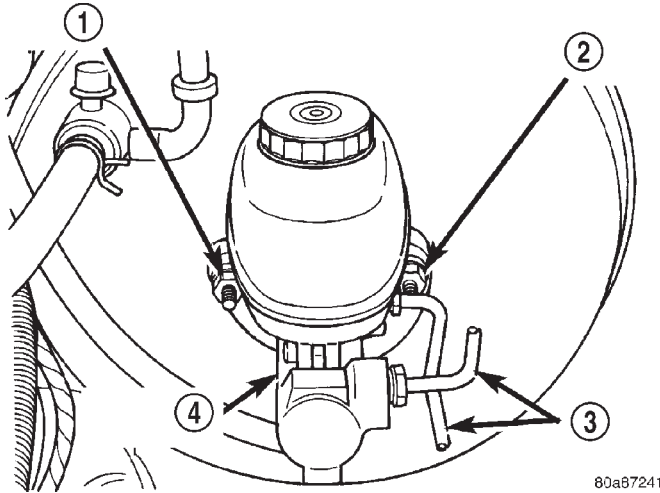

Fig. 17 Master Cylinder

- 1 - MOUNTING NUT
- 2 - MOUNTING NUT
- 3 - BRAKE LINES
- 4 - MASTER CYLINDER

INSTALLATION

NOTE: If master cylinder is replaced bleed cylinder before installation.

- (1) Install master cylinder on booster mounting studs.
- (2) Install mounting nuts and tighten to 18 N·m (160 in. lbs.)
- (3) Install brake lines and tighten to 19 N·m (170 in. lbs.)
- (4) Fill and bleed base brake system.

POWER BRAKE BOOSTER

REMOVAL

- (1) Remove master cylinder.
- (2) Disconnect vacuum lines at booster.
- (3) Remove clip securing booster push rod to brake pedal (Fig. 18).
- (4) Remove nuts from booster mounting studs (Fig. 19).
- (5) Remove booster, spacer and gaskets from front cowl panel.

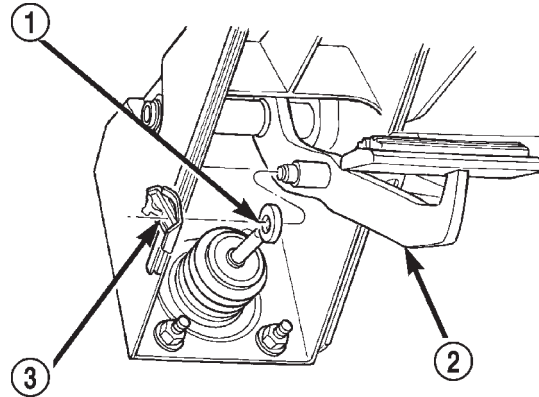

80b1b3ce

Fig. 18 Booster Rod Clip

- 1 - BOOSTER ROD
- 2 - BRAKE PEDAL
- 3 - CLIP

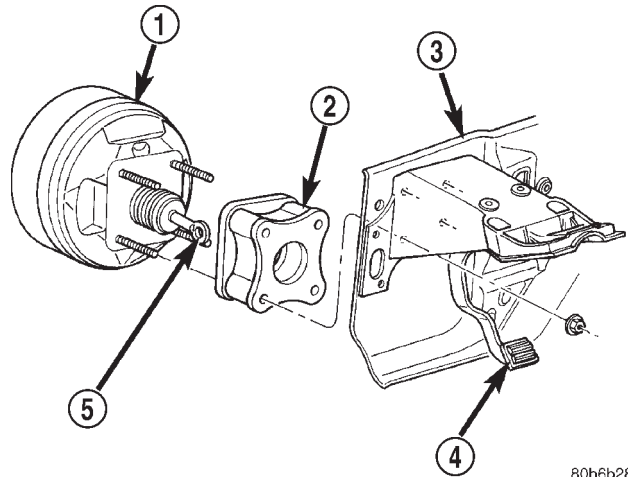

80b6b283

Fig. 19 Power Brake Booster Mounting

- 1 - BRAKE BOOSTER
- 2 - SPACER
- 3 - FRONT COWL PANEL
- 4 - BRAKE PEDAL
- 5 - BRAKE BOOSTER ROD

INSTALLATION

- (1) Position spacer and gaskets on booster studs.
- (2) Guide booster studs into cowl panel holes and seat booster on panel.
- (3) Install and tighten booster attaching nuts to 28 N·m (250 in. lbs.).
- (4) Install booster push rod on brake pedal and install clip.
- (5) Install booster check valve if removed and connect vacuum hose to check valve.
- (6) Install master cylinder.
- (7) Fill and bleed brake system.

REMOVAL AND INSTALLATION (Continued)

DISC BRAKE CALIPER

REMOVAL

- (1) Clean master cylinder reservoir and filler caps.
- (2) Remove reservoir filler cap and drain approximately 1/4 of fluid from reservoir. Use clean suction gun or similar device to drain fluid.
- (3) Raise and support vehicle.
- (4) Remove front wheel and tire assemblies.
- (5) Bottom caliper pistons in bores with large C-clamp. Position clamp frame on rear of caliper and clamp screw on outboard brake shoe.
- (6) Disconnect brake hose at caliper. Discard hose fitting washers if worn, or damaged (Fig. 20).

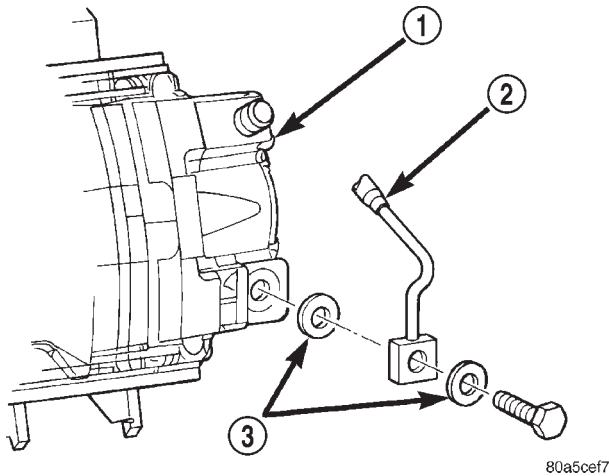
**Fig. 20 Caliper Brake Hose Connection**

- 1 - CALIPER
- 2 - FRONT BRAKE HOSE
- 3 - FITTING WASHERS

- (7) With a screw driver pry up on the caliper spring and pull the spring out of the caliper holes.
- (8) Remove caliper and brake shoes from caliper.

INSTALLATION

- (1) Install brake shoes in caliper.
- (2) Install caliper and shoes over rotor and into ledges in steering knuckle. Be sure ends of brake shoes are properly seated on slide surfaces of ledges.
- (3) Install and tighten caliper slide pins to 30 N·m (22 ft. lbs.). **Start the slide pins by hand before tightening. Do not cross thread the pins.**
- (4) Install caliper spring into one caliper hole and under the adapter. Pull down on the opposite end of the spring (Fig. 21) and hold the end under the adapter. With a screw driver pry up on the spring (Fig. 22) to seat the spring into the other caliper hole.

NOTE: Verify the spring is seated properly into the caliper holes.

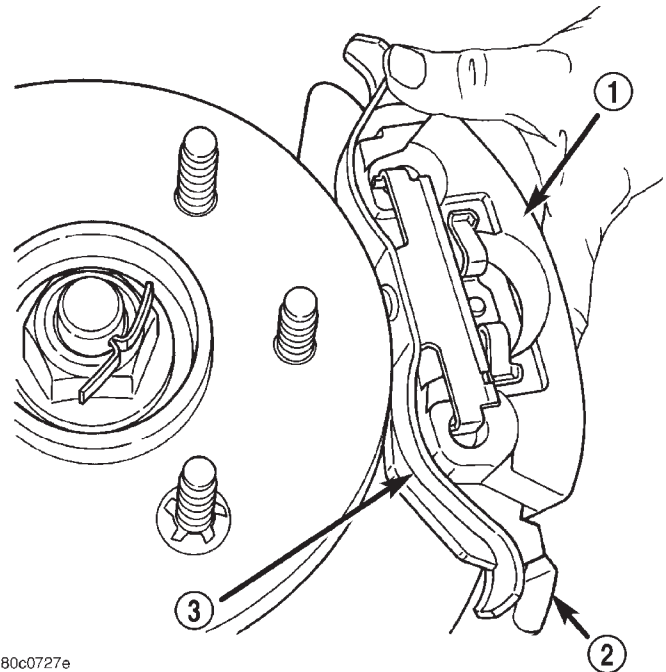

80c0727e

Fig. 21 Caliper Spring

- 1 - CALIPER
- 2 - ADAPTER
- 3 - CALIPER SPRING

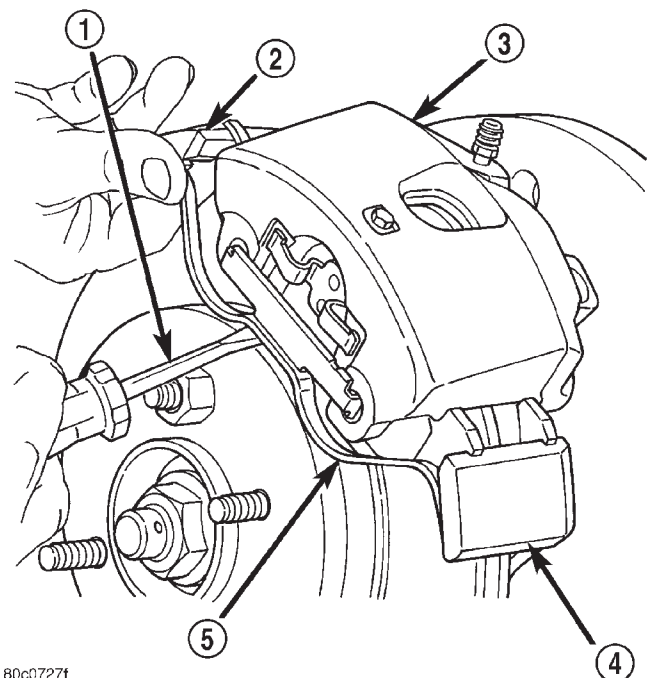

80c0727f

Fig. 22 Seat Caliper Spring

- 1 - SCREWDRIVER
- 2 - ADAPTER
- 3 - CALIPER
- 4 - ADAPTER
- 5 - CALIPER SPRING

REMOVAL AND INSTALLATION (Continued)

(5) Install brake hose to caliper with **new seal washers** and tighten fitting bolt to 24 N-m (18 ft. lbs.).

CAUTION: Verify brake hose is not twisted or kinked before tightening fitting bolt.

- (6) Bleed base brake system.
- (7) Install wheel and tire assemblies.
- (8) Remove supports and lower vehicle.
- (9) Pump brake pedal to seat brake shoes.
- (10) Fill brake fluid reservoir.
- (11) Verify firm pedal before moving vehicle.

DISC BRAKE SHOES

REMOVAL

- (1) Clean master cylinder reservoir and filler caps.
- (2) Remove reservoir filler cap and drain approximately 1/4 of fluid from reservoir. Use clean suction gun or similar device to drain fluid.
- (3) Raise and support vehicle.
- (4) Remove front wheel and tire assemblies.
- (5) Bottom caliper pistons in bores with large C-clamp. Position clamp frame on rear of caliper and clamp screw on outboard brake shoe.
- (6) With a screw driver pry up on the caliper spring and pull the spring out of the caliper holes.
- (7) Remove caliper slide pins.
- (8) Remove caliper and brake shoes (Fig. 23).

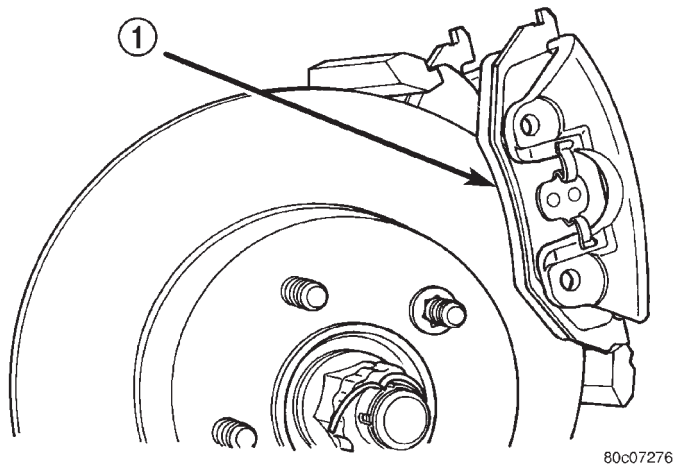
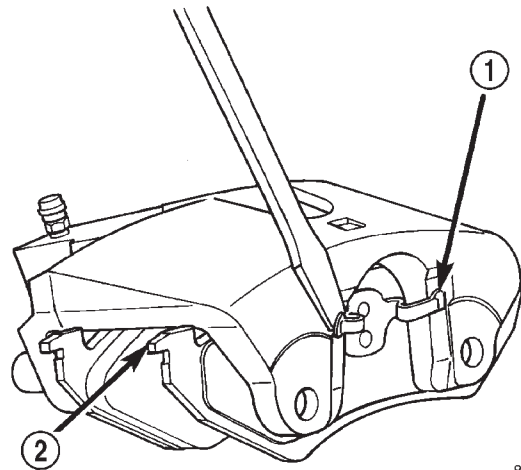

Fig. 23 Removing Caliper Assembly

1 - CALIPER AND BRAKE SHOES

- (9) Remove outboard brake shoe (Fig. 24). Pry one end of shoe retainer spring away from caliper. Then tilt shoe upward and rotate it out of caliper.
- (10) Remove inboard shoe by tilting shoe outward until retainer spring is clear of caliper piston (Fig. 25).



80c07277

Fig. 24 Outboard Brake Shoe

1 - SHOE SPRING
2 - OUTBOARD SHOE

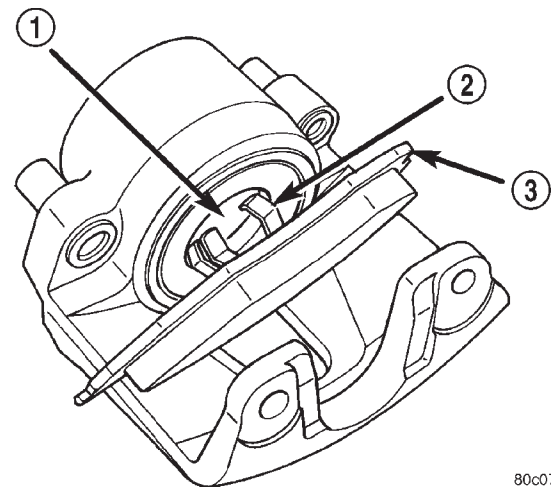

80c07278

Fig. 25 Inboard Brake Shoe

1 - CALIPER PISTON
2 - RETAINER SPRING
3 - INBOARD SHOE

(11) Support caliper with wire from suspension component. Do not allow brake hose to support caliper weight.

INSTALLATION

- (1) Clean slide surfaces of adapter ledges with a wire brush. Then lubricate surfaces with a thin coat of high temperature grease.
- (2) Install new slide pin bushings if necessary.
- (3) Install inboard shoe. Be sure retainer spring is firmly seated in caliper piston.
- (4) Insert outboard brake shoe in caliper (Fig. 26).
- (5) Insure the outboard shoe retainer spring are seated in the caliper (Fig. 27).

REMOVAL AND INSTALLATION (Continued)

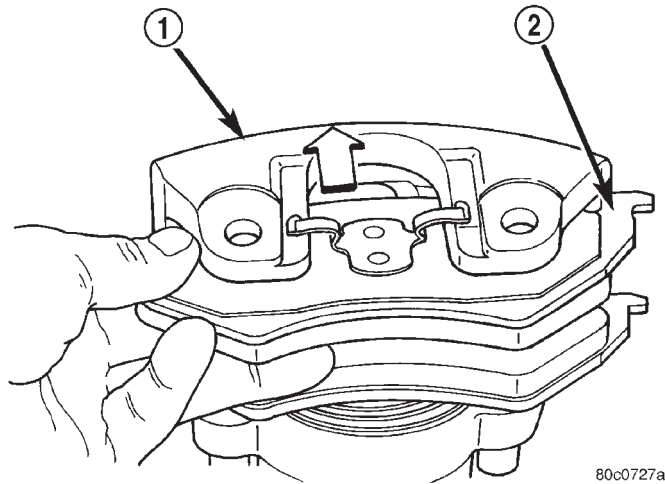

80c0727a

Fig. 26 Installing Outboard Shoe

- 1 - CALIPER
- 2 - OUTBOARD SHOE

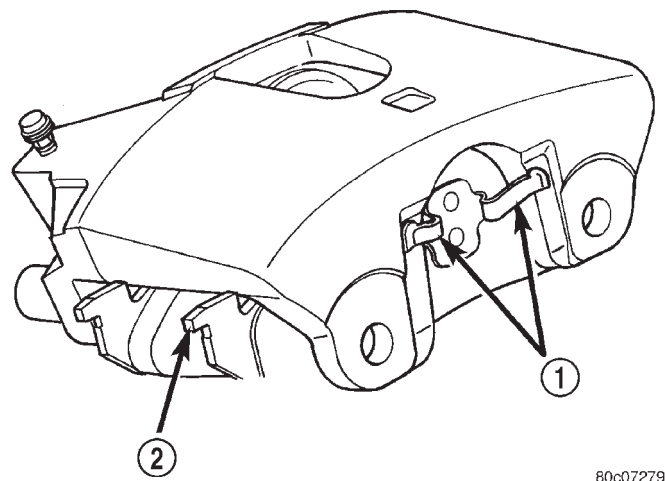

80c07279

Fig. 27 Outboard Shoe Retainer Spring

- 1 - SEAT RETAINER SPRING ENDS IN CALIPER
- 2 - OUTBOARD SHOE

(6) Install caliper and brake shoes over rotor and into adapter.

(7) Install and tighten caliper slide pins to 30 N·m (22 ft. lbs.). **Start the slide pins by hand before tightening. Do not cross thread the pins.**

(8) Install caliper spring into one caliper hole and under the adapter. Pull down on the opposite end of the spring (Fig. 28) and hold the end under the adapter. With a screwdriver pry up on the spring (Fig. 29) to seat the spring into the other caliper hole.

NOTE: Verify the spring is seated properly into the caliper holes.

(9) Install wheel and tire assembly.

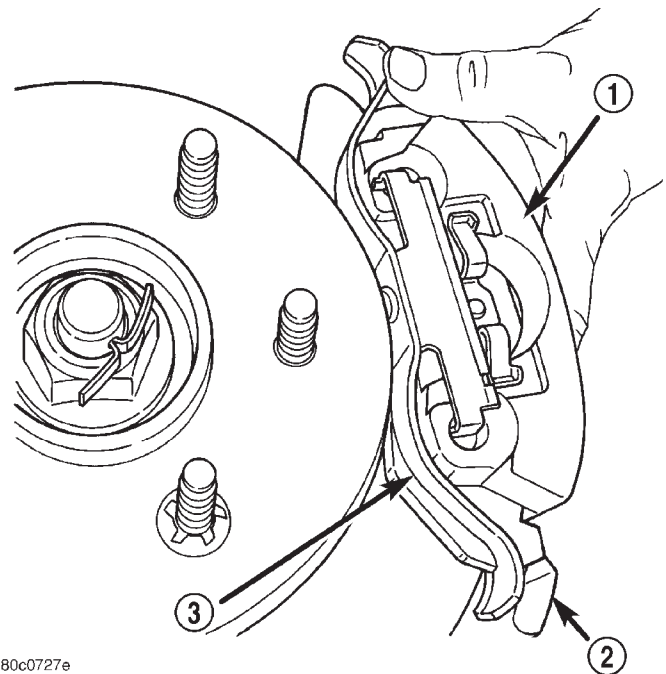

80c0727e

Fig. 28 Caliper Spring

- 1 - CALIPER
- 2 - ADAPTER
- 3 - CALIPER SPRING

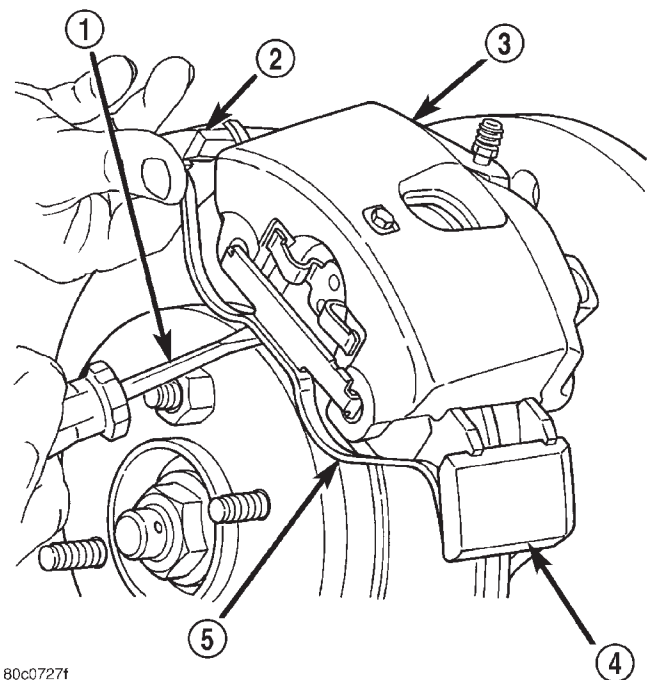

80c0727f

Fig. 29 Seat Caliper Spring

- 1 - SCREWDRIVER
- 2 - ADAPTER
- 3 - CALIPER
- 4 - ADAPTER
- 5 - CALIPER SPRING

REMOVAL AND INSTALLATION (Continued)

- (10) Remove support and lower vehicle.
- (11) Pump brake pedal to seat brake shoes.
- (12) Fill brake fluid reservoir.
- (13) Verify a firm brake pedal before moving vehicle.

DISC BRAKE ROTOR

REMOVAL

- (1) Raise and support vehicle.
- (2) Remove wheel and tire assembly.
- (3) Remove brake caliper.
- (4) Remove retainers on wheel studs and remove rotor.

INSTALLATION

- (1) Install rotor hub and install retainers.
- (2) Install brake caliper.
- (3) Install wheel and tire assembly.
- (4) Remove support and lower vehicle.
- (5) Depress brake pedal several time to seat brake shoes.

REAR BRAKE SHOES

REMOVAL

- (1) Raise and support vehicle.
- (2) Remove wheel and tire assembly.
- (3) Remove clip nuts securing brake drum to wheel studs.
- (4) Remove drum. If drum is difficult to remove, remove rear plug from access hole in support plate. Back-off self adjusting by inserting a thin screwdriver into access hole and push lever away from adjuster screw star wheel. Then insert an adjuster tool into brake adjusting hole rotate adjuster star wheel to retract brake shoes.
- (5) Vacuum brake components to remove brake lining dust.
- (6) Remove shoe return springs with brake spring plier tool (Fig. 30).
- (7) Remove adjuster cable. Slide cable eye off anchor pin. Then unhook and remove cable from adjuster lever.
- (8) Remove cable guide from secondary shoe and anchor plate from anchor pin.
- (9) Remove adjuster lever. Disengage lever from spring by sliding lever forward to clear pivot and work lever out from under spring.
- (10) Remove adjuster lever spring from pivot.
- (11) Disengage and remove shoe spring from brake shoes.
- (12) Disengage and remove adjuster screw assembly from brake shoes.
- (13) Remove brake shoe retainers, springs (Fig. 31).

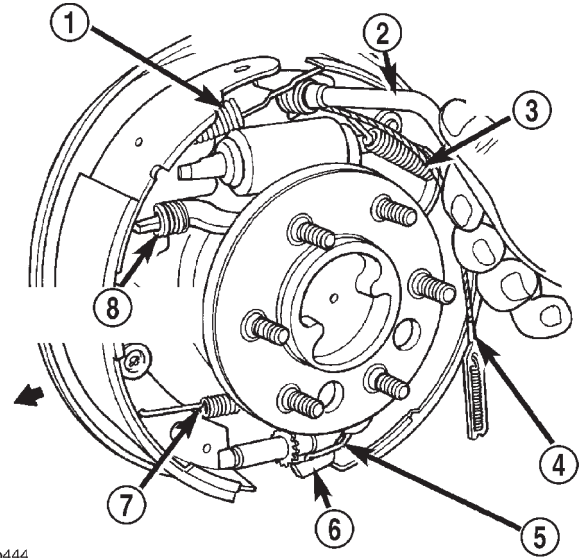

80b1b444

Fig. 30 Shoe Return Springs

- 1 - SHOE RETURN SPRING
- 2 - SPECIAL TOOL (REMOVING AND INSTALLING)
- 3 - SHOE RETURN SPRING
- 4 - ADJUSTER CABLE
- 5 - LEVER SPRING
- 6 - ADJUSTER LEVER
- 7 - SHOE TO SHOE SPRING
- 8 - ANTI-RATTLE SPRING

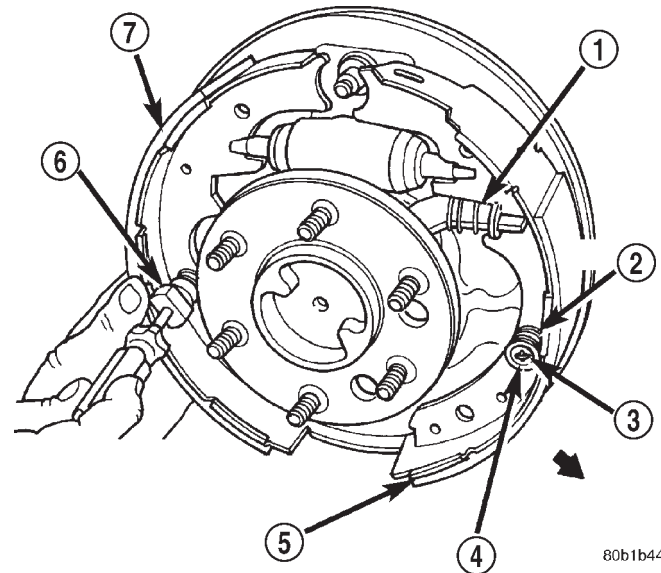

80b1b445

Fig. 31 Shoe Retainers, Springs and Pins

- 1 - STRUT AND SPRING
- 2 - SPRING
- 3 - PIN
- 4 - RETAINER
- 5 - PRIMARY SHOE AND LINING
- 6 - TOOL C-4070
- 7 - SECONDARY SHOE AND LINING

REMOVAL AND INSTALLATION (Continued)

(14) Remove secondary brake shoe from support plate.

(15) Remove strut and spring (Fig. 31).

(16) Remove parking brake lever retaining clip from the secondary shoe and remove the lever.

(17) Remove primary shoe from support plate.

(18) Disengage parking brake lever from parking brake cable.

INSTALLATION

(1) Clean and inspect individual brake components, refer to Cleaning and Inspection Section.

(2) Lubricate anchor pin and brake shoe contact pads on support plate with high temperature grease or Lubriplate (Fig. 32).

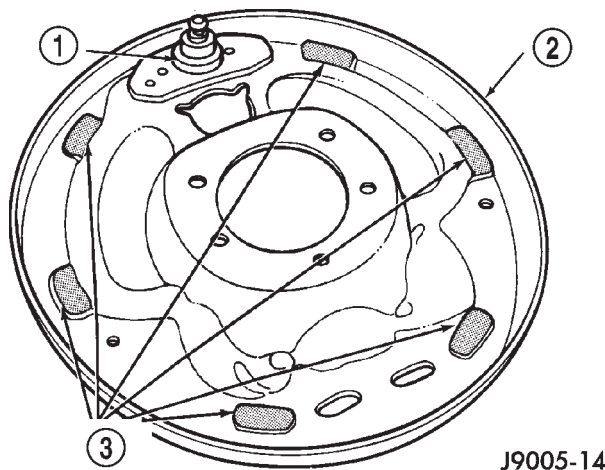

J9005-14

Fig. 32 Shoe Contact Surfaces

- 1 - ANCHOR PIN
- 2 - SUPPORT PLATE
- 3 - SHOE CONTACT SURFACES

(3) Lubricate adjuster screw socket, nut, button and screw thread surfaces with grease or Lubriplate.

(4) Install the parking brake cable to the parking brake lever.

(5) Install parking brake lever to the secondary shoe and install retaining clip.

(6) Install primary shoe on support plate. Secure shoe with new spring retainers and pin.

(7) Install spring on parking brake strut and engage strut in primary.

(8) Install secondary shoe on support plate (Fig. 33). Insert strut in shoe and guide shoe onto anchor pin. Temporarily secure shoe with retaining pin.

(9) Install anchor plate and adjuster cable eyelet on support plate anchor pin.

(10) Install cable guide in secondary shoe and position cable in guide.

(11) Assemble adjuster screw (Fig. 34). Then install and adjuster screw between the brake shoes.

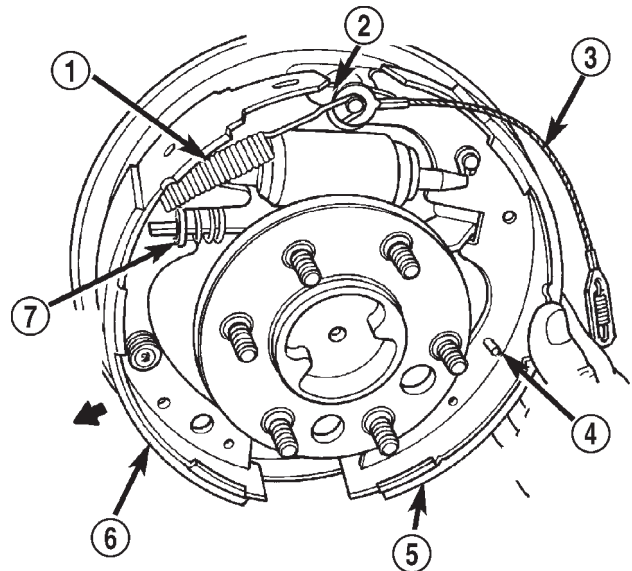

80b1b446

Fig. 33 Brake Shoe Installation

- 1 - SHOE RETURN SPRING
- 2 - ANCHOR PLATE
- 3 - ADJUSTER CABLE
- 4 - SHOE RETAINING PIN
- 5 - SECONDARY SHOE AND LINING
- 6 - PRIMARY SHOE AND LINING
- 7 - STRUT AND SPRING

CAUTION: Be sure the adjuster screws are installed on the correct brake unit. The adjuster screws are marked L (left) and R (right) for identification.

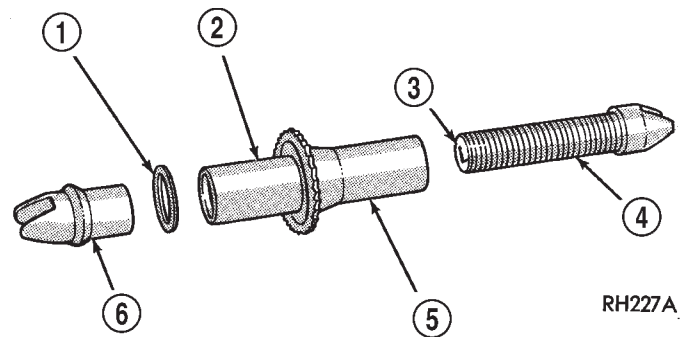

RH227A

Fig. 34 Adjuster Screw

- 1 - WASHER
- 2 - SOCKET
- 3 - STAMPED LETTER
L-LEFT BRAKE
R-RIGHT BRAKE
- 4 - SCREW THREADS
- 5 - NUT
- 6 - BUTTON

(12) Install adjuster lever and spring and connect adjuster cable to lever.

(13) Install secondary shoe retainers and spring.

REMOVAL AND INSTALLATION (Continued)

- (14) Install shoe spring. Connect spring to secondary shoe first. Then to primary shoe.
- (15) Verify adjuster operation. Pull adjuster cable upward, cable should lift lever and rotate star wheel. Be sure adjuster lever properly engages star wheel teeth.
- (16) Adjust brake shoes to drum with brake gauge.
- (17) Install wheel and tire assembly.

WHEEL CYLINDER

REMOVAL

- (1) Remove wheel and tire assembly.
- (2) Remove brake drum.
- (3) Disconnect wheel cylinder brake line.
- (4) Remove brake shoe return springs and move shoes out of engagement with cylinder push rods.
- (5) Remove cylinder attaching bolts and remove cylinder from support plate.

INSTALLATION

- (1) Apply bead of silicone sealer around cylinder mounting surface of support plate.
- (2) Install cylinder mounting bolts and tighten to 20 N·m (15 ft. lbs.).
- (3) Connect brake line to cylinder.
- (4) Install brake shoe return spring.
- (5) Install brake drum.
- (6) Install wheel and tire assembly.
- (7) Bleed base brake system.

BRAKE SUPPORT PLATE

REMOVAL

- (1) Remove wheel and tire assembly and brake drum.
- (2) Remove brake shoe assembly.
- (3) Remove parking brake cable from parking brake lever.
- (4) Compress parking brake cable retainer tabs. Then push retainer and cable through and out of support plate.
- (5) Disconnect brake line at wheel cylinder.
- (6) Remove wheel cylinder from support plate.
- (7) Remove axle shaft, refer to Group 3 for procedures.
- (8) Remove bolts attaching support plate to axle and remove support plate.

INSTALLATION

- (1) Apply bead of silicone sealer around axle mounting surface of support plate.
- (2) Install support plate on axle flange. Tighten attaching bolts to 115 N·m (85 ft. lbs.).
- (3) Apply bead of silicone sealer around wheel cylinder mounting surface and install wheel cylinder.
- (4) Install brake line in wheel cylinder.

- (5) Install parking brake cable in support plate.
- (6) Install axle shaft, refer to Group 3 for procedure.
- (7) Connect parking brake cable to lever on secondary shoe and install brake shoes on support plate.
- (8) Adjust brake shoes to drum with brake gauge.
- (9) Install brake drum and wheel and tire assembly.
- (10) Bleed brake system.

FRONT PARK BRAKE CABLE

REMOVAL

- (1) Raise and support the vehicle.
- (2) Loosen the cable adjuster nut (Fig. 35).
- (3) Pull cable through the body mount.
- (4) Remove support and lower vehicle.
- (5) Remove left kick panel.
- (6) Fold left front edge of floor covering rearward and remove cable grommet from floor pan.
- (7) Engage parking brake pedal and remove cable from park brake pedal assembly.
- (8) Pull the cable through the floor pan.
- (9) Remove cable from vehicle.

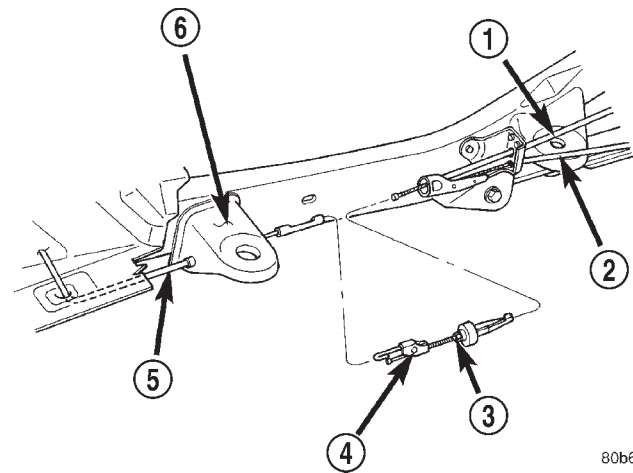

80b6b284

Fig. 35 Cable Tensioner

- 1 - RIGHT REAR CABLE
- 2 - LEFT REAR CABLE
- 3 - ADJUSTMENT NUT
- 4 - TENSIONER
- 5 - FRONT CABLE
- 6 - BODY MOUNT

INSTALLATION

- (1) Insert front cable through floor pan and install grommet.
- (2) Insert cable retainer into hole at bottom of pedal assembly bracket and connect cable end.
- (3) Install kick panel.
- (4) Raise and support vehicle.
- (5) Insert the cable through the body mount.

REMOVAL AND INSTALLATION (Continued)

- (6) Connect the cable to the tensioner.
- (7) Perform parking brake adjustment procedure.
- (8) Remove support and lower vehicle.

REAR PARK BRAKE CABLES

REMOVAL

- (1) Raise and support the vehicle.
- (2) Remove the rear wheel and tire assemblies.
- (3) Loosen tensioner adjuster nut.
- (4) Remove the right cable from the tensioner and pull the cable housing through the left cable connector (Fig. 36).

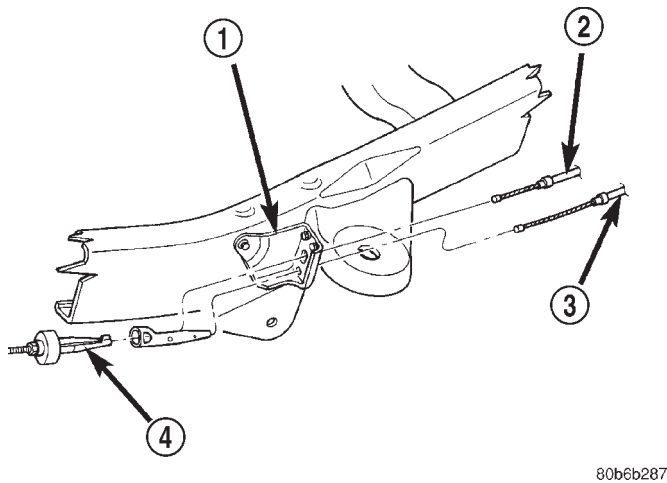
**Fig. 36 Cable Connectors**

- 1 - CABLE BRACKET
- 2 - RIGHT CABLE
- 3 - LEFT CABLE
- 4 - TENSIONER CONNECTOR

- (5) Remove the left cable connector.
- (6) Pull both cables through the cable bracket.
- (7) Remove the right cable mounting retainers from the stabilizer bar retainers (Fig. 37) and remove the cable from the differential housing (Fig. 38).
- (8) Remove the brake drums.
- (9) Disconnect each cable from park brake lever.
- (10) Compress tabs on each cable housing retainer at the brake support plate.
- (11) Remove the cables from the brake support plates.

INSTALLATION

- (1) Push each cable housing through the brake support plate hole until cable housing retainer tabs lock into place.

NOTE: Pull on the cable housing to ensure it is lock into place.

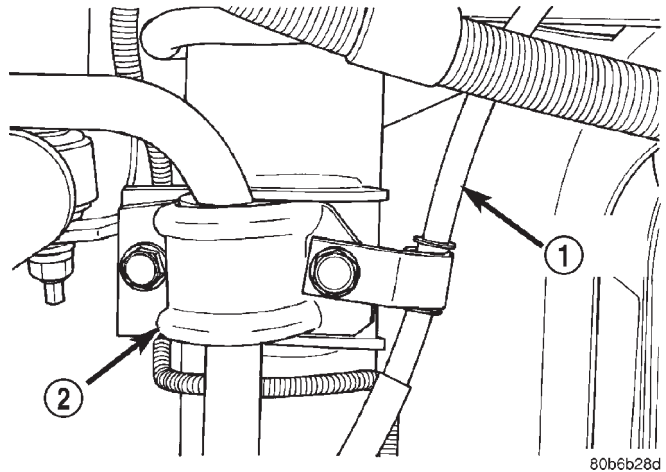
**Fig. 37 Stabilizer Bar Retainer**

- 1 - RIGHT CABLE
- 2 - STABILIZER BAR RETAINER

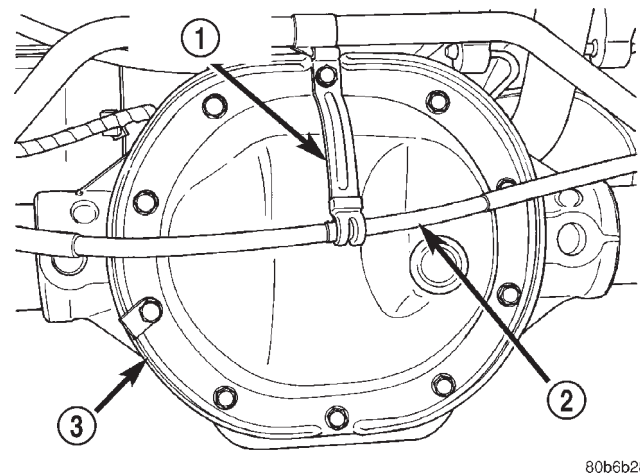
**Fig. 38 Cable Retainers**

- 1 - CABLE RETAINER
- 2 - RIGHT CABLE
- 3 - DIFFERENTIAL HOUSING

- (2) Pull back on the end of the cable. Then push the cable in to engage the cable in the park brake lever.

NOTE: Pull on the cable end to ensure it is attached it the park brake lever.

- (3) Install the brake drums.
- (4) Install right cable mounting retainers.
- (5) Push the cables housing through the cable bracket
- (6) Install the left cable onto the cable connector.
- (7) Push the right cable housing through the left cable connector and connect the cable to the tensioner.
- (8) Install the wheel and tire assemblies.

REMOVAL AND INSTALLATION (Continued)

- (9) Perform park brake adjustment procedure.
- (10) Remove support and lower the vehicle.

PARK BRAKE PEDAL ASSEMBLY

Removal

- (1) Remove left side kick panel.
- (2) Remove brake release rod from pedal assembly (Fig. 39).
- (3) Disconnect brake warning lamp switch.
- (4) Remove front parking brake cable.
- (5) Remove mounting nuts and mounting bolt.
- (6) Slide assembly rearward off the mounting studs (Fig. 39).

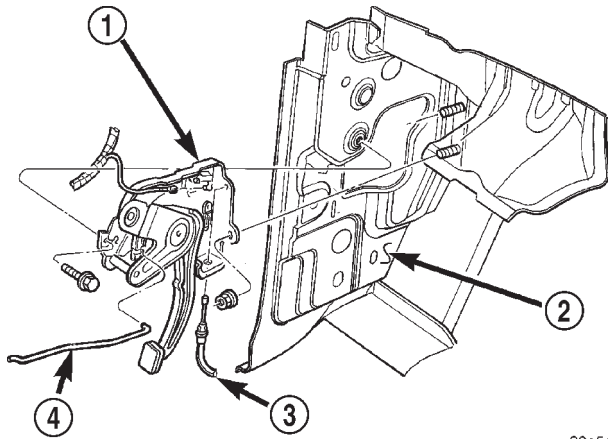

80a5cef3

Fig. 39 Parking Brake Pedal Assembly

- 1 - PARKING BRAKE ASSEMBLY
- 2 - LEFT COWL PANEL
- 3 - FRONT CABLE
- 4 - RELEASE ROD

Installation

- (1) Install assembly on the mounting studs.
- (2) Install mounting bolt and nuts.
- (3) Install front parking brake cable.
- (4) Connect brake warning lamp switch.
- (5) Install brake release rod to pedal assembly.
- (6) Install left side kick panel.

DISASSEMBLY AND ASSEMBLY

MASTER CYLINDER RESERVOIR

REMOVAL

- (1) Remove reservoir cap and empty fluid into drain container.
- (2) Clamp cylinder body in vise with brass protective jaws.

- (3) Remove pins that retain reservoir to master cylinder. Use hammer and pin punch to remove pins (Fig. 40).

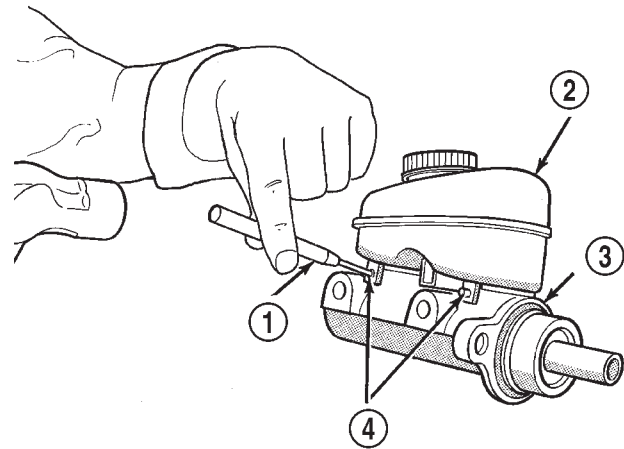

J9505-77

Fig. 40 Reservoir Retaining Pins

- 1 - PIN PUNCH
- 2 - RESERVOIR
- 3 - BODY
- 4 - ROLL PINS

- (4) Loosen reservoir from grommets with pry tool (Fig. 41).

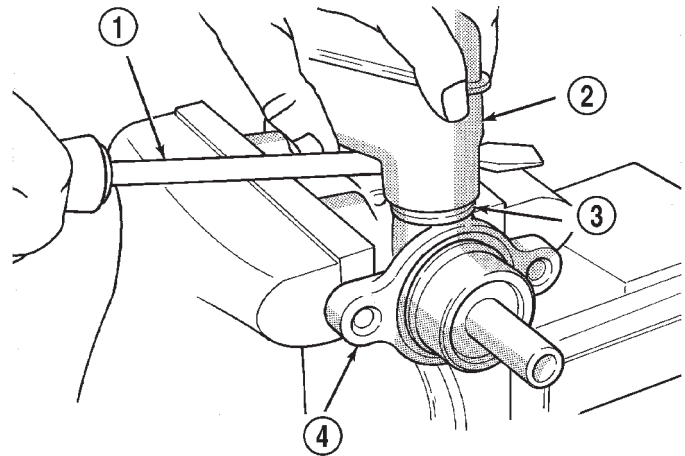

J9505-47

Fig. 41 Loosening Reservoir

- 1 - PRY TOOL
- 2 - RESERVOIR
- 3 - GROMMET
- 4 - MASTER CYLINDER BODY

- (5) Remove reservoir by rocking it to one side and pulling free of grommets (Fig. 42).

- (6) Remove old grommets from cylinder body (Fig. 43).

DISASSEMBLY AND ASSEMBLY (Continued)

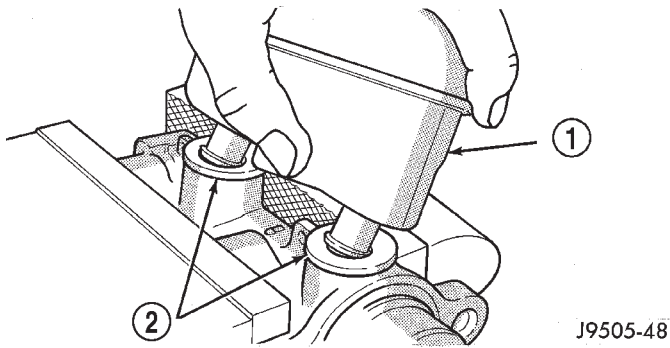
**Fig. 42 Reservoir Removal**

- 1 - RESERVOIR
2 - GROMMETS

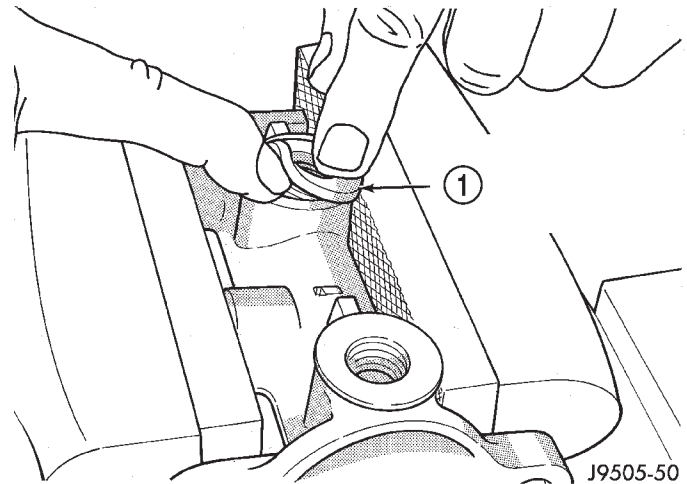
**Fig. 44 Grommet Installation**

- 1 - WORK NEW GROMMETS INTO PLACE USING FINGER PRESSURE ONLY

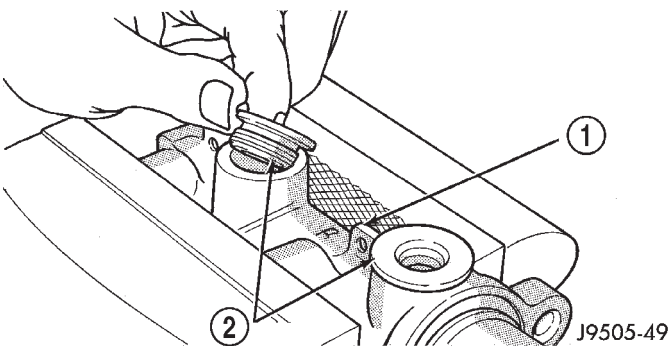
**Fig. 43 Grommet Removal**

- 1 - MASTER CYLINDER BODY
2 - GROMMETS

INSTALLATION

CAUTION: Do not use any type of tool to install the grommets. Tools may cut, or tear the grommets creating a leak problem after installation. Install the grommets using finger pressure only.

(1) Lubricate new grommets with clean brake fluid and install new grommets in cylinder body (Fig. 44). Use finger pressure to install and seat grommets.

(2) Start reservoir in grommets. Then rock reservoir back and forth while pressing downward to seat it in grommets.

(3) Install pins that retain reservoir to cylinder body.

(4) Fill and bleed master cylinder on bench before installation in vehicle.

DISC BRAKE CALIPER

DISASSEMBLY

(1) Drain old brake fluid out of caliper into drain pan.

(2) Remove piston dust boot (Fig. 45). Use screwdriver to push boot out of groove.

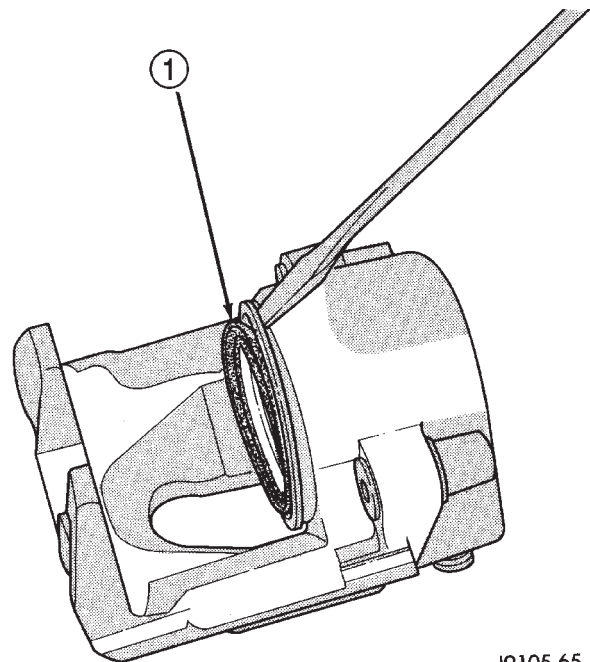
**Fig. 45 Piston Dust Boot**

- 1 - PISTON BOOT DUST

(3) Pad outboard shoe side of caliper interior with a minimum 1 inch thickness of shop towels (Fig. 46). Towels will prevent piston damage when piston comes out of the caliper bore.

(4) Remove caliper piston with short bursts of compressed air. Apply air pressure through fluid inlet port of caliper (Fig. 46).

DISASSEMBLY AND ASSEMBLY (Continued)

CAUTION: Do not blow the piston out of the bore with sustained air pressure. This could result in a cracked piston. Use only enough air pressure to ease the piston out.

WARNING: NEVER ATTEMPT TO CATCH THE PISTON AS IT LEAVES THE BORE. THIS MAY RESULT IN PERSONAL INJURY.

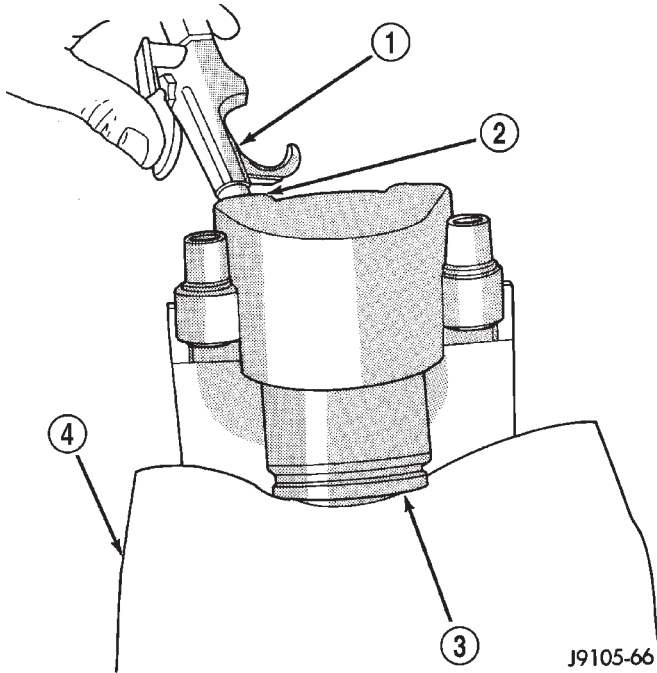

Fig. 46 Caliper Piston

- 1 - AIR GUN NOZZLE
- 2 - FLUID INLET PORT
- 3 - CALIPER PISTON
- 4 - PADDING MATERIAL (TO PROTECT PISTON)

(5) Remove caliper piston seal with wood pencil or plastic tool (Fig. 47). Do not use metal tools as they will scratch piston bore.

(6) Remove caliper slide pin bushings and boots.

(7) Remove caliper bleed screw and cap.

ASSEMBLY

(1) Lubricate slide pin boots and bushings with GE, or Dow silicone grease. Then install the boots and bushings in caliper.

(2) Coat caliper piston bore, piston and new piston seal with clean brake fluid.

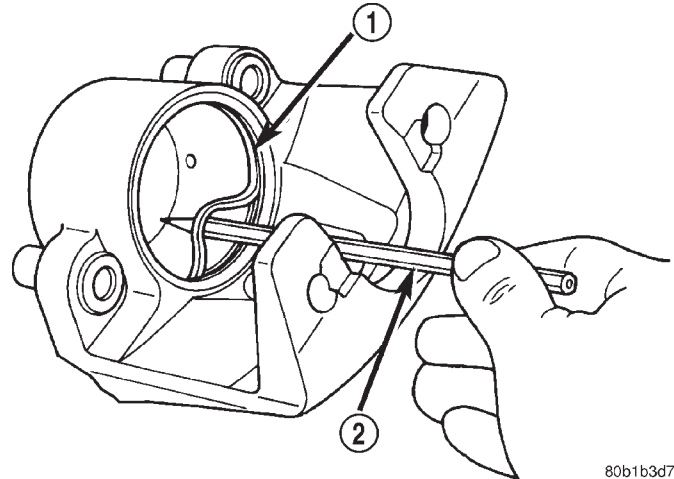

Fig. 47 Caliper Piston Seal

- 1 - PISTON SEAL
- 2 - WOOD PENCIL

(3) Install new piston seal in caliper bore. Press seal into groove with finger (Fig. 48). Lubricate seal and caliper bore with additional, fresh brake fluid after seal installation.

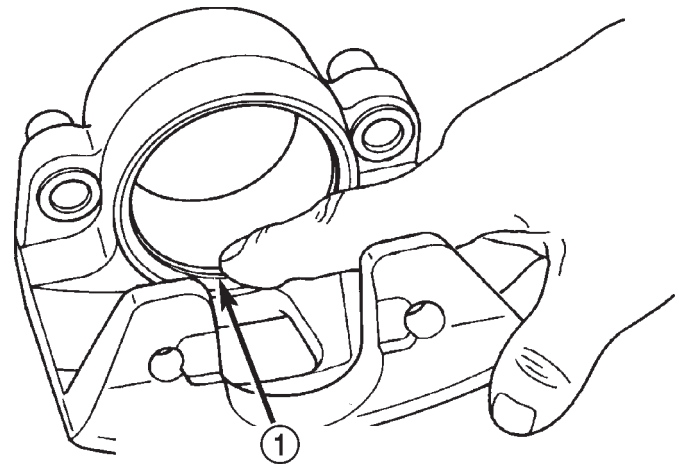

Fig. 48 Caliper Piston Seal

- 1 - CALIPER PISTON SEAL
(PRESS SEAL INTO PLACE WITH FINGER)

(4) Apply light coat of GE 661, Dow 111 or similar silicone grease to edge and groove of piston and dust seal. Grease acts as corrosion protection for these areas.

DISASSEMBLY AND ASSEMBLY (Continued)

(5) Slide new seal boot over piston until boot lip seats in piston groove (Fig. 49).

(6) Push retainer part of boot forward until folds in boot snap into place (Fig. 50).

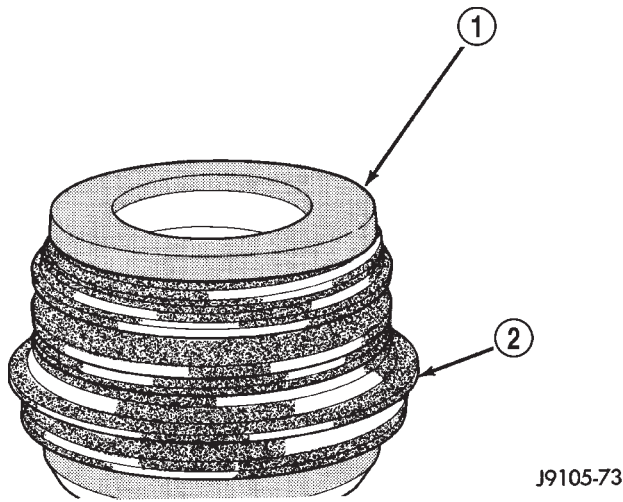

Fig. 49 Sliding Boot Onto Piston

- 1 - CALIPER PISTON
- 2 - SLIDE DUST BOOT DOWNWARD OVER PISTON

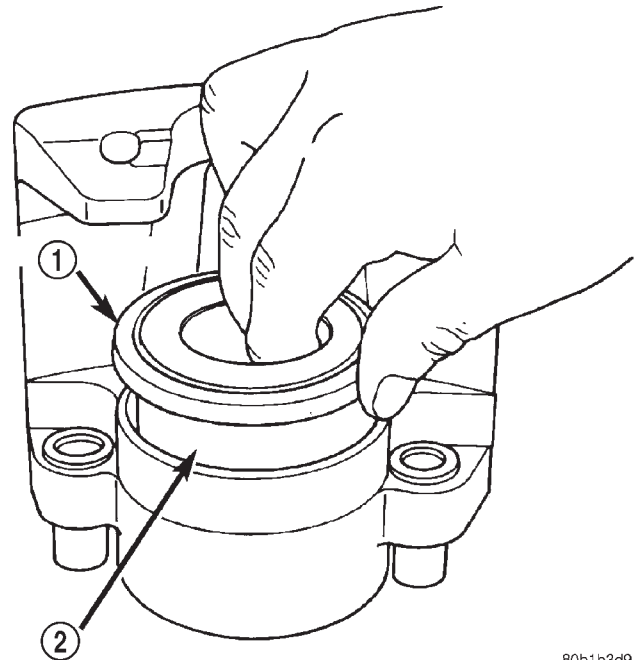

Fig. 51 Installing Caliper Piston And Boot

- 1 - DUST BOOT
- 2 - CALIPER PISTON

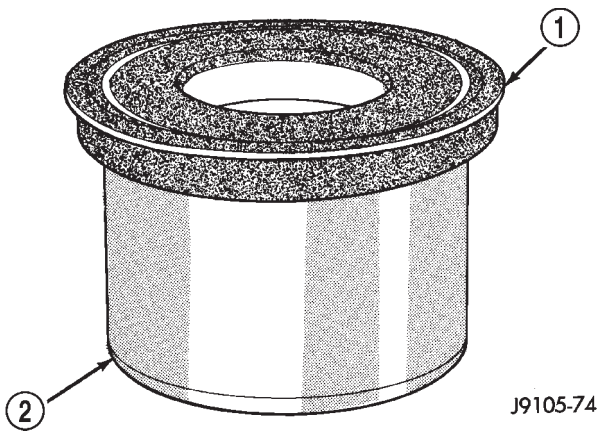

Fig. 50 Snapping Boot Folds Into Place

- 1 - FOLD DUST BOOT UPWARD UNTIL IT "SNAPS" INTO PLACE
- 2 - CALIPER PISTON

(7) Start caliper piston in bore with a twisting motion. When piston is started in seal, push piston only **part way** into bore (Fig. 51). Maintain uniform pressure on piston to avoid cocking it in bore.

(8) Press caliper piston to bottom of bore.
 (9) Seat piston dust boot with Installer 8248 and Handle C-4171 (Fig. 52).

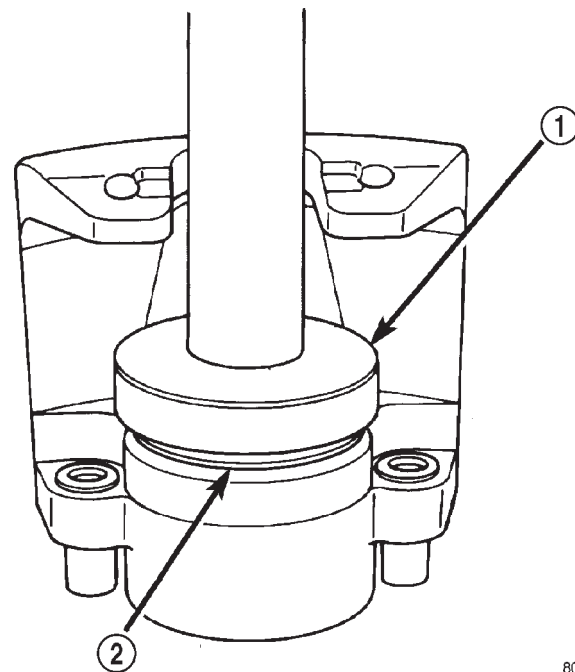

Fig. 52 Seating Piston Dust Boot

- 1 - SEAL INSTALLER
- 2 - DUST BOOT

DISASSEMBLY AND ASSEMBLY (Continued)

(10) Install caliper bleed screw and bleed screw cap if removed (Fig. 53).

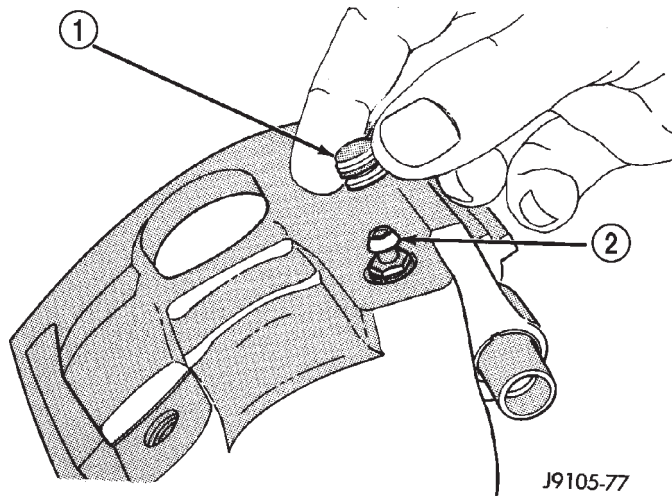

Fig. 53 Installing Caliper Bleed Screw And Cap

- 1 - BLEED SCREW CAP
- 2 - BLEED SCREW

WHEEL CYLINDER

DISASSEMBLY

- (1) Remove push rods and boots (Fig. 54).
- (2) Press pistons, cups and spring and expander out of cylinder bore.
- (3) Remove bleed screw.

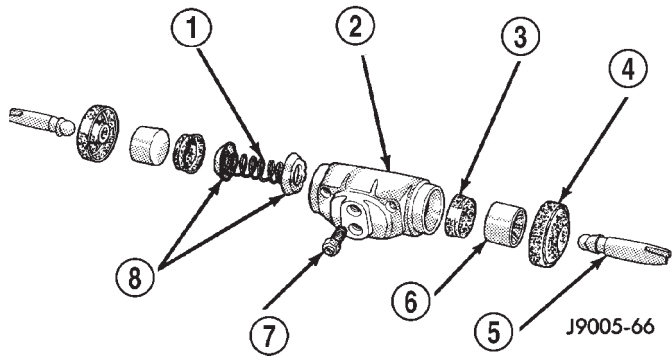

Fig. 54 Wheel Cylinder Components—Typical

- 1 - SPRING
- 2 - CYLINDER
- 3 - PISTON CUP
- 4 - BOOT
- 5 - PUSH ROD
- 6 - PISTON
- 7 - BLEED SCREW
- 8 - CUP EXPANDERS

ASSEMBLY

- (1) Lubricate wheel cylinder bore, pistons, piston cups and spring and expander with clean brake fluid.
- (2) Install first piston in cylinder bore. Then install first cup in bore and against piston. **Be sure lip of piston cup is facing inward (toward spring and expander) and flat side is against piston.**
- (3) Install spring and expander followed by remaining piston cup and piston.
- (4) Install boots on each end of cylinder and insert push rods in boots.
- (5) Install cylinder bleed screw.

CLEANING AND INSPECTION

REAR DRUM BRAKE

CLEANING

Clean the individual brake components, including the support plate and wheel cylinder exterior, with a water dampened cloth or with brake cleaner. Do not use any other cleaning agents. Remove light rust and scale from the brake shoe contact pads on the support plate with fine sandpaper.

INSPECTION

As a general rule, riveted brake shoes should be replaced when worn to within 0.78 mm (1/32 in.) of the rivet heads. Bonded lining should be replaced when worn to a thickness of 1.6 mm (1/16 in.).

Examine the lining contact pattern to determine if the shoes are bent or the drum is tapered. The lining should exhibit contact across its entire width. Shoes exhibiting contact only on one side should be replaced and the drum checked for runout or taper.

Inspect the adjuster screw assembly. Replace the assembly if the star wheel or threads are damaged, or the components are severely rusted or corroded.

Discard the brake springs and retainer components if worn, distorted or collapsed. Also replace the springs if a brake drag condition had occurred. Overheating will distort and weaken the springs.

Inspect the brake shoe contact pads on the support plate, replace the support plate if any of the pads are worn or rusted through. Also replace the plate if it is bent or distorted (Fig. 55).

CALIPER

CLEANING

Clean the caliper components with clean brake fluid or brake clean only. Wipe the caliper and piston dry with lint free towels or use low pressure compressed air.

CLEANING AND INSPECTION (Continued)

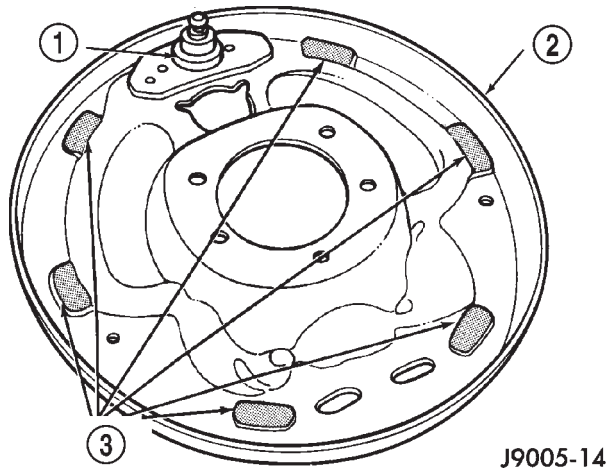

Fig. 55 Shoe Contact Surfaces

- 1 - ANCHOR PIN
- 2 - SUPPORT PLATE
- 3 - SHOE CONTACT SURFACES

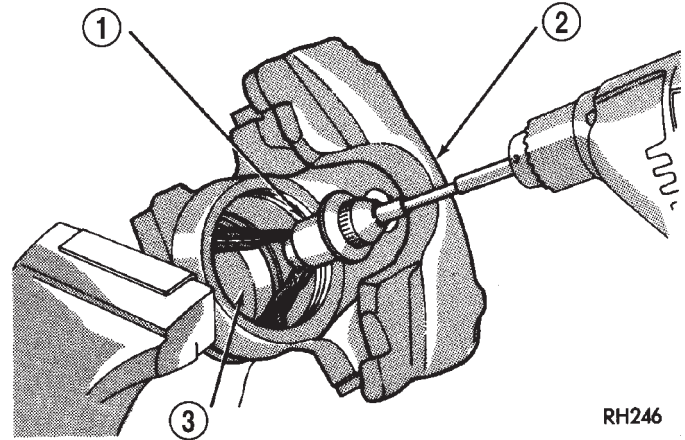

Fig. 56 Polishing Piston Bore

- 1 - SPECIAL HONE
- 2 - CALIPER
- 3 - PISTON BORE

RH246

CAUTION: Do not use gasoline, kerosene, paint thinner, or similar solvents. These products may leave a residue that could damage the piston and seal.

INSPECTION

The piston is made from a phenolic resin (plastic material) and should be smooth and clean.

The piston must be replaced if cracked or scored. Do not attempt to restore a scored piston surface by sanding or polishing.

CAUTION: If the caliper piston is replaced, install the same type of piston in the caliper. Never interchange phenolic resin and steel caliper pistons. The pistons, seals, seal grooves, caliper bore and piston tolerances are different.

The bore can be **lightly** polished with a brake hone to remove very minor surface imperfections (Fig. 56). The caliper should be replaced if the bore is severely corroded, rusted, scored, or if polishing would increase bore diameter more than 0.025 mm (0.001 inch).

WHEEL CYLINDER

CLEANING

Clean the cylinder and pistons with clean brake fluid or brake cleaner only. Do not use any other cleaning agents.

Dry the cylinder and pistons with compressed air. Do not use rags or shop towels to dry the cylinder components. Lint from cloth material will adhere to the cylinder bores and pistons.

INSPECTION

Inspect the cylinder bore. Light discoloration and dark stains in the bore are normal and will not impair cylinder operation.

The cylinder bore can be lightly polished but only with crocus cloth. Replace the cylinder if the bore is scored, pitted or heavily corroded. Honing the bore to restore the surface is not recommended.

Inspect the cylinder pistons. The piston surfaces should be smooth and free of scratches, scoring and corrosion. Replace the pistons if worn, scored, or corroded. Do attempt to restore the surface by sanding or polishing.

Discard the old piston cups and the spring and expander. These parts are not reusable. The original dust boots may be reused but only if they are in good condition.

ADJUSTMENTS

REAR DRUM BRAKE

The rear drum brakes are equipped with a self-adjusting mechanism. Under normal circumstances, the only time adjustment is required is when the shoes are replaced, removed for access to other parts, or when one or both drums are replaced.

Adjustment can be made with a standard brake gauge or with adjusting tool. Adjustment is performed with the complete brake assembly installed on the backing plate.

ADJUSTMENT WITH BRAKE GAUGE

- (1) Be sure parking brakes are fully released.
- (2) Raise rear of vehicle and remove wheels and brake drums.

ADJUSTMENTS (Continued)

(3) Verify that left and right automatic adjuster levers and cables are properly connected.

(4) Insert brake gauge in drum. Expand gauge until gauge inner legs contact drum braking surface. Then lock gauge in position (Fig. 57).

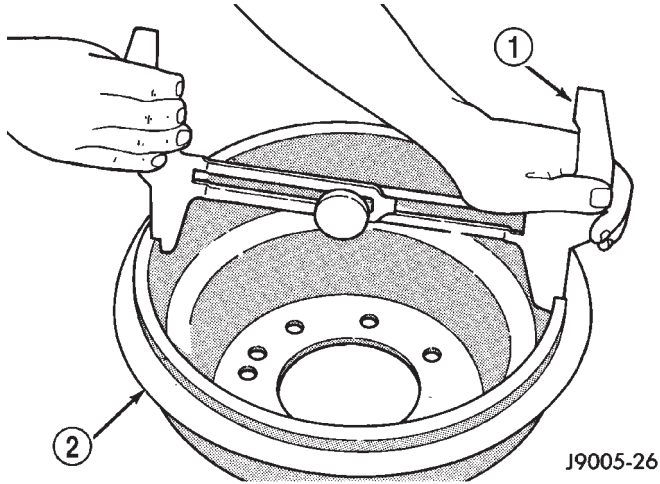

Fig. 57 Adjusting Gauge On Drum

- 1 - BRAKE GAUGE
- 2 - BRAKE DRUM

(5) Reverse gauge and install it on brake shoes. Position gauge legs at shoe centers as shown (Fig. 58). If gauge does not fit (too loose/too tight), adjust shoes.

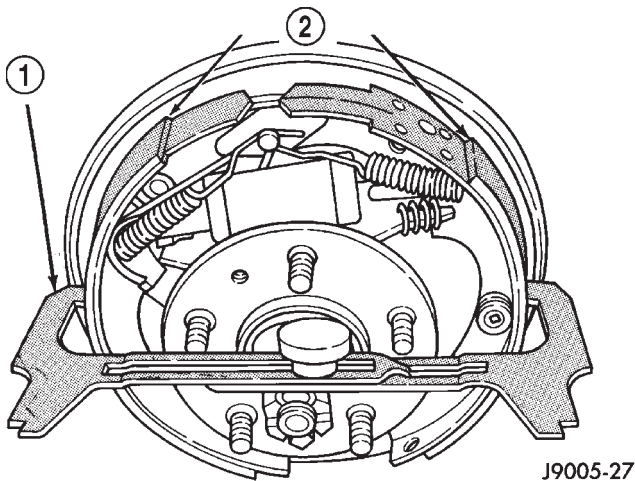

Fig. 58 Adjusting Gauge On Brake Shoes

- 1 - BRAKE GAUGE
- 2 - BRAKE SHOES

(6) Pull shoe adjuster lever away from adjuster screw star wheel.

(7) Turn adjuster screw star wheel (by hand) to expand or retract brake shoes. Continue adjustment until gauge outside legs are light drag-fit on shoes.

(8) Install brake drums and wheels and lower vehicle.

(9) Drive vehicle and make one forward stop followed by one reverse stop. Repeat procedure 8-10 times to operate automatic adjusters and equalize adjustment.

NOTE: Bring vehicle to complete standstill at each stop. Incomplete, rolling stops will not activate automatic adjusters.

ADJUSTMENT WITH ADJUSTING TOOL

(1) Be sure parking brake lever is fully released.
 (2) Raise vehicle so rear wheels can be rotated freely.

(3) Remove plug from each access hole in brake support plates.

(4) Loosen parking brake cable adjustment nut until there is slack in front cable.

(5) Insert adjusting tool through support plate access hole and engage tool in teeth of adjusting screw star wheel (Fig. 59).

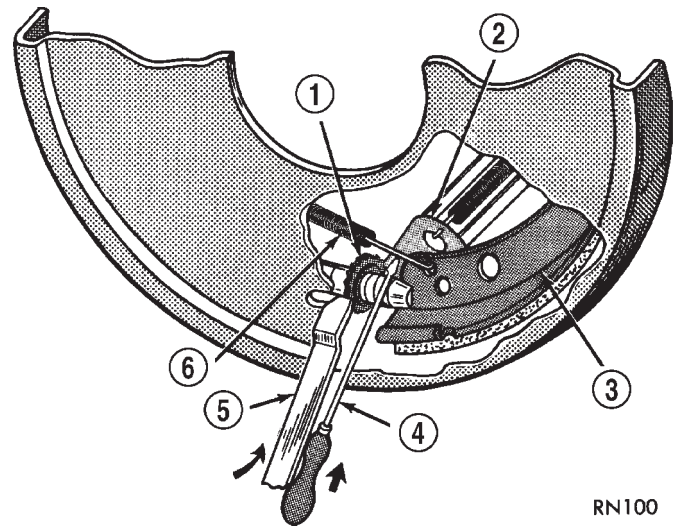

Fig. 59 Brake Adjustment

- 1 - STAR WHEEL
- 2 - LEVER
- 3 - BRAKE SHOE WEB
- 4 - SCREWDRIVER
- 5 - ADJUSTING TOOL
- 6 - ADJUSTER SPRING

(6) Rotate adjuster screw star wheel (move tool handle upward) until slight drag can be felt when wheel is rotated.

(7) Push and hold adjuster lever away from star wheel with thin screwdriver.

(8) Back off adjuster screw star wheel until brake drag is eliminated.

ADJUSTMENTS (Continued)

(9) Repeat adjustment at opposite wheel. Be sure adjustment is equal at both wheels.

(10) Install support plate access hole plugs.

(11) Adjust parking brake cable and lower vehicle.

(12) Drive vehicle and make one forward stop followed by one reverse stop. Repeat procedure 8-10 times to operate automatic adjusters and equalize adjustment.

NOTE: Bring vehicle to complete standstill at each stop. Incomplete, rolling stops will not activate automatic adjusters.

PARK BRAKE CABLE TENSIONER

NOTE: Tensioner adjustment is only necessary when the tensioner, or a cable has been replaced or disconnected for service. When adjustment is necessary, perform adjustment only as described in the following procedure. This is necessary to avoid faulty park brake operation.

(1) Raise vehicle.

(2) Back off cable tensioner adjusting nut create slack in cables.

(3) Remove rear wheel/tire assemblies. Then remove brake drums.

(4) Verify brakes are in good condition and operating properly.

(5) Verify park brake cables operate freely and are not binding, or seized.

(6) Check rear brake shoe adjustment with standard brake gauge.

(7) Install drums and verify that drums rotate freely without drag.

(8) Install wheel/tire assemblies.

(9) Lower vehicle enough for access to park brake foot pedal. Then fully apply park brakes.

NOTE: Leave park brakes applied until adjustment is complete.

(10) Raise vehicle again.

(11) Mark tensioner rod 6.35 mm (1/4 in.) from edge of tensioner if no mark is visible (Fig. 60).

NOTE: The rod is marked from the factory.

(12) Tighten adjusting nut on tensioner until the 1/4 inch mark is no longer visible.

CAUTION: Do not loosen, or tighten the tensioner adjusting nut for any reason after completing adjustment.

(13) Lower vehicle until rear wheels are 15-20 cm (6-8 in.) off shop floor.

(14) Release park brake foot pedal and verify that rear wheels rotate freely without drag. Then lower vehicle.

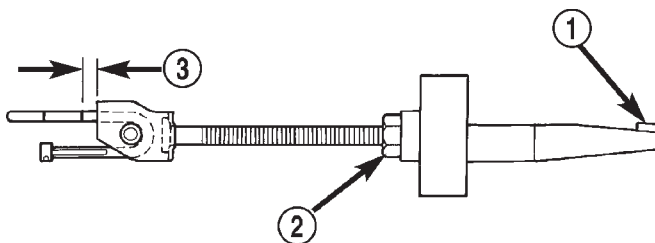

80b6b2a0

Fig. 60 Adjustment Mark On Cable Tensioner Rod

1 - CABLE CONNECTOR

2 - ADJUSTER NUT

3 - 6.35MM (1/4 IN.)

SPECIFICATIONS

BRAKE FLUID

The brake fluid used in this vehicle must conform to DOT 3 specifications and SAE J1703 standards. No other type of brake fluid is recommended or approved for usage in the vehicle brake system. Use only Mopar brake fluid or an equivalent from a tightly sealed container.

CAUTION: Never use reclaimed brake fluid or fluid from an container which has been left open. An open container of brake fluid will absorb moisture from the air and contaminate the fluid.

CAUTION: Never use any type of a petroleum-based fluid in the brake hydraulic system. Use of such type fluids will result in seal damage of the vehicle brake hydraulic system causing a failure of the vehicle brake system. Petroleum based fluids would be items such as engine oil, transmission fluid, power steering fluid, etc.

SPECIFICATIONS (Continued)

BASE BRAKES

Disc Brake Caliper

Type Sliding
 Bore 70 mm (2.75 in.)

Disc Brake Rotor

Type Ventilated
 Dimensions 287 x 24 mm (11.3 x 0.9 in.)
 Max. Runout 0.102 mm (0.004)
 Max. Thickness Variation 0.013 mm
 (0.0005 in.)
 Min. Rotor Thickness 22.6 mm (0.8898 in.)

Brake Drum

Dimensions 279 x 57 mm (11 x 2.25 in.)
 Max. Runout 0.20 mm (0.008 in.)
 Max. Diameter Variation... 0.076 mm (0.003 in.)

Brake Booster

Type Tandem Diaphragm

Master Cylinder

Bore 29 mm (1.125 in.)

TORQUE CHART

DESCRIPTION	TORQUE
Brake Booster	
Mounting Nuts	28 N·m (250 in. lbs.)
Master Cylinder	
Mounting Nuts	18 N·m (160 in. lbs.)
Caliper	
Mounting Pins	30 N·m (22 ft. lbs.)
Wheel Cylinder	
Bolts	20 N·m (15 ft. lbs.)
Combination Valve	
Bolt (RWAL)	20-27 N·m (15-20 ft. lbs.)
Bolt (ABS)	10-13 N·m (7-10 ft. lbs.)
Support Plate	
Mounting Bolts/Nuts	64 N·m (47 ft. lbs)
Brake Line Fittings	
Master Cylinder	19 N·m (170 in. lbs.)
Combination Valve	19 N·m (170 in. lbs.)
Wheel Cylinder	16 N·m (145 in. lbs.)
Brake Hose	
Front Fitting	16 N·m (145 in. lbs.)
Front Bolt	28 N·m (250 in. lbs.)
Rear Fitting	19 N·m (170 in. lbs.)

SPECIAL TOOLS

BASE BRAKES

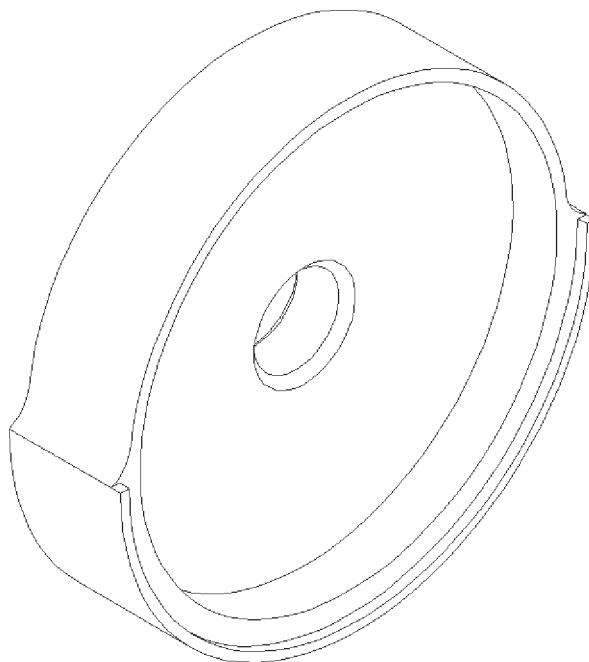

Install Dust Boot 8248

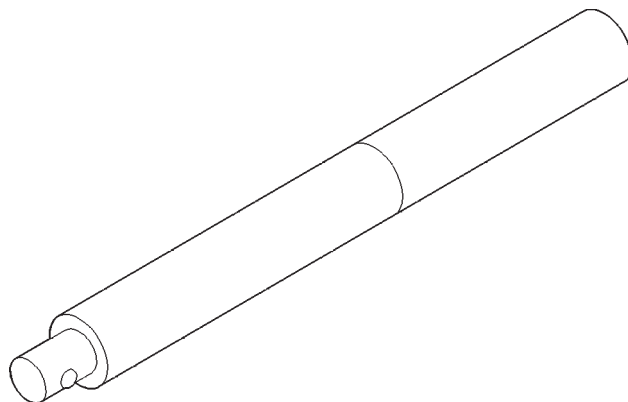

Universal Handle C-4171

REAR WHEEL ANTILOCK BRAKES

TABLE OF CONTENTS

	page		page
DESCRIPTION AND OPERATION		RWAL SERVICE PRECAUTIONS	36
REAR WHEEL ANTILOCK	32	SERVICE PROCEDURES	
RWAL COMPONENT LOCATION	33	REAR WHEEL ANTILOCK BRAKE BLEEDING . . .	37
CONTROLLER REAR WHEEL ANTILOCK BRAKES	33	REMOVAL AND INSTALLATION	
RWAL VALVE	34	CONTROLLER	37
REAR WHEEL SPEED SENSOR AND EXCITER RING	34	RWAL VALVE	38
BRAKE WARNING LAMPS	35	REAR WHEEL SPEED SENSOR	38
BRAKE LAMP SWITCH	36	EXCITER RING	39
DIAGNOSIS AND TESTING		SPECIFICATIONS	
REAR WHEEL ANTILOCK	36	TORQUE CHART	39

DESCRIPTION AND OPERATION

REAR WHEEL ANTILOCK

DESCRIPTION

Rear Wheel Antilock (RWAL) brake system is standard equipment. The RWAL brake system is designed to prevent rear wheel lock-up under heavy braking conditions on virtually all types of road surfaces. RWAL braking is desirable because a vehicle which is stopped without locking the wheels will retain directional stability. This allows the driver to retain greater control of the vehicle during braking.

The RWAL components include:

- RWAL Valve
- Controller Antilock brake (CAB)
- Rear Wheel Speed Sensor (WSS)

OPERATION

When the brakes are applied, hydraulic fluid is routed from the master cylinder's secondary circuit, through the combination valve, to the RWAL valve. From there hydraulic fluid is routed to the rear brake wheel cylinders. The Controller Antilock Brake monitors rear wheel speed through the rear wheel speed sensor. If a wheel is about to lock-up, the CAB signals the RWAL valve. The RWAL valve modulates the hydraulic brake pressure to the rear wheels to prevent wheel lock-up.

NORMAL BRAKING

During light brake application, rear wheel deceleration is not sufficient to activate the antilock system components. During a normal stop hydraulic brake fluid flows unrestricted to the rear wheel cylinders to stop the vehicle. The antilock solenoid valves are inactive. The isolation valve is open and the dump valve is closed allowing normal fluid flow to the rear wheel cylinders.

REAR WHEEL ANTILOCK BRAKING

If the CAB senses impending rear wheel lock-up, it will energize the isolation solenoid. This prevents a further increase of driver induced brake pressure to the rear wheels. If this initial action is not enough to prevent rear wheel lock-up, the CAB will momentarily energize a dump solenoid. This opens the dump valve to vent a small amount of isolated rear brake pressure to an accumulator. The action of fluid moving to the accumulator reduces the isolated brake pressure at the wheel cylinders. The dump (pressure venting) cycle is limited to very short time periods (milliseconds). The CAB will pulse the dump valve until rear wheel deceleration reaches the desired slip rate programmed into the CAB. The system will switch to normal braking once wheel locking tendencies are no longer present.

DESCRIPTION AND OPERATION (Continued)

RWAL COMPONENT LOCATION

DESCRIPTION

COMPONENT	LOCATION	FUNCTION
RWAL CONTROLLER	Driver side inner fender on a bracket.	Tests, monitors and controls the rear brake system.
HYDRAULIC CONTROL UNIT/ RWAL VALVE	Driver side inner fender on a bracket.	Modulates hydraulic pressure to rear brakes during an RWAL stop.
REAR WHEEL SPEED SENSOR	Top of the rear axle housing.	Sends an AC voltage sinewave to the CAB whose frequency is proportional to vehicle speed.
EXCITER RING	Ring gear inside the differential housing.	Used to pull the magnetic field across the wheel speed sensor's windings.
RED BRAKE WARNING LAMP	Instrument cluster.	Indicator for park brake engagement, hydraulic brake malfunction, or RWAL malfunction.
AMBER ABS WARNING LAMP	Instrument cluster.	Indicator of an RWAL malfunction.
BRAKE WARNING LAMP DIODE	Instrument panel harness near the parking brake switch.	Isolates the park brake switch circuit from the CAB for proper red brake warning lamp operation.
ISOLATION AND DUMP VALVE FUSE	Inside the CAB.	Fail-safe device for unwanted control of the isolation and dump solenoid/valves
ISOLATION AND DUMP SOLENOID/VALVES	Inside the HCU/RWAL valve.	Used to modulation hydraulic pressure to the rear brakes during an RWAL stop.

CONTROLLER REAR WHEEL ANTILOCK BRAKES

DESCRIPTION

The Controller Antilock Brakes (CAB) is a micro-processor which handles testing, monitoring and controlling the ABS brake system operation (Fig. 1). The CAB functions are:

- Perform self-test diagnostics.
- Monitor the RWAL brake system for proper operation.
- Control the RWAL valve solenoids.

NOTE: If the CAB needs to be replaced, the rear axle type and tire revolutions per mile must be programmed into the new CAB. For axle type refer to Group 3 Differential and Driveline. For tire revolutions per mile refer to Group 22 Tire and Wheels. To program the CAB refer to the Chassis Diagnostic Manual.

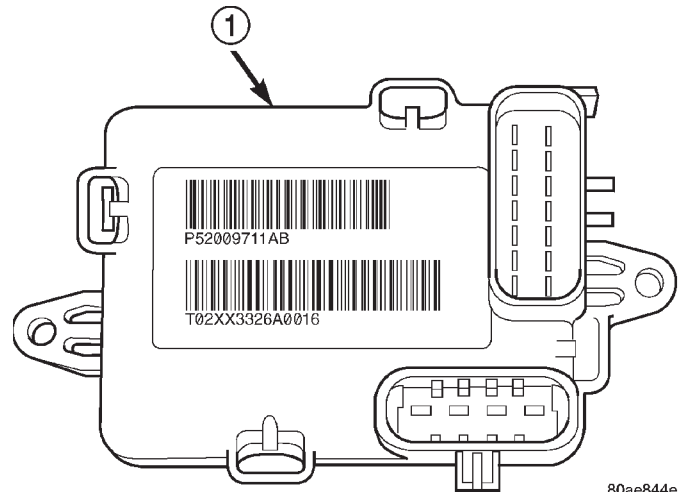

80ae844e

Fig. 1 RWAL CAB

1 – RWAL CAB

DESCRIPTION AND OPERATION (Continued)

OPERATION

SYSTEM SELF-TEST

When the ignition switch is turned-on the micro-processor RAM and ROM are tested. If an error occurs during the test, a DTC will be set into the RAM memory. However it is possible the DTC will not be stored in memory if the error has occurred in the RAM module were the DTC's are stored. Also it is possible a DTC may not be stored if the error has occurred in the ROM which signals the RAM to store the DTC.

CAB INPUTS

The CAB continuously monitors the speed of the differential ring gear by monitoring signals generated by the rear wheel speed sensor. The CAB determines a wheel locking tendency when it recognizes the ring gear is decelerating too rapidly. The CAB monitors the following inputs to determine when a wheel locking tendency may exists:

- Rear Wheel Speed Sensor
- Brake Lamp Switch
- Brake Warning Lamp Switch
- Reset Switch
- 4WD Switch (If equipped)

CAB OUTPUTS

The CAB controls the following outputs for antilock braking and brake warning information:

- RWAL Valve
- ABS Warning Lamp
- Brake Warning Lamp

RWAL VALVE

DESCRIPTION

The valve is located on the drivers side inner fender under the hood. The valve modulates hydraulic pressure to the rear brakes during an RWAL stop.

OPERATION

If the CAB senses that rear wheel speed deceleration is excessive, it will energize an isolation solenoid by providing battery voltage to the solenoid. This prevents a further increase of driver induced brake pressure to the rear wheels. If this initial action is not enough to prevent rear wheel lock-up, the CAB will momentarily energize a dump solenoid (the CAB energizes the dump solenoid by providing battery voltage to the solenoid). This opens the dump valve to vent a small amount of isolated rear brake pressure to an accumulator. The action of fluid moving to the accumulator reduces the isolated brake pressure at the wheel cylinders. The dump (pressure venting) cycle is limited to very short time periods (millisec-

onds). The CAB will pulse the dump valve until rear wheel deceleration matches the desired slip rate programmed into the CAB. The system will switch to normal braking once wheel locking tendencies are no longer present.

A predetermined maximum number of consecutive dump cycles can be performed during any RWAL stop. If excessive dump cycles occur, a DTC will be set and stored in the CAB memory. If during a RWAL stop, the driver releases the brake pedal, the reset switch contacts will open. This signal to the CAB is an indication that pressure has equalized across the RWAL valve. The CAB will then reset the dump cycle counter in anticipation of the next RWAL stop. Additionally, any fluid stored in the accumulator will force its way past the dump valve, back into the hydraulic circuit and return to the master cylinder.

A fuse internal to the CAB, provides a fail-safe device which prevents unwanted control over the isolation and dump solenoids. The fuse is in series with the isolation and dump solenoids output circuits. If the internal fuse is open, the CAB cannot provide voltage to energize either solenoid and RWAL stops are prevented. If the fuse is open, the braking system will operate normally but without antilock control over rear brake pressure.

REAR WHEEL SPEED SENSOR AND EXCITER RING

DESCRIPTION

The rear Wheel Speed Sensor (WSS) is mounted in the rear differential housing (Fig. 2).

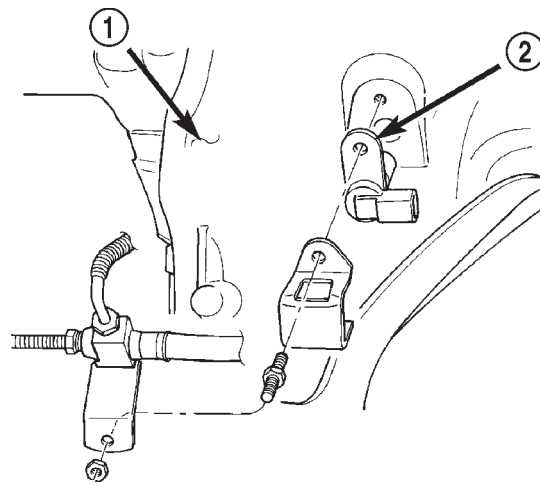

80b6b2a1

Fig. 2 Rear Wheel Speed Sensor Location

- 1 - DIFFERENTIAL HOUSING
- 2 - WHEEL SPEED SENSOR

The exciter ring is press fitted onto the differential carrier next to the final drive ring gear (Fig. 3). For

DESCRIPTION AND OPERATION (Continued)

replacement procedure of the exciter ring, refer to Group 3 Differential and Driveline.

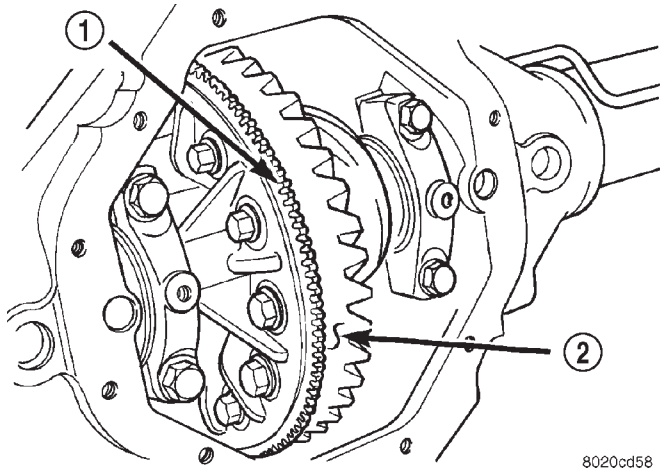

Fig. 3 Exciter Ring Location

- 1 - EXCITER RING
2 - RING GEAR

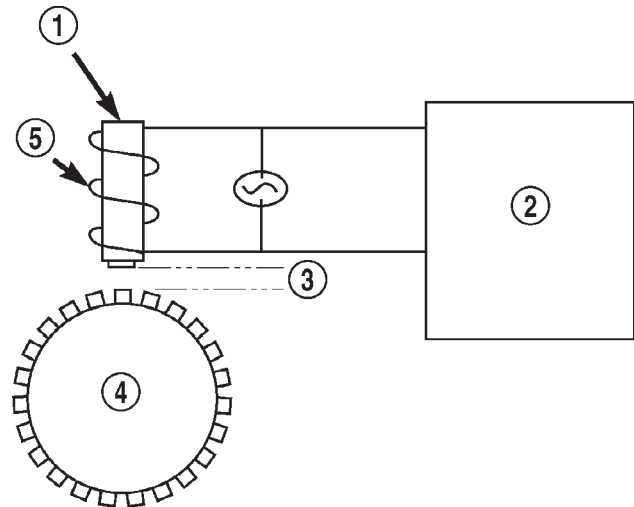

Fig. 4 Operation of the Wheel Speed Sensor

- 1 - MAGNETIC CORE
2 - CAB
3 - AIR GAP
4 - EXCITER RING
5 - COIL

OPERATION

The WSS consists of a magnet surrounded by windings from a single strand of wire. The sensor sends a small AC signal to the CAB. This signal is generated by magnetic induction. The magnetic induction is created when a toothed sensor ring (exciter ring or tone wheel) passes the stationary magnetic WSS.

When the ring gear is rotated, the exciter ring passes the tip of the WSS. As the exciter ring tooth approaches the tip of the WSS, the magnetic lines of force expand, causing the magnetic field to cut across the sensor's windings. This, in turn causes current to flow through the WSS circuit (Fig. 4) in one direction. When the exciter ring tooth moves away from the sensor tip, the magnetic lines of force collapse cutting the winding in the opposite direction. This causes the current to flow in the opposite direction. Every time a tooth of the exciter ring passes the tip of the WSS, an AC signal is generated. Each AC signal (positive to negative signal or sinewave) is interpreted by the CAB. It then compares the frequency of the sinewave to a time value to calculate vehicle speed. The CAB continues to monitor the frequency to determine a deceleration rate that would indicate a possible wheel-locking tendency.

The signal strength of any magnetic induction sensor is directly affected by:

- Magnetic field strength; the stronger the magnetic field, the stronger the signal
- Number of windings in the sensor; more windings provide a stronger signal
- Exciter ring speed; the faster the exciter ring rotates, the stronger the signal will be

- Distance between the exciter ring teeth and WSS; the closer the WSS is to the exciter ring, the stronger the signal will be

The rear WSS is not adjustable. A clearance specification has been established for manufacturing tolerances. If the clearance is not within these specifications, then either the WSS or other components may be damaged. The clearance between the WSS and the exciter ring is 0.005 - 0.050 in.

The assembly plant performs a "Rolls Test" on every vehicle that leaves the assembly plant. One of the test performed is a test of the WSS. To properly test the sensor, the assembly plant connects test equipment to the Data Link Connector (DLC). This connector is located to the right of the steering column and attached to the lower portion of the instrument panel (Fig. 5). The rolls test terminal is spliced to the WSS circuit. The vehicle is then driven on a set of rollers and the WSS output is monitored for proper operation.

BRAKE WARNING LAMPS

DESCRIPTION

The red brake warning lamp and amber ABS warning lamp are located in the instrument cluster. The red brake warning lamp is used to alert the driver of a hydraulic fault or that the parking brake is applied. For the RWAL system, the red brake

DESCRIPTION AND OPERATION (Continued)

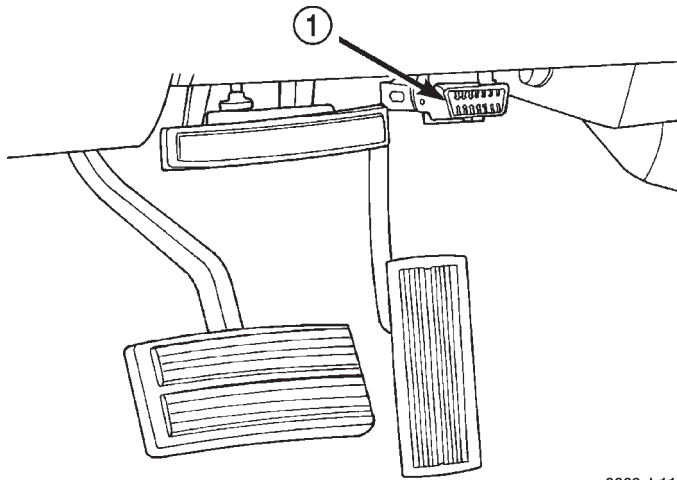

8069cb11

Fig. 5 Data Link Connector - Typical

1 - 16-WAY DATA LINK CONNECTOR

warning lamp also is used to alerts the driver of a problem with the RWAL system.

OPERATION

The red brake warning lamp illuminates when a message is sent over the bus to the cluster to illuminate the bulb. A ground for the bulb is provided when:

- The parking brake is applied and the park brake switch is actuated.
- A hydraulic fault has occurred and the pressure differential switch is actuated.
- A RWAL fault has occurred.

The amber ABS warning lamp is used to alert the driver of an RWAL problem and identify DTCs stored in the CABs memory.

BRAKE LAMP SWITCH

DESCRIPTION

The plunger type brake lamp switch is mounted on a bracket attached to the brake pedal support.

CAUTION: The switch can only be adjusted during initial installation. If the switch is not adjusted properly a new switch must be installed.

OPERATION

The primary function of the switch is to turn on the brake lamps during braking. The switch is also used to send signals to components that must know when the brakes are applied, such as the Powertrain Control Module (PCM), which uses the signal to cancel speed control. The CAB uses the brake switch signal to monitor brake pedal application. When the switch contacts open (brakes applied), the CAB

receives the brake applied signal. The CAB then monitors the RWAL system to anticipate the need for an RWAL stop.

DIAGNOSIS AND TESTING

REAR WHEEL ANTILOCK

Diagnosis of base brake conditions which are mechanical in nature should be performed first. This includes brake noise, lack of power assist, parking brake, or vehicle vibration during normal braking.

The RWAL brake system performs several self-tests every time the ignition switch is turned on and the vehicle is driven. The CAB monitors the system inputs and outputs circuits to verify the system is operating properly. If the CAB senses a malfunction in the system it will set a DTC into memory and trigger the warning lamp.

NOTE: The MDS or DRB III scan tool is used to diagnose the RWAL system. For test procedures refer to the Chassis Diagnostic Manual. For additional information refer to the Antilock brake section in Group 8W.

RWAL SERVICE PRECAUTIONS

The RWAL uses an electronic control module, the CAB. This module is designed to withstand normal current draws associated with vehicle operation. Care must be taken to avoid overloading the CAB circuits. **In testing for open or short circuits, do not ground or apply voltage to any of the circuits unless instructed to do so for a diagnostic procedure.** These circuits should only be tested using a high impedance multi-meter or the DRB tester as described in this section. Power should never be removed or applied to any control module with the ignition in the ON position. Before removing or connecting battery cables, fuses, or connectors, always turn the ignition to the OFF position.

CAUTION: Use only factory wiring harnesses. Do not cut or splice wiring to the brake circuits. The addition of after-market electrical equipment (car phone, radar detector, citizen band radio, trailer lighting, trailer brakes, ect.) on a vehicle equipped with antilock brakes may affect the function of the antilock brake system.

SERVICE PROCEDURES

REAR WHEEL ANTILOCK BRAKE BLEEDING

Use Mopar brake fluid, or an equivalent quality fluid meeting SAE J1703-F and DOT 3 standards only. Use fresh, clean fluid from a sealed container at all times.

Do not pump the brake pedal at any time while bleeding. Air in the system will be compressed into small bubbles that are distributed throughout the hydraulic system. This will make additional bleeding operations necessary.

Do not allow the master cylinder to run out of fluid during bleed operations. An empty cylinder will allow additional air to be drawn into the system. Check the cylinder fluid level frequently and add fluid as needed.

Bleed only one brake component at a time in the following sequence:

- Master Cylinder
- Combination Valve
- Rear Antilock Valve
- Left Rear Wheel
- Right Rear Wheel
- Right Front Wheel
- Left Front Wheel

MANUAL BLEEDING

- (1) Remove reservoir filler caps and fill reservoir.
- (2) If calipers, or wheel cylinders were overhauled, open all caliper and wheel cylinder bleed screws. Then close each bleed screw as fluid starts to drip from it. Top off master cylinder reservoir once more before proceeding.
- (3) Attach one end of bleed hose to bleed screw and insert opposite end in glass container partially filled with brake fluid (Fig. 6). Be sure end of bleed hose is immersed in fluid.
- (4) Open up bleeder, then have a helper press down the brake pedal. Once the pedal is down close the bleeder. Repeat bleeding until fluid stream is clear and free of bubbles. Then move to the next wheel.

PRESSURE BLEEDING

Follow the manufacturers instructions carefully when using pressure equipment. Do not exceed the tank manufacturers pressure recommendations. Generally, a tank pressure of 15-20 psi is sufficient for bleeding.

Fill the bleeder tank with recommended fluid and purge air from the tank lines before bleeding.

Do not pressure bleed without a proper master cylinder adapter. The wrong adapter can lead to leakage, or drawing air back into the system. Use the adapter provided with the equipment or Adapter 6921.

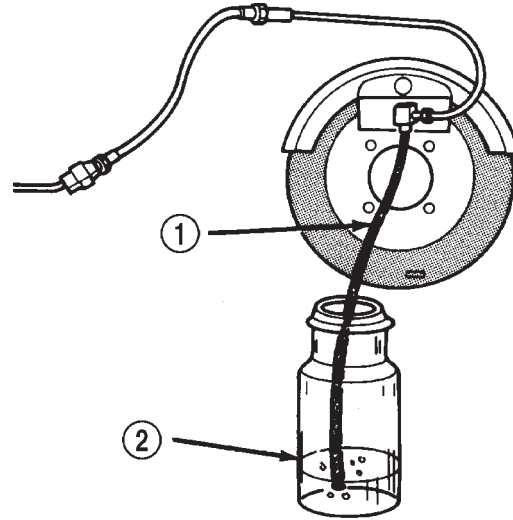

J8905-18

Fig. 6 Bleed Hose Setup

- 1 - BLEED HOSE
2 - FLUID CONTAINER PARTIALLY FILLED WITH FLUID

REMOVAL AND INSTALLATION

CONTROLLER

NOTE: If the CAB needs to be replaced, the rear axle type and tire revolutions per mile must be programmed into the new CAB. For axle type refer to Group 3 Differential and Driveline. For tire revolutions per mile refer to Group 22 Tire and Wheels. To program the CAB refer to the Chassis Diagnostic Manual.

REMOVAL

- (1) Push the CAB harness connector lock to release the lock and remove the connector (Fig. 7) from the controller.
- (2) Remove the RWAL valve harness connector from the controller.
- (3) Remove the controller mounting screws and remove the controller from the mounting bracket (Fig. 7).

INSTALLATION

- (1) Position the controller on the bracket.
- (2) Install the mounting screws and tighten to 6 N·m (53 in. lbs).
- (3) Install the RWAL valve harness connector into the controller.
- (4) Install the CAB harness connector into the controller and push down on the connector lock.

REMOVAL AND INSTALLATION (Continued)

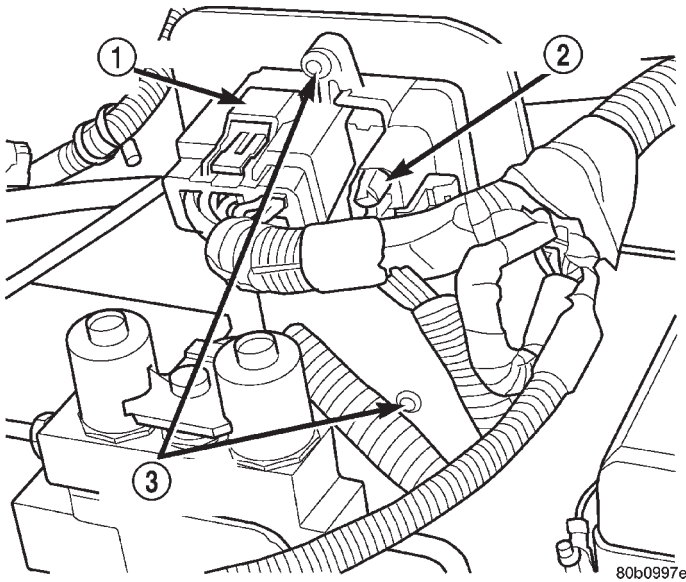

Fig. 7 RWAL Controller

- 1 - CAB CONNECTOR LOCK
- 2 - RWAL CONNECTOR
- 3 - MOUNTING SCREWS

RWAL VALVE

REMOVAL

- (1) Remove RWAL valve harness connector from the RWAL controller.
- (2) Remove the brake lines from the valve.
- (3) Remove the valve mounting bolt (Fig. 8) and remove the valve from the bracket.

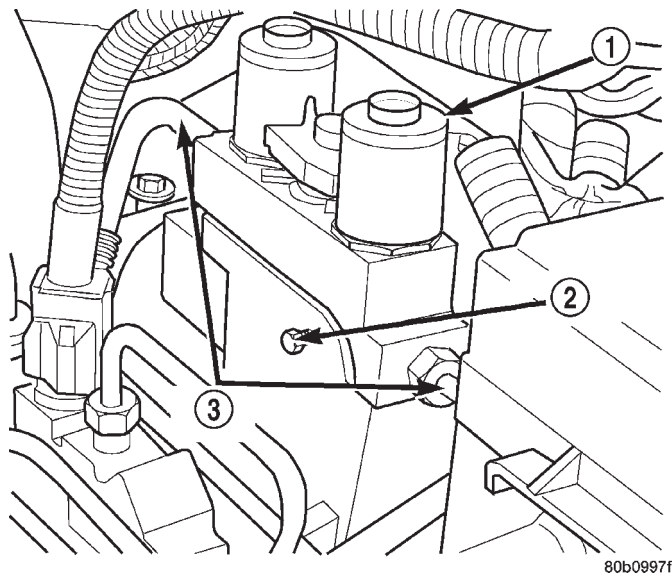

Fig. 8 RWAL Valve

- 1 - RWAL VALVE
- 2 - MOUNTING BOLT
- 3 - BRAKE LINES

INSTALLATION

- (1) Position the valve on the bracket and install the mounting bolt. Tighten the mounting bolt to 20-27 N·m (15-20 ft. lbs.).
- (2) Install the brake lines and tighten to 19 N·m (170 in. lbs.).
- (3) Install the RWAL valve harness connector into the RWAL controller.
- (4) Bleed base brake system.

REAR WHEEL SPEED SENSOR

REMOVAL

- (1) Raise vehicle on hoist.
- (2) Remove brake line mounting nut and remove the brake line from the sensor stud.
- (3) Remove mounting stud from the sensor and shield (Fig. 9).

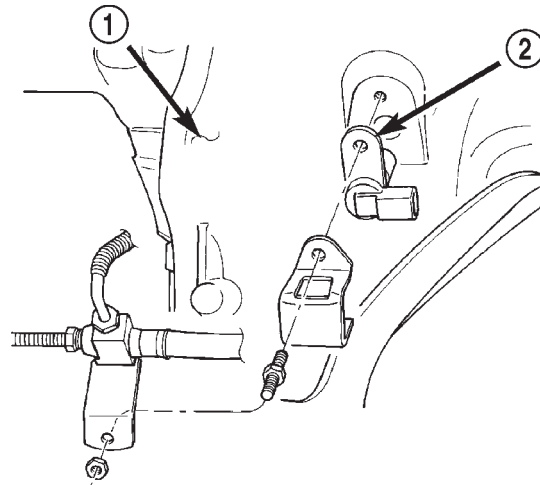

Fig. 9 Rear Speed Sensor Mounting

- 1 - DIFFERENTIAL HOUSING
- 2 - WHEEL SPEED SENSOR

- (4) Remove sensor and shield from differential housing.
- (5) Disconnect sensor wire harness and remove sensor.

INSTALLATION

- (1) Connect harness to sensor. **Be sure seal is securely in place between sensor and wiring connector.**
- (2) Install O-ring on sensor (if removed).
- (3) Insert sensor in differential housing.
- (4) Install sensor shield.
- (5) Install the sensor mounting stud and tighten to 24 N·m (200 in. lbs.).
- (6) Install the brake line on the sensor stud and install the nut.
- (7) Lower vehicle.

REMOVAL AND INSTALLATION (Continued)

EXCITER RING

The exciter ring is mounted on the differential case. If the ring is damaged refer to Group 3 Differential and Driveline for service procedures.

SPECIFICATIONS

TORQUE CHART

DESCRIPTION	TORQUE
Controller	
Mounting Screws	6 N·m (53 in. lbs.)
RWAL Valve	
Mounting Bolt	20-27 N·m (15-20 ft. lbs.)
Brake Line Fittings	19 N·m (170 in. lbs.)
Wheel Speed Sensor	
Mounting Bolt	24 N·m (200 in. lbs.)

FOUR WHEEL ANTILOCK BRAKES

TABLE OF CONTENTS

	page		page
DESCRIPTION AND OPERATION		REMOVAL AND INSTALLATION	
ANTILOCK BRAKE SYSTEM	40	CONTROLLER ANTILOCK BRAKES.....	44
CONTROLLER ANTILOCK BRAKES.....	41	ANTILOCK CONTROL ASSEMBLY.....	44
HYDRAULIC CONTROL UNIT.....	41	FRONT WHEEL SPEED SENSOR - 4x2.....	45
WHEEL SPEED SENSOR.....	42	FRONT WHEEL SPEED SENSOR - 4x4.....	46
ABS WARNING LAMP	43	TONE WHEEL	46
DIAGNOSIS AND TESTING		REAR WHEEL SPEED SENSOR	46
ANTILOCK BRAKES.....	43	EXCITER RING	47
SERVICE PROCEDURES		SPECIFICATIONS	
BLEEDING ABS BRAKE SYSTEM	44	TORQUE CHART.....	47

DESCRIPTION AND OPERATION

ANTILOCK BRAKE SYSTEM

DESCRIPTION

The antilock brake system (ABS) is an electronically operated, all wheel brake control system.

The system is designed to prevent wheel lockup and maintain steering control during periods of high wheel slip when braking. Preventing lockup is accomplished by modulating fluid pressure to the wheel brake units.

The hydraulic system is a three channel design. The front wheel brakes are controlled individually and the rear wheel brakes in tandem (Fig. 1). The ABS electrical system is separate from other electrical circuits in the vehicle. A specially programmed controller antilock brake unit operates the system components.

ABS system major components include:

- Controller Antilock Brakes (CAB)
- Hydraulic Control Unit (HCU)
- Wheel Speed Sensors (WSS)
- ABS Warning Light

OPERATION

Battery voltage is supplied to the CAB ignition terminal when the ignition switch is turned to Run position. The CAB performs a system initialization procedure at this point. Initialization consists of a static and dynamic self check of system electrical components.

The static and dynamic checks occurs at ignition start up. During the dynamic check, the CAB briefly cycles the pump and solenoids to verify operation. An audible noise may be heard during this self check. This noise should be considered normal.

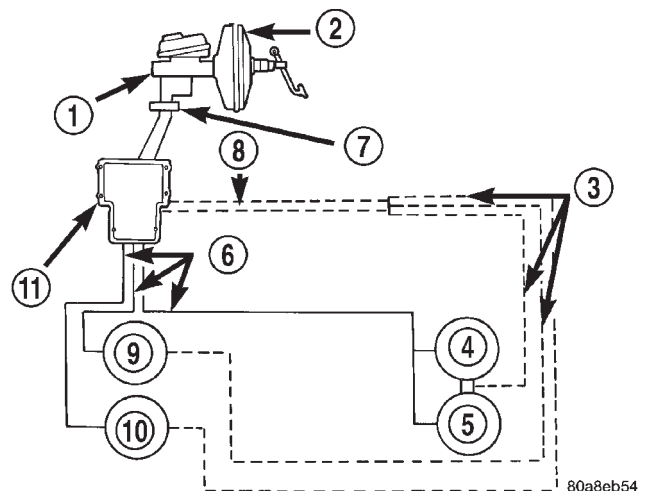

Fig. 1 Antilock Brake System

- 1 - MASTER CYLINDER AND RESERVOIR
- 2 - POWER BRAKE BOOSTER
- 3 - WIRES TO WHEEL SPEED SENSORS
- 4 - RIGHT REAR WHEEL
- 5 - LEFT REAR WHEEL
- 6 - HYDRAULIC BRAKE LINES TO WHEELS
- 7 - COMBINATION VALVE
- 8 - HARNESS
- 9 - RIGHT FRONT WHEEL
- 10 - LEFT FRONT WHEEL
- 11 - CAB/HCU

If an ABS component exhibits a fault during initialization, the CAB illuminates the amber warning light and registers a fault code in the microprocessor memory.

The CAB monitors wheel speed sensor inputs continuously while the vehicle is in motion. However, the CAB will not activate any ABS components as long as sensor inputs indicate normal braking.

DESCRIPTION AND OPERATION (Continued)

During normal braking, the master cylinder, power booster and wheel brake units all function as they would in a vehicle without ABS. The HCU components are not activated.

The purpose of the antilock system is to prevent wheel lockup during periods of high wheel slip. Preventing lockup helps maintain vehicle braking action and steering control.

The antilock CAB activates the system whenever sensor signals indicate periods of high wheel slip. High wheel slip can be described as the point where wheel rotation begins approaching 20 to 30 percent of actual vehicle speed during braking. Periods of high wheel slip occur when brake stops involve high pedal pressure and rate of vehicle deceleration.

The antilock system prevents lockup during high slip conditions by modulating fluid apply pressure to the wheel brake units.

Brake fluid apply pressure is modulated according to wheel speed, degree of slip and rate of deceleration. Sensors at each front wheel convert wheel speed into electrical signals. These signals are transmitted to the CAB for processing and determination of wheel slip and deceleration rate.

The ABS system has three fluid pressure control channels. The front brakes are controlled separately and the rear brakes in tandem. A speed sensor input signal indicating a high slip condition activates the CAB antilock program.

Two solenoid valves are used in each antilock control channel. The valves are all located within the HCU valve body and work in pairs to either increase, hold, or decrease apply pressure as needed in the individual control channels.

The solenoid valves are not static during antilock braking. They are cycled continuously to modulate pressure. Solenoid cycle time in antilock mode can be measured in milliseconds.

CONTROLLER ANTILOCK BRAKES

DESCRIPTION

The CAB is mounted on the top of the hydraulic control unit (Fig. 2). The CAB operates the ABS system and is separate from other vehicle electrical circuits. CAB voltage source is through the ignition switch in the RUN position.

OPERATION

The CAB contains dual microprocessors. A logic block in each microprocessor receives identical sensor signals. These signals are processed and compared simultaneously.

The CAB contains a self check program that illuminates the ABS warning light when a system fault

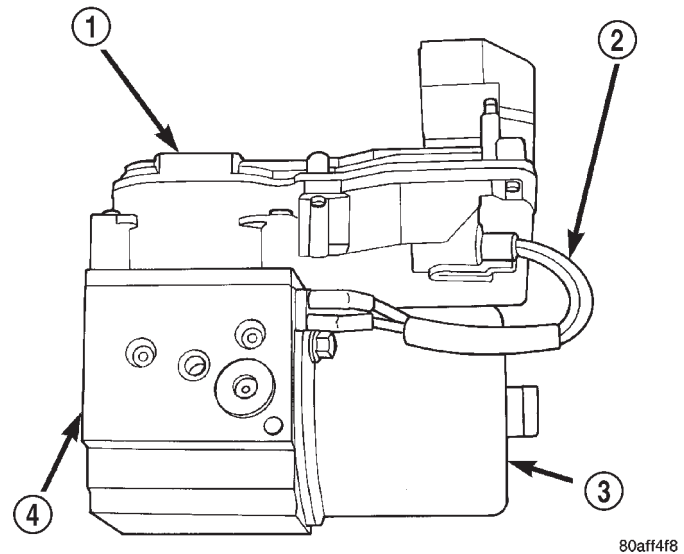

Fig. 2 CAB/HCU

- 1 - CAB
- 2 - PUMP WIRING
- 3 - PUMP MOTOR
- 4 - HCU

is detected. Faults are stored in a diagnostic program memory and are accessible with the DRB scan tool.

ABS faults remain in memory until cleared, or until after the vehicle is started approximately 50 times. Stored faults are **not** erased if the battery is disconnected.

NOTE: If the CAB needs to be replaced, the rear axle type and tire revolutions per mile must be programmed into the new CAB. For axle type refer to Group 3 Differential and Driveline. For tire revolutions per mile refer to Group 22 Tire and Wheels. To program the CAB refer to the Chassis Diagnostic Manual.

HYDRAULIC CONTROL UNIT

DESCRIPTION

The hydraulic control unit (HCU) consists of a valve body, pump, two accumulators and a motor (Fig. 2). The assembly is mounted on the driverside inner fender under the hood.

OPERATION

The pump, motor, and accumulators are combined into an assembly attached to the valve body. The accumulators store the extra fluid which had to be dumped from the brakes. This is done to prevent the wheels from locking up. The pump provides the fluid volume needed and is operated by a DC type motor. The motor is controlled by the CAB.

DESCRIPTION AND OPERATION (Continued)

During normal braking, the HCU solenoid valves and pump are not activated. The master cylinder and power booster operate the same as a vehicle without an ABS brake system.

The valve body contains the solenoid valves. The valves modulate brake pressure during antilock braking and are controlled by the CAB.

The HCU provides three channel pressure control to the front and rear brakes. One channel controls the rear wheel brakes in tandem. The two remaining channels control the front wheel brakes individually.

During antilock braking, the solenoid valves are opened and closed as needed. The valves are not static. They are cycled rapidly and continuously to modulate pressure and control wheel slip and deceleration.

During antilock braking, solenoid valve pressure modulation occurs in three stages, pressure decrease, pressure hold, and pressure increase. The valves are all contained in the valve body portion of the HCU.

PRESSURE DECREASE

The inlet valve is closed and the outlet valve is opened during the pressure decrease cycle.

A pressure decrease cycle is initiated when speed sensor signals indicate high wheel slip at one or more wheels. At this point, the CAB closes the inlet to prevent the driver from further increasing the brake pressure and locking the brakes. The CAB then opens the outlet valve, which also opens the return circuit to the accumulators. Fluid pressure is allowed to bleed off (decrease) as needed to prevent wheel lock.

Once the period of high wheel slip has ended, the CAB closes the outlet valve and begins a pressure increase or hold cycle as needed.

PRESSURE HOLD

Both solenoid valves are closed in the pressure hold cycle. Fluid apply pressure in the control channel is maintained at a constant rate. The CAB maintains the hold cycle until sensor inputs indicate a pressure change is necessary.

PRESSURE INCREASE

The inlet valve is open and the outlet valve is closed during the pressure increase cycle. The pressure increase cycle is used to counteract unequal wheel speeds. This cycle controls re-application of fluid apply pressure due to changing road surfaces or wheel speed.

WHEEL SPEED SENSOR

DESCRIPTION

The ABS brake system uses 3 wheel speed sensors. A sensor is mounted to each front steering knuckles. The third sensor is mounted on top of the rear axle differential housing.

OPERATION

The WSS consists of a magnet surrounded by windings from a single strand of wire. The sensor sends a small AC signal to the CAB. This signal is generated by magnetic induction. The magnetic induction is created when a toothed sensor ring (exciter ring or tone wheel) passes the stationary magnetic WSS.

When the ring gear is rotated, the exciter ring passes the tip of the WSS. As the exciter ring tooth approaches the tip of the WSS, the magnetic lines of force expand, causing the magnetic field to cut across the sensor's windings. This, in turn causes current to flow through the WSS circuit (Fig. 3) in one direction. When the exciter ring tooth moves away from the sensor tip, the magnetic lines of force collapse cutting the winding in the opposite direction. This causes the current to flow in the opposite direction. Every time a tooth of the exciter ring passes the tip of the WSS, an AC signal is generated. Each AC signal (positive to negative signal or sinewave) is interpreted by the CAB. It then compares the frequency of the sinewave to a time value to calculate vehicle speed. The CAB continues to monitor the frequency to determine a deceleration rate that would indicate a possible wheel-locking tendency.

The signal strength of any magnetic induction sensor is directly affected by:

- Magnetic field strength; the stronger the magnetic field, the stronger the signal
- Number of windings in the sensor; more windings provide a stronger signal
- Exciter ring speed; the faster the exciter ring/tone wheel rotates, the stronger the signal will be
- Distance between the exciter ring teeth and WSS; the closer the WSS is to the exciter ring/tone wheel, the stronger the signal will be

The rear WSS is not adjustable. A clearance specification has been established for manufacturing tolerances. If the clearance is not within these specifications, then either the WSS or other components may be damaged. The clearance between the WSS and the exciter ring is 0.005 – 0.050 in.

DESCRIPTION AND OPERATION (Continued)

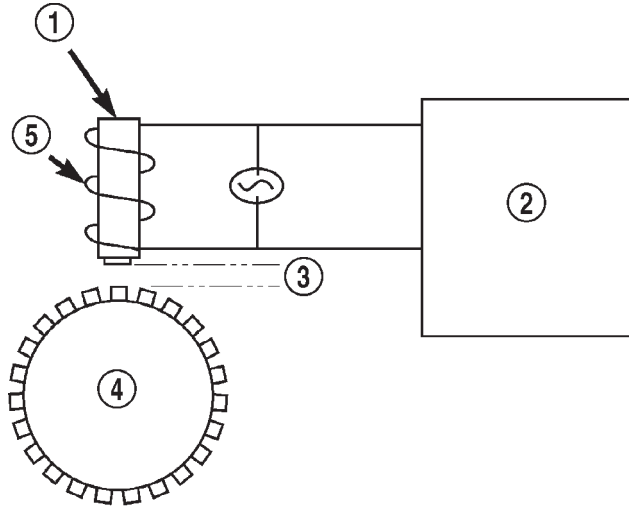

Fig. 3 Operation of the Wheel Speed Sensor

- 1 - MAGNETIC CORE
- 2 - CAB
- 3 - AIR GAP
- 4 - EXCITER RING
- 5 - COIL

8020cd59

The assembly plant performs a “Rolls Test” on every vehicle that leaves the assembly plant. One of the test performed is a test of the WSS. To properly test the sensor, the assembly plant connects test equipment to the Data Link Connector (DLC). This connector is located to the right of the steering column and attached to the lower portion of the instrument panel (Fig. 4). The rolls test terminal is spliced to the WSS circuit. The vehicle is then driven on a set of rollers and the WSS output is monitored for proper operation.

ABS WARNING LAMP

DESCRIPTION

The amber ABS warning lamp and red warning lamp are located in the instrument cluster. The amber ABS warning lamp illuminates at start-up to perform a self check. The lamp goes out when the self check program determines the system is operating normal. The red brake warning lamp is used to alert the driver of a hydraulic fault or that the parking brake is applied.

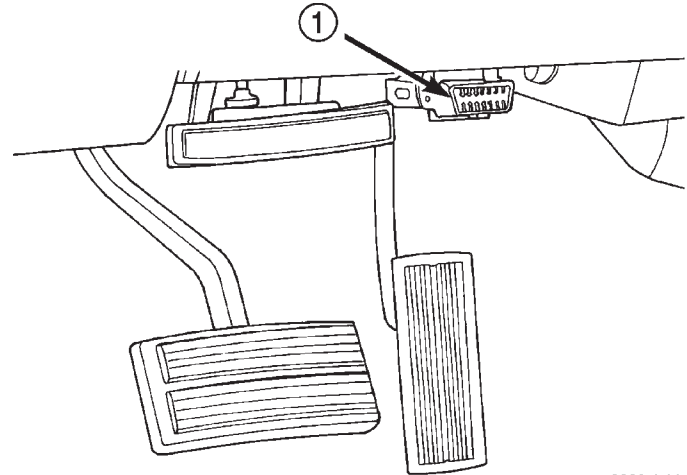

8069cb11

Fig. 4 Data Link Connector - Typical

1 - 16-WAY DATA LINK CONNECTOR

OPERATION

If an ABS component exhibits a fault the CAB will illuminate the ABS warning lamp and register a trouble code in the microprocessor. The lamp is controlled by the CAB. The CAB controls the lamp sending a message to the instrument cluster.

If red warning lamp is illuminate with the amber warning lamp, this may indicate a electronic brake distribution fault.

The red warning lamp will illuminate if an ABS component exhibits a fault and the amber lamp is burned out.

DIAGNOSIS AND TESTING

ANTILOCK BRAKES

The ABS brake system performs several self-tests every time the ignition switch is turned on and the vehicle is driven. The CAB monitors the systems input and output circuits to verify the system is operating correctly. If the on board diagnostic system senses that a circuit is malfunctioning the system will set a trouble code in its memory.

NOTE: An audible noise may be heard during the self-test. This noise should be considered normal.

NOTE: The MDS or DRB III scan tool is used to diagnose the ABS system. For additional information refer to the Antilock Brake section in Group 8W. For test procedures refer to the Chassis Diagnostic Manual.

SERVICE PROCEDURES

BLEEDING ABS BRAKE SYSTEM

ABS system bleeding requires conventional bleeding methods plus use of the DRB scan tool. The procedure involves performing a base brake bleeding, followed by use of the scan tool to cycle and bleed the HCU pump and solenoids. A second base brake bleeding procedure is then required to remove any air remaining in the system.

(1) Perform base brake bleeding. Refer to base brake section for procedure.

(2) Connect scan tool to the Data Link Connector.

(3) Select ANTILOCK BRAKES, followed by MISCELLANEOUS, then BLEED BRAKES. Follow the instructions displayed. When scan tool displays TEST COMPLETE, disconnect scan tool and proceed.

(4) Perform base brake bleeding a second time. Refer to base brake section for procedure.

(5) Top off master cylinder fluid level and verify proper brake operation before moving vehicle.

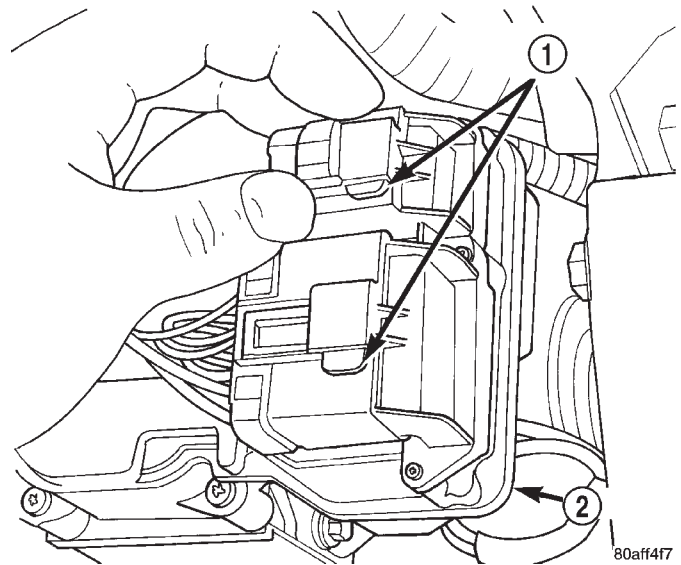

Fig. 5 Harness Connector Locks

- 1 - CONNECTOR LOCK
2 - CAB

REMOVAL AND INSTALLATION

CONTROLLER ANTILOCK BRAKES

NOTE: If the CAB needs to be replaced, the rear axle type and tire revolutions per mile must be programmed into the new CAB. For axle type refer to Group 3 Differential and Driveline. For tire revolutions per mile refer to Group 22 Tire and Wheels. To program the CAB refer to the Chassis Diagnostic Manual.

REMOVAL

(1) Disconnect battery negative cable.

(2) Push the harness connector locks to release the locks, (Fig. 5) then remove the connectors from the CAB.

(3) Disconnect the pump motor connector (Fig. 6).

(4) Remove screws attaching CAB to the HCU (Fig. 7).

(5) Remove the CAB.

INSTALLATION

(1) Place the CAB onto the HCU.

NOTE: Insure the CAB seal is in position before installation.

(2) Install the mounting screws and tighten to 4-4.7 N·m (36-42 in. lbs.).

(3) Connect the pump motor harness.

(4) Connect the harnesses to the CAB and lock the connectors.

(5) Connect battery.

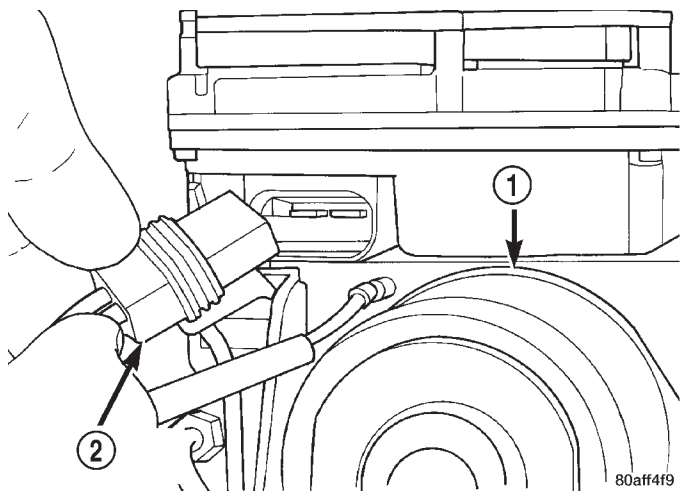

Fig. 6 Pump Motor Connector

- 1 - PUMP MOTOR
2 - PUMP CONNECTOR

ANTILOCK CONTROL ASSEMBLY

NOTE: If the antilock control assembly needs to be replaced, the rear axle type and tire revolutions per mile must be programmed into the new CAB. For axle type refer to Group 3 Differential and Driveline. For tire revolutions per mile refer to Group 22 Tire and Wheels. To program the CAB refer to the Chassis Diagnostic Manual.

REMOVAL AND INSTALLATION (Continued)

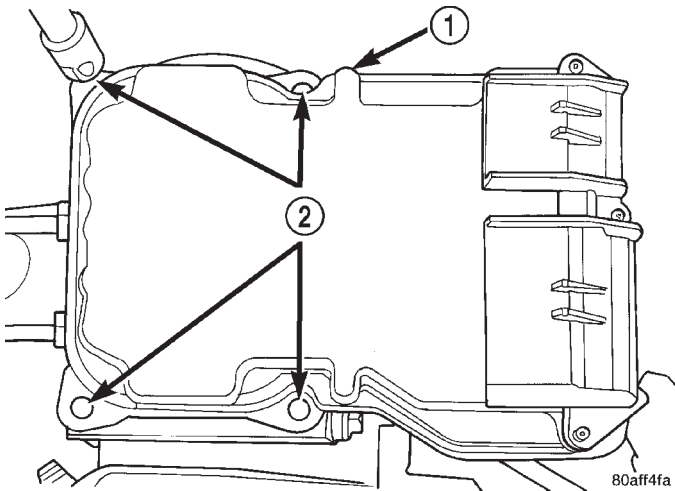

Fig. 7 Controller Mounting Screws

- 1 - CAB
- 2 - MOUNTING LOCATIONS

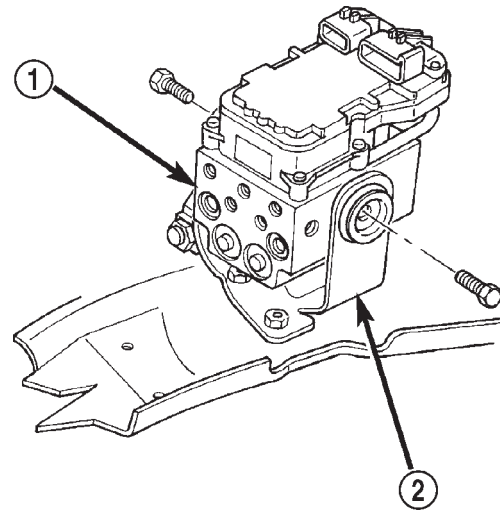

Fig. 9 Mounting Bracket

- 1 - ANTILOCK CONTROL ASSEMBLY
- 2 - MOUNTING BRACKET

REMOVAL

- (1) Disconnect battery negative cable.
- (2) Remove the brake lines from HCU (Fig. 8).
- (3) Push the harness connector locks to release the locks, (Fig. 5) then remove the connectors from the CAB.
- (4) Remove the nuts which attaches the assembly to the mounting bracket (Fig. 9).
- (5) Remove the assembly from the vehicle.

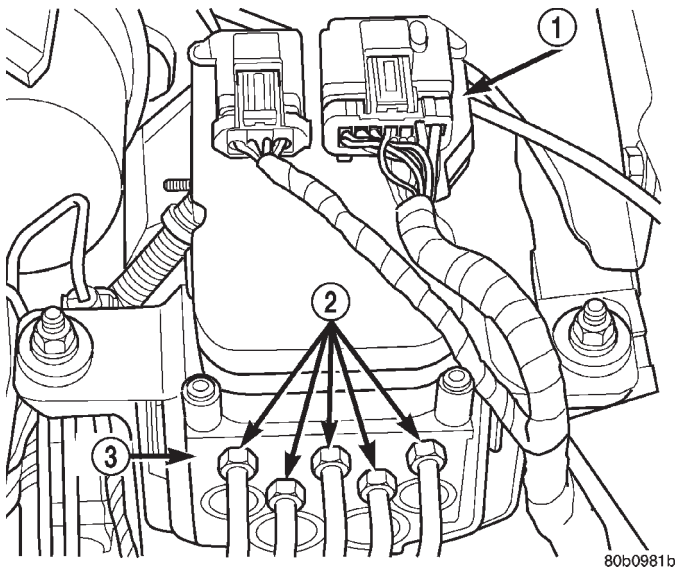

Fig. 8 HCU Brake Lines

- 1 - CAB
- 2 - BRAKE LINES
- 3 - HCU

INSTALLATION

- (1) Install the antilock assembly into the bracket and tighten bolts to 14-15 N·m (10-12 ft. lbs.).
- (2) Connect the CAB harnesses.
- (3) Connect the brake lines to the HCU. Tighten brake line fittings to 19 N·m (170 in. lbs.).
- (4) Connect battery.
- (5) Bleed brake system.

FRONT WHEEL SPEED SENSOR - 4x2

CAUTION: Special bolts are used to attach the front sensor. The bolts have a special shoulder, thread length and surface treatment. If the original bolts must be replaced, use only factory replacement part. Do not use substitute bolts under any circumstances.

REMOVAL

- (1) Raise and support vehicle.
- (2) Remove bolt attaching sensor to the steering knuckle (Fig. 10).
- (3) Remove clamps securing sensor wire to control arm and inner fender panel.
- (4) In engine compartment, disconnect sensor wire from harness and remove sensor.

INSTALLATION

- (1) Position sensor in the knuckle and install sensor attaching bolts. Tighten bolts to 21 N·m (190 in. lbs.).

REMOVAL AND INSTALLATION (Continued)

(2) Secure sensor wire retaining clamps to control arm and fender panel.

(3) In engine compartment, connect sensor wire to harness connector. Make sure wire is routed away from hot or rotating underhood components.

(4) Turn steering wheel back and forth to verify that wire is clear of steering and suspension components.

(5) Remove supports and lower vehicle.

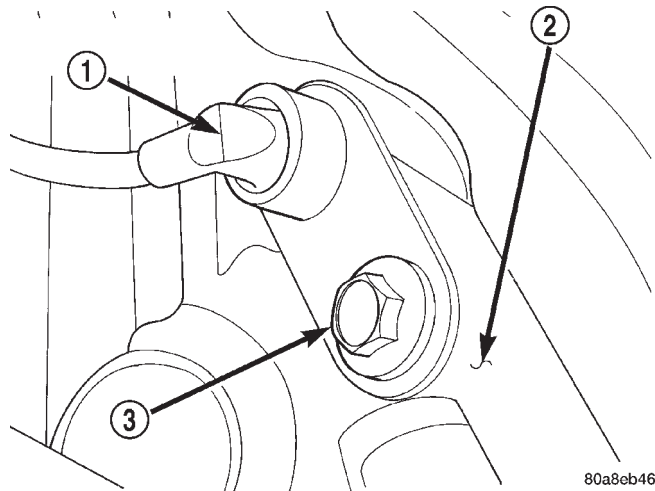

Fig. 10 Front Wheel Speed Sensor - 4x2

- 1 - WHEEL SPEED SENSOR
- 2 - KNUCKLE
- 3 - MOUNTING BOLT

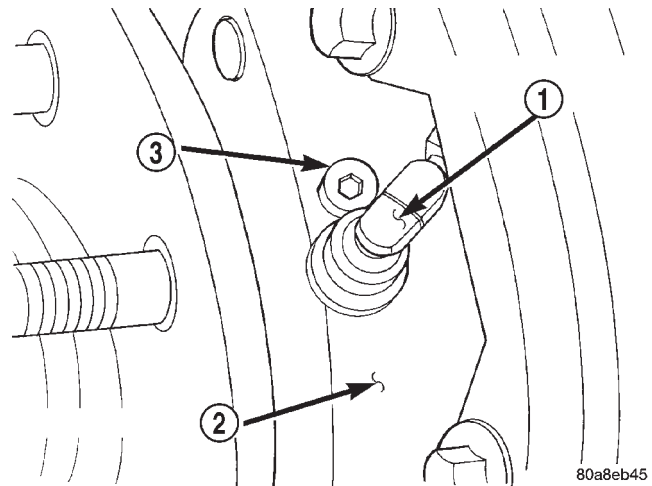

Fig. 11 Front Wheel Speed Sensor - 4x4

- 1 - WHEEL SPEED SENSOR
- 2 - HUB/BEARING
- 3 - MOUNTING BOLTS

FRONT WHEEL SPEED SENSOR - 4x4

CAUTION: Special bolts are used to attach the front sensor. The bolts have a special shoulder, thread length and surface treatment. If the original bolts must be replaced, use only factory replacement bolts. Do not use substitute bolt under any circumstances.

REMOVAL

- (1) Raise and support vehicle.
- (2) Remove wheel and tire assembly.
- (3) Remove brake caliper and rotor.
- (4) Remove bolts attaching sensor to hub/bearing (Fig. 11).
- (5) Remove clamps securing sensor wire to control arm and inner fender panel.
- (6) In engine compartment, disconnect sensor wire and remove sensor.

INSTALLATION

- (1) Guide sensor wire around upper control arm.
- (2) Position sensor on hub/bearing and install attaching bolts. Tighten bolt to 18-25 N·m (160-220 in. lbs.).

(3) Secure sensor wire retaining clamps to control arm and fender panel with original hardware.

(4) In engine compartment, connect sensor wire to harness connector. Insure wire is routed away from hot or rotating underhood components.

(5) Install brake rotor and caliper.

(6) Install wheel and tire assembly.

(7) Turn steering wheel back and forth to verify that wire is clear of steering and suspension components.

(8) Remove supports and lower vehicle.

TONE WHEEL

The tone wheel for the front speed sensor is located on the hub/bearing on 2-wheel drive models (Fig. 12). On 4-wheel drive models, the tone wheel is located in the hub/bearing housing.

The tone wheel is not a serviceable component. To replace the tone wheel the hub/bearing must be replaced. Refer to Group 2 Suspension for the service procedure.

REAR WHEEL SPEED SENSOR

REMOVAL

- (1) Raise vehicle on hoist.
- (2) Remove brake line mounting nut and remove the brake line from the sensor stud.
- (3) Remove mounting stud from the sensor and shield (Fig. 13).
- (4) Remove sensor and shield from differential housing.
- (5) Disconnect sensor wire harness and remove sensor.

REMOVAL AND INSTALLATION (Continued)

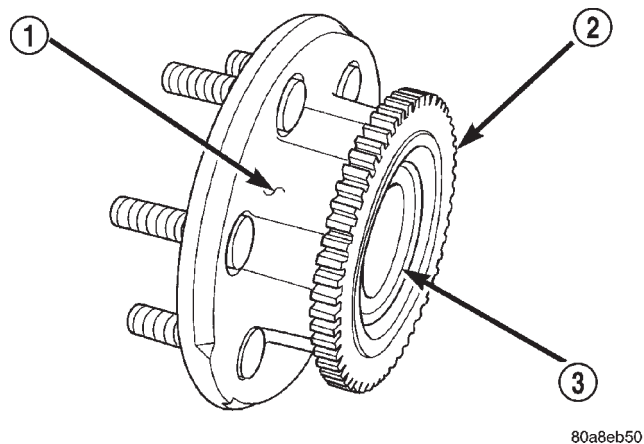

80a8eb50

Fig. 12 Tone Wheel 4x2

- 1 - HUB
- 2 - TONE WHEEL
- 3 - BEARING

- (2) Install O-ring on sensor (if removed).
- (3) Insert sensor in differential housing.
- (4) Install sensor shield.
- (5) Install the sensor mounting stud and tighten to 24 N·m (200 in. lbs.).
- (6) Install the brake line on the sensor stud and install the nut.
- (7) Lower vehicle.

EXCITER RING

The exciter ring is mounted on the differential case. If the ring is damaged refer to Group 3 Differential and Driveline for service procedures.

SPECIFICATIONS

TORQUE CHART

DESCRIPTION	TORQUE
ABS Assembly	
Bracket bolts	14-15 N·m (10-12 ft. lbs.)
Mounting Nuts	12 N·m (102 in. lbs.)
CAB Screws	4-4.7 N·m (36-42 in. lbs.)
Brake Line Fittings	19 N·m (170 in. lbs.)
Wheel Speed Sensors	
Front Sensor Bolt	21 N·m (190 in. lbs.)
Rear Sensor Bolt	22.5 N·m (200 in. lbs.)

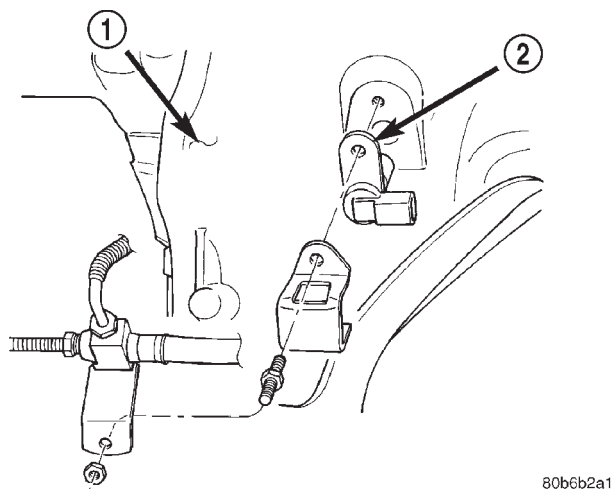

80b6b2a1

Fig. 13 Rear Speed Sensor Mounting

- 1 - DIFFERENTIAL HOUSING
- 2 - WHEEL SPEED SENSOR

INSTALLATION

- (1) Connect harness to sensor. **Be sure seal is securely in place between sensor and wiring connector.**

